

JOB: \_\_\_\_\_

REPRESENTATIVE: \_\_\_\_\_

ENGINEER: \_\_\_\_\_

CONTRACTOR: \_\_\_\_\_

## PRODUCT DATA

ITEM NO. \_\_\_\_\_ MODEL NO. \_\_\_\_\_

MODE \_\_\_\_\_ MODE SETTING \_\_\_\_\_

GPM \_\_\_\_\_ HEAD/FT \_\_\_\_\_

NSF 61 & 372 CERTIFIED YES NO VOLTAGE \_\_\_\_\_

## APPLICATIONS

### DUCTILE IRON MODEL

Closed loop, pressurized Heating and Chilled Water HVAC Systems

### STAINLESS STEEL MODEL

Potable water systems (DHW recirculation, pressure boosting)

## STANDARDS, PROTECTION & FLANGE TYPE

Insulation Class H

Enclosure: Class 2, IP44

Integrated Motor Protection (electronically protected)

Continuous Duty

UL778, 1004-1, 508C

CAN/CSA22.2 #108, #100, #107.1

EMC (89/366EEC): EN 61000

LDV (73/23/EC): EN 60335-1, EN 60335-2-51

Machine Safety (98/37/EC): EN ISO 12100

Standard 125# ANSI Flanges

Stainless Steel Version: NSF/ANSI 61 & 372 Commercial Hot



Stainless Steel Model

## DIMENSIONS

FLANGE SIZE	DIMENSIONS						WEIGHT LBS.	
	A	B	C	D	E	F	CI	SS
3"	14.2 (360)	18.2 (462)	14.5 (369)	10.7 (273)	7.9 (200)	10 (255)	66 (30)	72 (33)

English dimensions are in inches. Metric dimensions are in millimeters. Metric data is presented in ( ). Do not use for construction purposes unless certified.

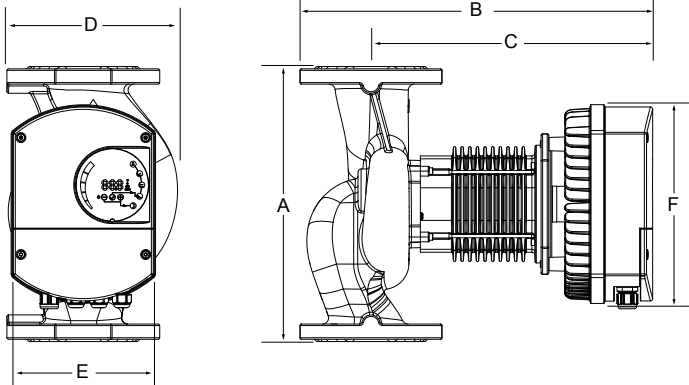

## SPECIFICATIONS

MAX SHUT-OFF HEAD	62 feet
MAX. FLOW	320 USGPM
MAX. OPERATING PRESSURE	175 PSI (12 bar)
WATER TEMPERATURE RANGE	14 to 230°F (-10 to 110°C)
AMBIENT TEMPERATURE RANGE	32 to 104°F (0 to 40°C)
AMBIENT HUMIDITY	Less than 95% RH

## ELECTRICAL SPECIFICATIONS

VOLTAGE (ALL SINGLE PHASE)	200-240
POWER CONSUMPTION (HP)	2.1 HP
POWER CONSUMPTION (W)	1550 W
CURRENT LIMIT	8
24 VOLT SUPPLY OUTLET	Max current up to 100mA, Output Voltage +/- 20% of 24 Volts, Output Ripple under 1 Volt
RELAY OUTLET	230 Vac, 3A, AC1 Potential Free Changeover Contact
NUMBER OF RELAY OUTPUTS	1
ANALOG INPUTS	Max Input Voltage 32Vdc, 2 Inputs, 1 output
ETHERNET	RJ-45 Connector, Http server and FTP Client server

## MATERIALS OF CONSTRUCTION

CASING		IMPELLER	SHAFT	BEARINGS
HVAC MODEL	DHW MODEL			
Cast Iron, Cataphoresis Coated	304 Stainless Steel	PES GF-30	ANSI 420	Carbon SleeveType

## MINIMUM STATIC INLET PRESSURE

at pump suction port (PSIA / bar) to avoid cavitation at fluid temperatures

FLUID TEMPERATURES	PSIA / bar
112°F (50°C)	4.36 / 0.3
176°F (80°C)	14.5 / 1.0
230°F (110°C)	23.2 / 1.6

## OPERATING MODES

- activeADAPT®
- Proportional Pressure
- Constant Pressure
- Constant Speed
- Setback
- BACnet
- ModBus
- 0-10Vdc
- PWM
- Twin Pump Mode

# PERFORMANCE CURVE - VR30H

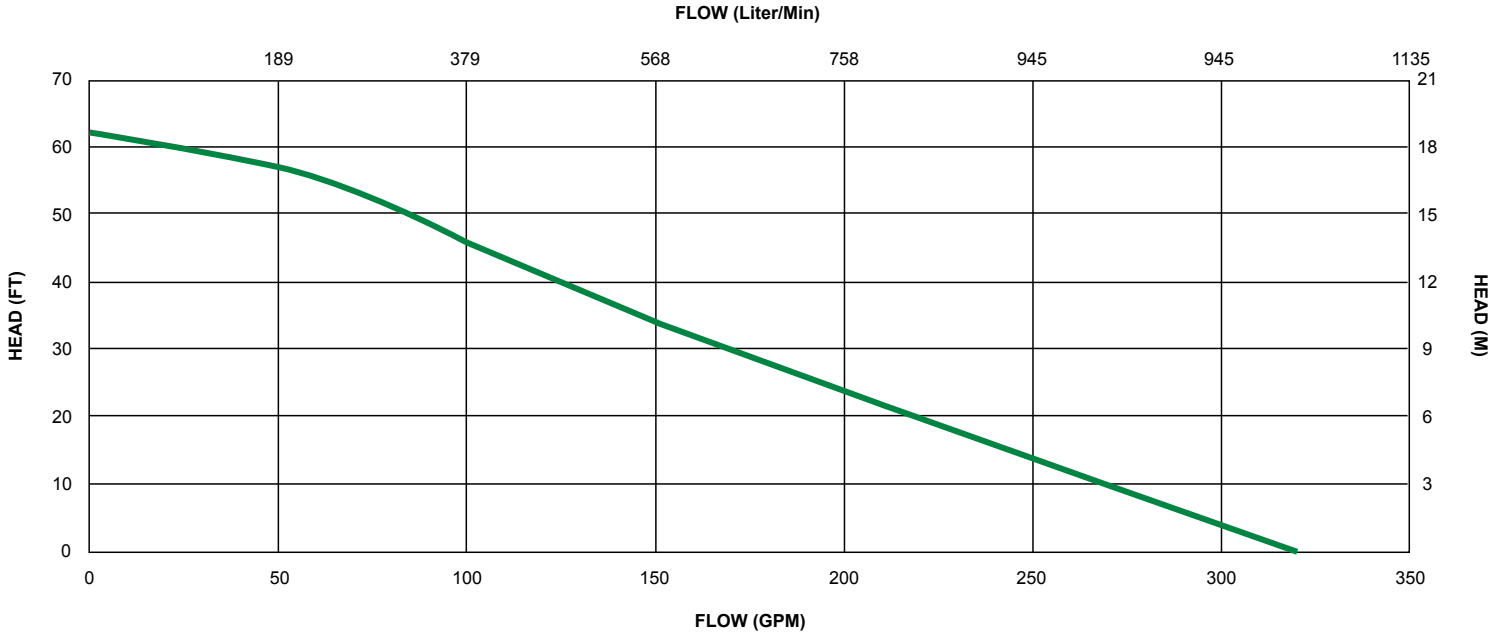

## COMMENTS