

SUPERSEDES: September 1, 2008

EFFECTIVE: December 10, 2015

JOB \_\_\_\_\_ ENGINEER \_\_\_\_\_ CONTRACTOR \_\_\_\_\_ REP. \_\_\_\_\_

ITEM	QUANTITY	MODEL NO.	SIZE

### DIMENSIONS

Model Number	Size	Connection	A	B (Class 125*)	B (Class 250*)	C	D	E	F	C <sub>v</sub>	Weight (125#)	Weight (250#)
MPV 015-4	1½ (38.1) NPT	Threaded	8.00 (203)	1.44 (037)	1.44 (037)	4.70 (119)	2.39 (061)	5.64 (143)	1.3 (33.0)	69	12 (5.5)	12 (5.5)
MPV 020-4	2 (50.8) NPT	Threaded	8.00 (203)	1.44 (037)	1.44 (037)	4.70 (119)	2.39 (061)	5.64 (143)	1.3 (33.0)	77	12 (5.5)	12 (5.5)
MPV 025-4	2½ (63.5) NPT	Threaded	10.63 (270)	1.93 (049)	1.93 (049)	4.97 (126)	3.50 (089)	7.30 (185)	1.6 (40.6)	122	32 (15)	32 (15)
MPV 030-4*	3 (76.2)	Flanged	11.75 (298)	3.75 (095)	4.13 (105)	6.15 (156)	3.90 (099)	7.85 (199)	1.8 (45.7)	209	38 (17)	46 (21)
MPV 040-4*	4 (101.6)	Flanged	13.75 (349)	4.50 (114)	4.50 (114)	8.51 (216)	4.18 (106)	9.63 (245)	2.1 (53.3)	357	67 (30)	84 (38)
MPV 050-4*	5 (127.0)	Flanged	17.63 (448)	5.00 (127)	5.50 (140)	11.26 (286)	5.25 (133)	12.28 (312)	2.4 (61.0)	459	105 (48)	126 (57)
MPV 060-4*	6 (152.4)	Flanged	20.35 (517)	5.50 (140)	6.25 (159)	11.28 (287)	6.07 (154)	14.23 (361)	2.7 (68.6)	701	134 (61)	176 (80)
MPV 080-4*	8 (203.2)	Flanged	25.88 (657)	6.75 (171)	7.50 (191)	13.58 (345)	6.75 (171)	19.13 (486)	3.9 (99.1)	1200	293 (133)	341 (155)
MPV 100-4*	10 (254.0)	Flanged	30.00 (762)	8.00 (203)	8.75 (222)	15.82 (402)	8.81 (224)	21.20 (538)	4.4 (111.8)	1826	466 (212)	536 (243)
MPV 120-4*	12 (304.8)	Flanged	36.70 (932)	9.50 (241)	10.25 (260)	17.54 (446)	9.98 (253)	26.64 (677)	4.9 (124.5)	2430	724 (329)	811 (368)
MPV 140-4*	14 (355.6)	Flanged	41.56 (1056)	10.50 (267)	11.50 (292)	22.80 (579)	12.09 (307)	29.47 (749)	5.4 (137.2)	3147	1105 (502)	1182 (537)

NOTE: Dimensions are in inches. Metric dimensions are in millimeters and are in parentheses ( ). Weights are in lb (kg).

'F' is the distance required to replace packing under pressure. 'A,C,D,E,F' applies to Class 250\* flanged units also.

\* Append 'A' for Class 250\* working pressure flanged units (e.g. Model Number MPV 030-4A).

### FEATURES

- Horizontal or Vertical Installation
- Field Convertible to a Right Angle Valve
- Stem Seal Packing (replaceable under pressure)
- Bronze Fitted Construction
- Memory Indicator, Pointer and Scale
- Shrader Valve Metering Connections
- "O" Ring Sealed Valve Body
- Replaceable "Soft Seal"
- Low Pressure Drop (equal to or better than any comparable valve on the market today)

- Five (5) Valves in One:
  - Shut Off Valve
  - Flow Control Valve (globe style)
  - Non Slam Check Valve
  - Flow Metering Valve
  - Straight Pattern Valve Convertible to a Right Angle Pattern Valve
- Available with Class 125\* flanges or Class 250\* flanges. Consult pressure/temperature chart on page 2 for operating limitations. (Flanged units are raised faced design.)
- Available with Flanged or Grooved End Connections

### MATERIALS OF CONSTRUCTION

- Body - Ductile Iron
- Spring - Stainless Steel (302)
- Gland - Bronze
- Stem Packing - Teflon Impregnated Aramid Fiber (asbestos free)
- Stem - Bronze/Stainless Steel (416)
- Seat - EPDM
- Seat Disc - Stainless Steel (304)
- Body O-Ring - EPDM

(All sizes available with optional DIN flanges. Consult Factory for details.)

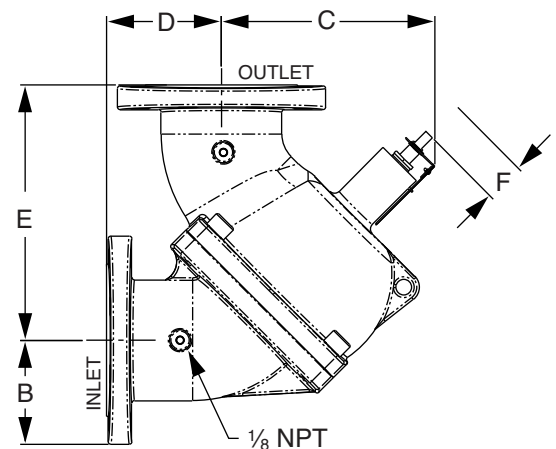
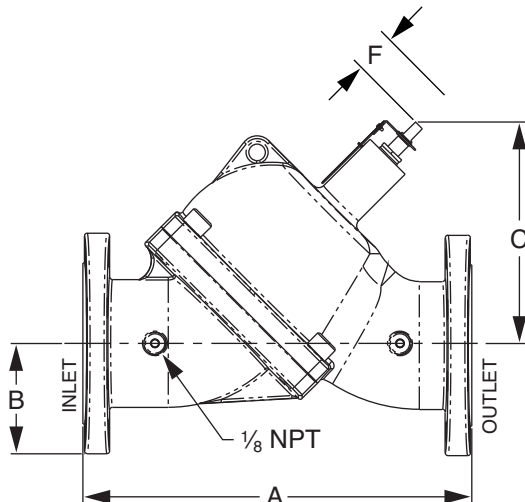

**PRESSURE TEMPERATURE RATINGS**

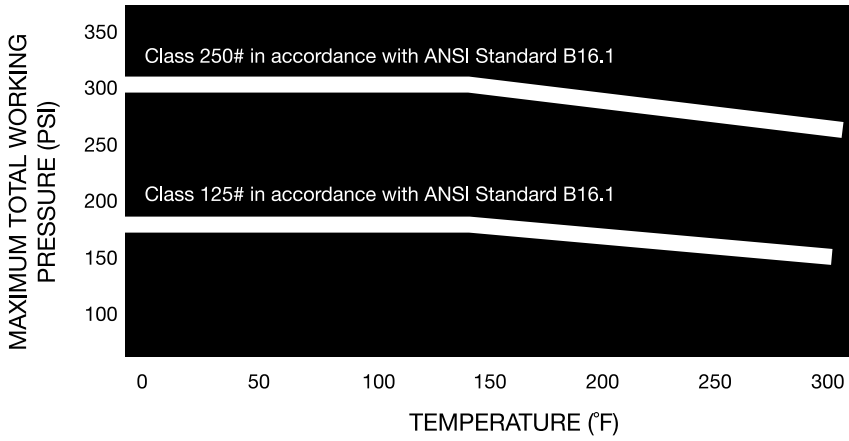

**OPERATING SPECIFICATIONS**

	Standard	Optional
Flange	Class 125*	Class 250*
Pressure	175 PSIG* (1210 KPA)	300 PSIG* (2070 KPA)
Temperature	250°F (120°C**)	250°F (120°C**)

\* Per Pressure Temperature Ratings chart to left.

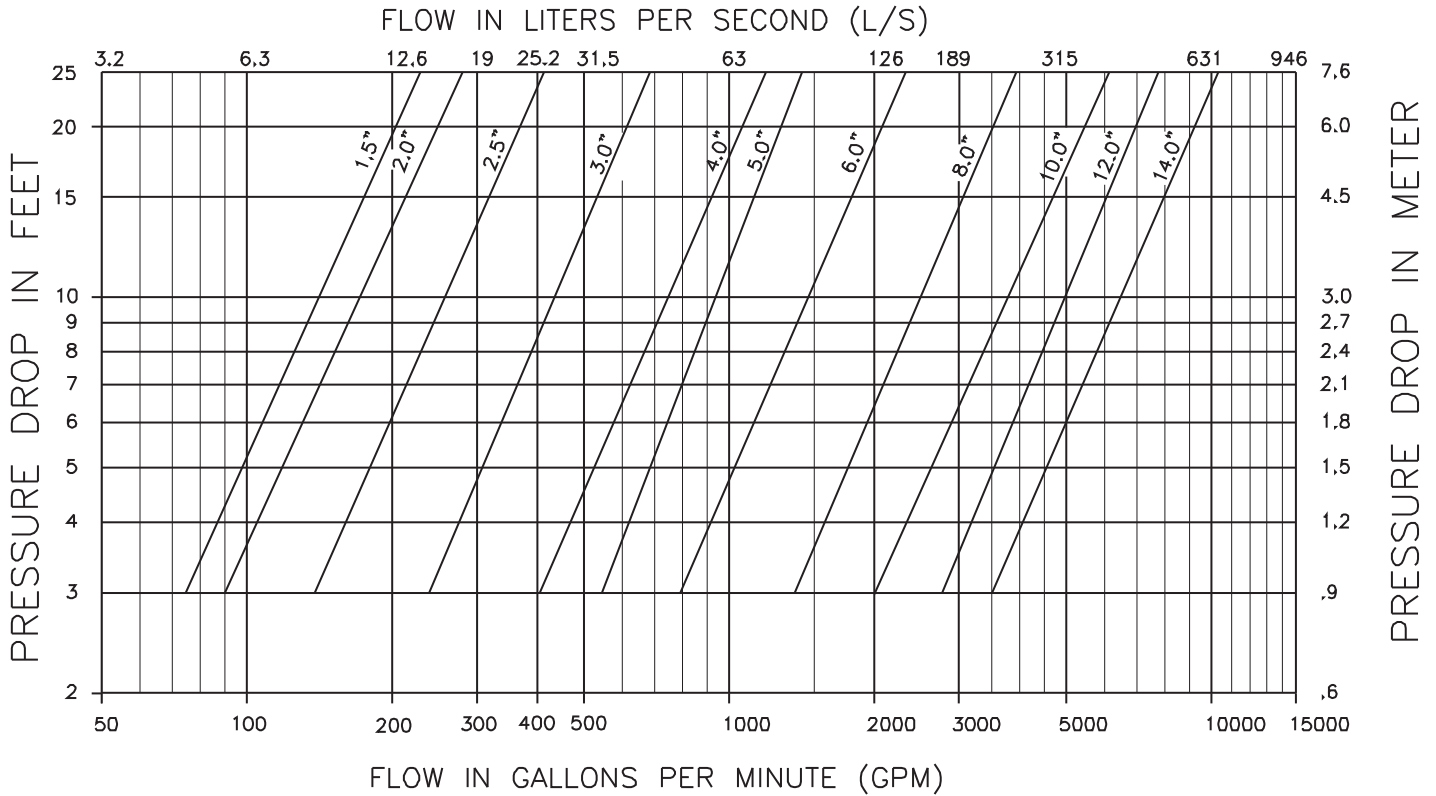

**Taco Comfort Solutions™** A Taco Group Company

Taco, Inc., 1160 Cranston Street, Cranston, RI 02920 | Tel: (401) 942-8000 | FAX: (401) 942-2360

Taco (Canada), Ltd., 8450 Lawson Road, Suite #3, Milton, Ontario L9T 0J8 | Tel: (905) 564-9422 | FAX: (905) 564-9436

Visit our web site: [www.TacoComfort.com](http://www.TacoComfort.com) | Printed in USA | ©2015 Taco, Inc.

