

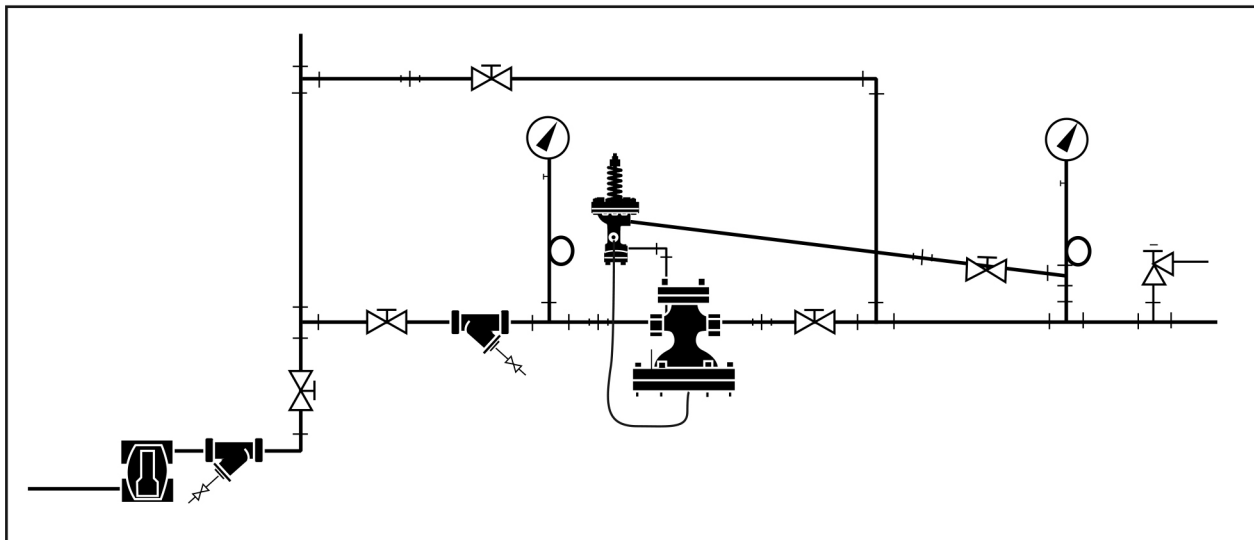

# Hoffman Specialty<sup>®</sup> Pilot Operated Pressure and/or Temperature Steam Regulators Series 2000

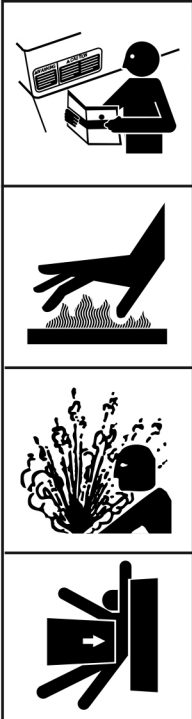

## **WARNING**



- Before using product, read and understand instructions.
- Save these instructions for future reference.
- All work must be performed by qualified personnel trained in the proper application, installation, and maintenance of steam systems in accordance with all applicable codes and ordinances.
- To prevent serious burns, wear heat resistant gloves when opening and closing steam valves, or handling hot equipment.
- To prevent serious personal injury from steam pipe blow down, connect a temporary pipe between the steam pipe opening and a drain, or stand at least 100 ft. (30m) from the front of the pipe opening.
- To prevent property damage, personal injury, or death, cap off the gate valves if they are not connected to a drain and when they are not in use for test or pressure relief.

Failure to follow this warning could cause property damage, personal injury or death.

# PLANNING THE INSTALLATION

## Planning for the Main Valve Installation

1. The regulator main valve must be located in an accessible straight run of horizontal piping.  
NOTE: Main valve must be installed with diaphragm located on bottom, as shown in Main Valve Installation illustration, page 3.
2. Allow clearance on top of the main valve to remove the cover plate to inspect and service the valve.
3. Allow clearance under the main valve diaphragm cover to replace diaphragms and drop out the stem for service.
4. Piping should be sized per good engineering practice. HVAC applications generally use 6,000 FPM velocity. Industrial applications generally use 8,000 to 10,000 FPM.
5. Blow out all piping with steam or compressed air before installing the main valve to remove mill scale and dirt.
6. Use long radius elbows in the low pressure piping. Avoid the use of bull-headed tees.
7. Provide a bypass line with a globe valve to allow inspection without interrupting service.
8. Install pressure gauges on inlet and outlet sides of regulator to indicate system performance.
9. Install drip traps to prevent:
  - Accumulation of condensate that can cause water hammer and destroy the main valve and pilot diaphragms.
  - Slow response times that cause temperature or pressure fluctuations.
10. Install "Y" Strainers in steam lines with the dirt pocket turned to the side to prevent collection of condensate that can be carried into the regulator and cause water hammer.

## Planning for the Pilot Installation

1. The pilot valves can be installed on either side of the main valve. The main valve is shipped with the U-tubing and the bleed orifice installed for left-hand side mounting of the pilot valves. (U-tubing is mounted on the right-hand side and the bleed orifice is installed on the left-hand side.)  
If right-hand side mounting of the pilot(s) is desired, the U-tubing and the bleed orifice must be relocated to the opposite sides of the main valve.  
*Note: Right-hand side and left-hand side positioning is determined when the main valve inlet directly faces the observer.*
2. Determine which pilot(s) are to be used for the installation. Multiple pilots can be used in combination on one main valve. Mount the pilot(s) as follows:
  - SLD Solenoid Pilot  
Always mount closest to the main valve.

11. Install pressure relief valves in accordance with local and national codes. The relief valve must be capable of passing the full capacity of the regulator with its largest seat trim.

Select the relief valve opening set point pressure based on the downstream pressure from the regulator. The actual relief valve set point pressure depends on the relationship of the flow (load) to the main valve rated capacity.

*For systems with spring or air pilots:*

Determine the relief pressure set point pressure for systems as follows:

Downstream System Pressure (DSP)	Flow (Load) Condition	Relief valve opening set point pressure
< 35 psig	< 50% of capacity	DSP + 5 psig
< 35 psig	≥ 51% of capacity	(1.1 x DSP) + 5 psig
≥36 psig	< 50% of capacity	DSP + 10 psig
≥36 psig	≥ 51% of capacity	(1.1 x DSP) + 10 psig

*For systems with temperature pilots only:*

The steam system relief valve opening set point pressure is based on the supply steam inlet pressure to the regulator and must be set as follows:

Supply Steam Inlet Pressure (SSIP)	Relief valve opening set point pressure
< 35 psig	SSIP + 5 psig
≥36 psig	SSIP + 10 psig

12. Locate temperature regulators close to the temperature sensing location. The temperature pilot capillary tube must allow the sensing bulb to be fully inserted into the system fluid.

- SPS Spring or AP Air Pressure Pilots  
*When used in combination with other pilots, always mount spring or air pilots furthest from the main valve.*
- STPA Temperature Pilot  
*When used with pressure pilot mount closest to main valve.*  
*When used with pressure and solenoid pilots – mount between pressure and solenoid pilots.*
- 315 PNT or 240PNT Pneumatic Temperature Pilots  
Mounted remotely from main valve.
- GT610-IP Electronic Pilot (used with customer supplied temperature sensor and controller)  
Mounted remotely from main valve.

3. Hardware kits containing steel pipe nipples and copper tube lines are required to mount the pilots. Refer to "Mounting Hardware for Pilot Installation" Page 4.

# INSTALLATION DETAIL

## Main Valve Installation

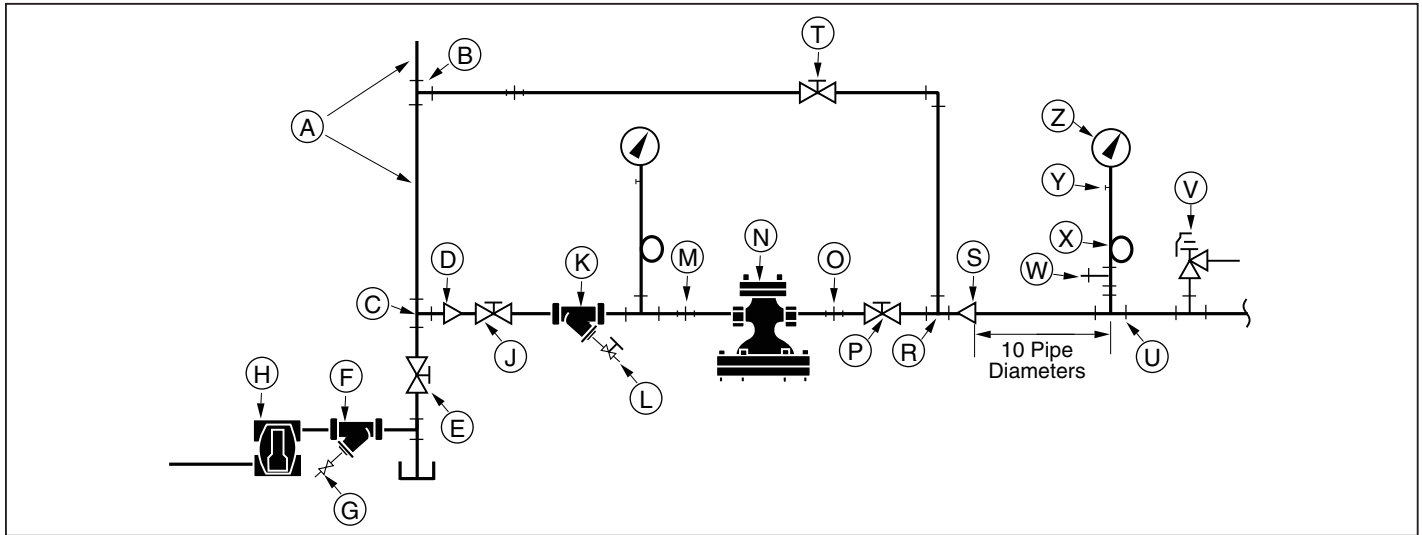

1. Connect a steam line (A) from the steam supply to the area where regulator valve is to be located. Install tee fittings (B) for a bypass line, and (C) for the regulator line.  
*Note: Drip traps prevent condensate from collecting in the piping during light loads or when the regulator is closed. Collected condensate in the piping ahead of the regulator can cause water hammer when the regulator opens.*
2. Install a shut off valve (E) to allow servicing the trap.
3. Provide a dirt pocket ahead of the strainer to allow large solids to drop out.
4. Install a drip trap (H), Y-strainer (F) equipped with a screen and blow down valve (G).
5. Cap the blow down valve outlet to prevent steam discharge due to accidental opening of valve.
6. Connect a horizontal pipe from tee (C).
7. Connect a reducer (D), if required, to reduce the steam line to the pipe size of the main valve.  
*Use additional reducers when the pipe needs to be reduced more than two pipe sizes. When noise is a concern, reducers should not have more than a 15 degree taper.*
8. Install shut off valve (J) and Y- strainer (K). Turn the strainer so that the screen is horizontal to prevent condensate from collecting in the screen pocket.  
*Condensate pockets can carry with the steam flow, causing water hammer that can destroy the main valve diaphragms.*
9. Install a strainer blow down valve (L).
10. Cap the blow down valve outlet to prevent steam discharge due to accidental opening of valve.
11. Install tee, siphon loop tube, petcock, and pressure gauge.
12. On **NPT sized regulator valves**, install a pipe union (M) to allow regulator removal for service or replacement.
13. Use compressed air or steam to clean piping before installing the regulator.
  - Cap off the end of the steam line.
  - Remove caps from the strainer blow down valves (G) and (L).
  - Turn on the steam or air to full pressure and allow it to blow down for five minutes.
  - Close off compressed air or steam.
  - Allow piping to cool below 100°F.
  - Reinstall end of line caps on blow down valves.
  - Remove cap from end of the steam line.
14. Install main valve (N) with the direction arrow pointing to the low-pressure side outlet piping.  
**NPT sized regulator valves:**
  - Use pipe sealant on male threads only, keeping the sealant out of the system.
  - Use a wrench on the flats of the body to tighten the joint.
  - Use the wrench on the side of the body that is being tightened to prevent stress and distortion on the body.**Flanged regulator valves:**
  - Inspect flange surfaces and gaskets.
  - Tighten flange bolts using a star pattern. Uneven bolting may cause steam leakage.
15. Install silencer orifice plate (when used) immediately after the main valve:  
**NPT sized regulator valves:** Install orifice plate between two ASME flanges.  
**Flanged regulator valves:** Install the orifice plate between the valve flange and the outlet pipe flange.
16. On **NPT sized regulator valves**, install a pipe union (O) to allow regulator removal for service or replacement.
17. Install gate valve (P).
18. Install pipe tee (R) for bypass connection.

19. Install the bypass piping and globe valve (T).
  - Use the same size pipe for the bypass piping and globe valve in the bypass line as the main valve (N) to allow manual regulation during service of regulator.
  - Support piping to remove any stress from the regulator valve body before connecting to the system.
  - Make sure pipes and flanges are properly aligned to prevent stress on the regulator valve body.
20. Install pipe reducer (S) to increase the pipe size, if necessary, to meet the velocity requirements.  
*Use additional reducers when the pipe needs to be increased more than two pipe sizes.*
21. Install a 1/4 NPT pipe tapping (U) at least 10 pipe diameters downstream in a straight run of the enlarged pipe for the pressure gauge and feedback line (for spring and/or air pilots) connection.

*Note: For heat exchanger shell applications, it is recommended that the feedback line and pressure gauge be installed directly into the heat exchanger shell.*

22. Install pressure relief valve (V) in the downstream piping as required by codes.
23. Install a tee fitting (W) for pressure feedback line.
24. Install a siphon loop tube (X), petcock (Y) and pressure gauge (Z) in vertical port of tee fitting (W).
25. Connect system piping to complete the installation.
26. Refer to "Pilot Installation" for pilot mounting and piping instructions.

## PILOT INSTALLATION

### Mounting Hardware for Pilot Installation

**Kit A** – For spring or air pilots only or in combination with temperature or solenoid pilots.

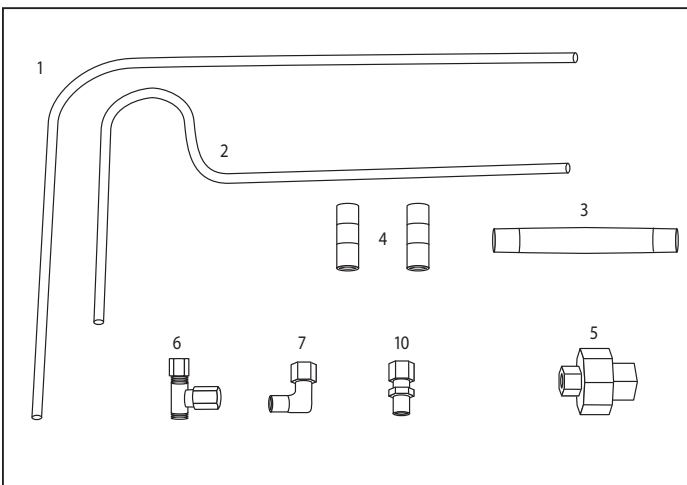

**Kit B** – For temperature pilot or solenoid pilot only.

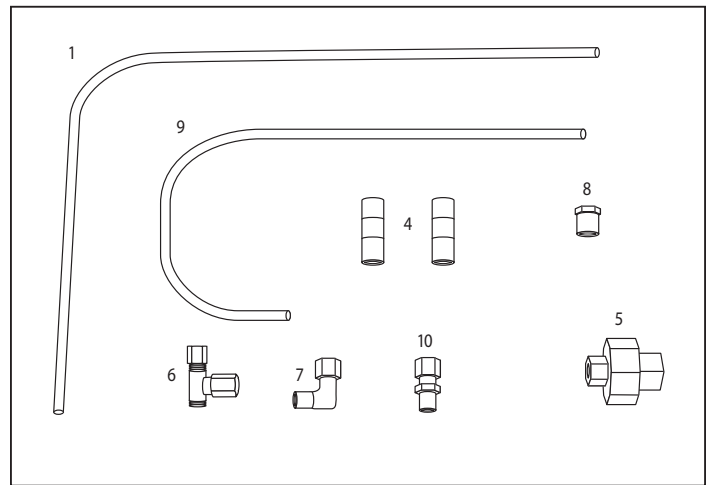

### Hardware Kit Components

No	Part Description	Kit A	Kit B
1	L-Tubing; from main valve bottom Elbow connection to tee fitting Branch connection.	X	X
2	S-Tubing; from bleed orifice fitting to tee fitting on pilot.	X	
3	Nipple, 1/4 NPT x 4" (101mm)	X	
4	Nipple, 1/4 NPT x 1-1/2" (38mm) (2)	X	X
5	Union Connection, 1/4 NPT Female	X	X
6	Tee fitting	X	X
7	L-fitting	X	X
8	Bushing		X
9	J-Tubing; From bleed orifice fitting to tee fitting on pilot.		X
10	1/8" Tubing connector	X	X

### 1. L-Tube

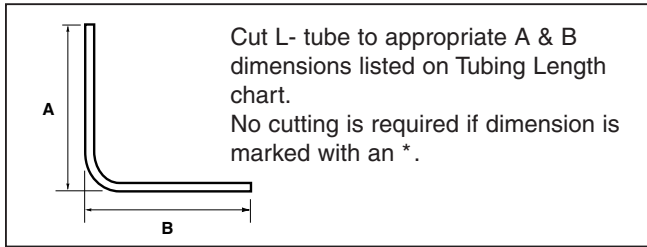

### 9. J-Tube

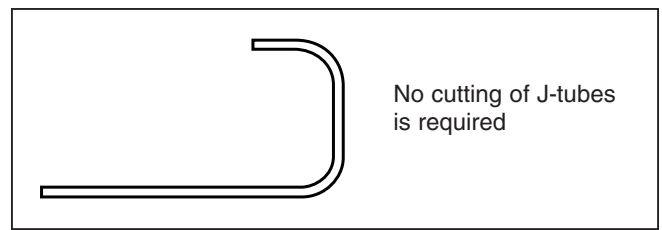

### 2. S-Tube

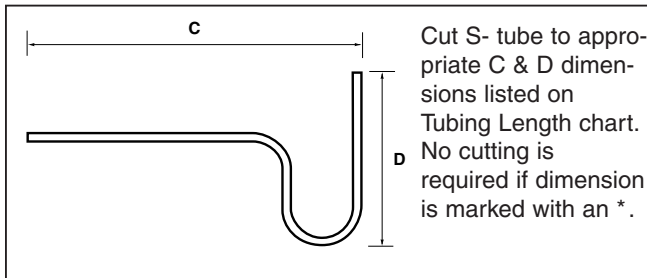

### Tubing Length

PILOT	MAIN VALVE SIZE	DIMENSIONS							
		A		B		C		D	
		In	mm	In	mm	In	mm	In	mm
Spring or Air	1/2 NPT, 3/4 NPT, 1 NPT	6.0	152	7.6	178	6.4	163	3.5	89
	1-1/4 NPT, 1-1/2 NPT	6.8	173	8.1	206	6.4	163	4.8	122
	2 NPT, 2 (50)	* 8.6	218	8.2	208	6.4	163	* 5.7	145
	2-1/2 (65)	10.6	269	9.1	231	6.4	163	5.9	150
	3 (80)	11.2	284	9.4	239	6.4	163	6.4	162
	4 (100)	13.0	330	10.3	262	6.4	163	7.9	200
	6 (150)	*16.6	422	12.3	312	6.4	163	* 9.5	241
Combination Pilots	1/2 NPT, 3/4 NPT, 1 NPT	6.0	152	11.3	287	*10.0	254	3.5	89
	1-1/4 NPT, 1-1/2 NPT	6.8	173	11.7	297	*10.0	254	4.8	122
	2 NPT, 2 (50)	* 8.6	218	* 11.9	302	*10.0	254	* 5.7	145
	2-1/2 (65)	10.6	269	12.8	325	*10.0	254	5.9	150
	3 (80)	11.2	284	13.1	333	*10.0	254	6.4	162
	4 (100)	13.0	330	13.9	353	*10.0	254	7.9	200
	6 (150)	*16.6	422	* 14.9	378	*10.0	254	* 9.5	241
Temperature	1/2 NPT, 3/4 NPT, 1 NPT	5.2	132	7.9	200				
	1-1/4 NPT, 1-1/2 NPT	6.0	152	8.6	218				
	2 NPT, 2 (50)	7.8	198	8.8	223				
	2-1/2 (65)	9.8	249	9.7	246				
	3 (80)	10.4	264	10.0	254				
	4 (100)	12.2	310	10.9	277				
	6 (150)	15.8	401	12.0	305				

\* No cutting of tube length is required.

## Bleed Orifice

The function of the bleed orifice is to bleed steam off the main valve diaphragm when the pilot(s) close(s). A 1/16" (1.6mm) diameter orifice is standard, and is installed in the outlet side of the main valve when shipped. This diameter orifice is used in most applications.

In special situations, the bleed orifice may be drilled out to 3/32" (2.4mm) diameter to produce faster closing time of the main valve and thus improve response time.

- A 3/32 in. (2.4mm) diameter orifice should **NOT** be used in conjunction with a temperature pilot, as accuracy of temperature control will be reduced.

- Typical applications for 3/32 in (2.4mm) diameter bleed orifice may include:
  - Pressure differential across the reducing valve is 50 psig (3.5 bar) or greater.
  - High pressure PRV on a 2-stage pressure reducing station.
  - Pressure reducing valve with a fast acting pneumatic temperature regulator downstream of the main valve.

## Pilot Installation Detail

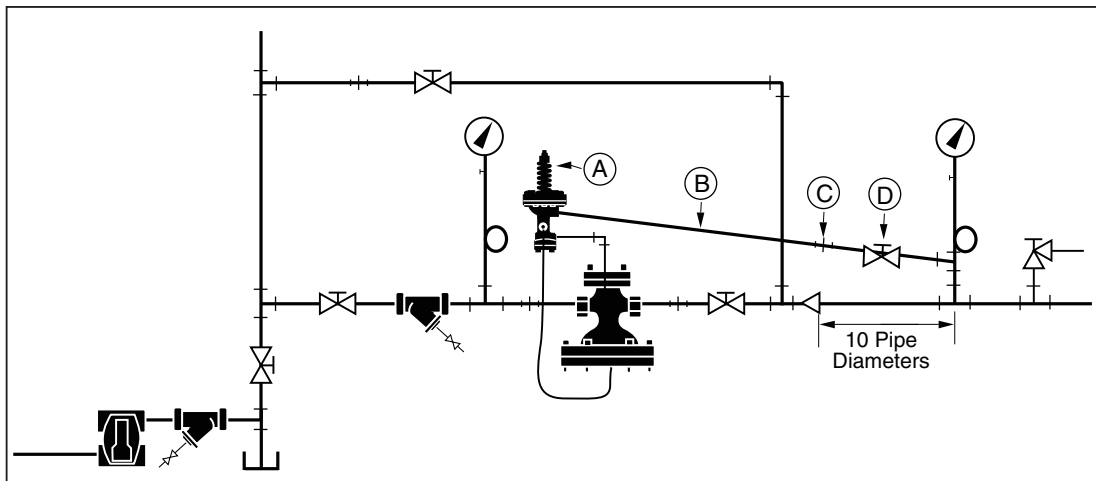

### Applies to All Pilots

1. The pilot valve(s) can be installed on either side of the main valve. The main valve is shipped with the U-tubing and the bleed orifice installed for left-hand side mounting of the pilot valve(s). If right-hand side mounting of the pilot(s) is desired, the U-tubing and the bleed orifice must be relocated to the opposite sides of the main valve.

*Note: Right-hand side and left-hand side positioning is determined when the main valve inlet directly faces the observer.*

2. Make sure the bleed orifice is installed in the 1/8 NPT tapping on the outlet end of the main valve on the opposite side from the U-tubing. Remove the 1/8 NPT pipe plug from the bleed orifice and replace it with a 1/8 NPT x 1/4" (6mm) OD tubing, straight compression fitting (from the hardware kit).
3. Install the 1/4 NPT x 1-1/2" (38mm) nipple and half of the union connection (from the hardware kit) on the inlet end of the main valve.

4. Use the 1/4 NPT x 4" (101mm) nipple and the remaining half of the union connection (from the hardware kit) to mount the first pilot. Mount additional pilots as required using 1/4" steel pipe nipples.
5. Install the copper tee fitting (from the hardware kit) in the 1/8 NPT signal tapping on the side of the last pilot with the tee pointing down.
6. Install the L-fitting (from the hardware kit) in the tapping at the center of the main valve diaphragm cover.

*Note: For steps 7 and 8, trim the length of the copper tubing as required (see "Tubing Length Chart", page 5) to make a neat installation. **Be sure to ream the tube to the full tube diameter after cutting.***

7. Install the S- or J-copper tubing (from the hardware kit) from the tee fitting to the bleed orifice.
8. Install the L- copper tubing (from the hardware kit) from the bottom of the tee fitting to the L-fitting in the main valve diaphragm cover.

## Spring/Air Pilots

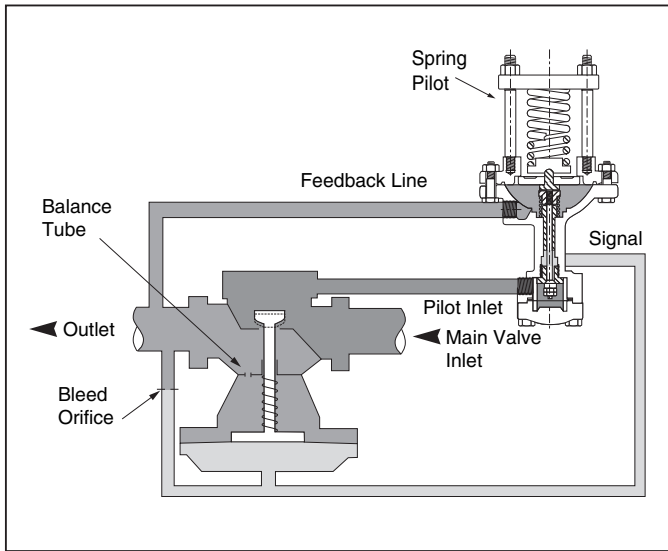

- The 1/4" feedback tapping must be connected to the downstream piping for either a spring or air pressure pilot:
  - Use 1/4 **black steel pipe** for the feedback line (B).
  - Install a 1/4 NPT shut off valve (D) and union (C) in this line to allow service of the pilot while operating the system on the by-pass line.
  - The feedback line **must** pitch away from the pilot to avoid erratic operation, excessive fouling and eliminate water pockets.
- When the regulator is used with a heat exchanger, connect the feedback line (B) to the heat exchanger shell. A tee fitting can be installed in the heat exchanger for a vacuum breaker connection.

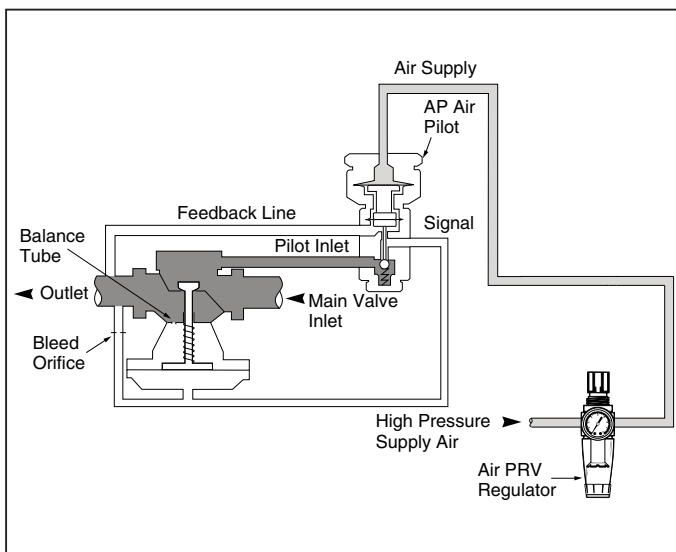

- For air pilot installations, connect the regulated air pressure supply to the top of the pilot bonnet.

## Temperature Pilots

### ⚠ CAUTION

Temperature pilot bulb will be immersed in the heated fluid. Before immersing, check compatibility of copper bulb with heated fluid. Failure to insure compatibility may cause property damage.

### ⚠ CAUTION

System should be supplied with overheat protection (such as temperature relief valve or aquastat solenoid combination) at 10°F over set temperature. Failure to follow this warning may result in property damage, personal injury, or death.

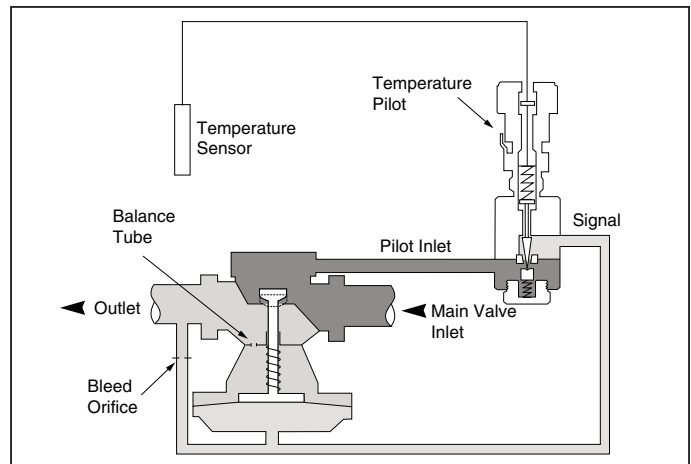

- When only a temperature pilot is used, the outlet tapping port must be reduced. Use the 1/8 x 1/4 NPT bushing (from the hardware kit) in the 1/4 NPT outlet.
- Insert the sensing bulb so the full length of the bulb is exposed to the fluid whose temperature is being controlled.
  - Use a 1/2 NPT compression fitting to install the bulb at the outlet of instantaneous heaters and in the middle of storage tanks.
  - The preferred bulb mounting when installed in the system piping is illustrated below:

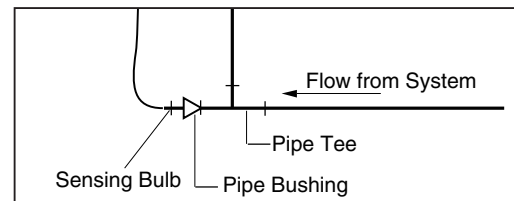

- Optional dry well (separable socket) allows the sensing bulb to be removed from the tank or piping without draining the system.
  - When using a dry well, coat the bulb with high temperature grease or heat transfer compound, to aid heat transfer.
  - Make sure that bulb and dry well are fully inserted into the fluid being controlled.

## Temperature and Spring Pilot Combination

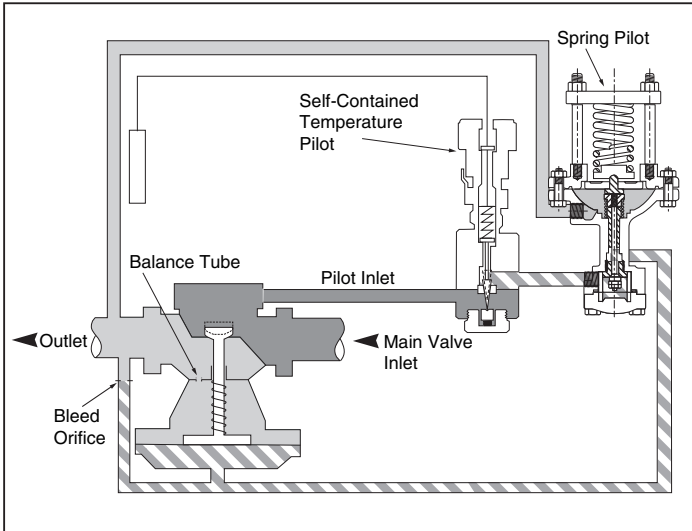

1. Install the temperature pilot next to the main valve.
2. Install a 1/4" NPT nipple between the outlet tapping port of the temperature pilot and the inlet port of the spring pilot.
3. The 1/4" feedback tapping port of the spring pilot must be connected to the downstream piping:
  - Use 1/4 **black steel pipe** for the feedback line.
  - Install a 1/4 NPT shut off valve and union in the feedback line to allow service of the pilot while operating the system on the by-pass line.
  - The feedback line **must** pitch away from the pilot to avoid erratic operation and excessive fouling and to eliminate water pockets.
4. When the regulator is used with a heat exchanger, connect the feedback line (B) (see illustration on page 6 to the heat exchanger shell. A tee fitting can be installed in the heat exchanger for a vacuum breaker connection.
5. Insert the sensing bulb of the temperature pilot so the full length of the bulb is exposed to the fluid whose temperature is being controlled.
  - a) Use a 1/2 NPT compression fitting to install the bulb at the outlet of instantaneous heaters and in the middle of storage tanks.
  - b) The preferred bulb mounting when installed in the system piping is illustrated on page 7.
  - c) Optional dry well (separable socket) allows the sensing bulb to be removed from the tank or piping without draining the system.
    - When using a dry well, coat the bulb with high temperature grease or heat transfer compound, to aid heat transfer.
    - Make sure that bulb and dry well are fully inserted into the fluid being controlled.

## Pneumatic Temperature and Air Pilot Combination

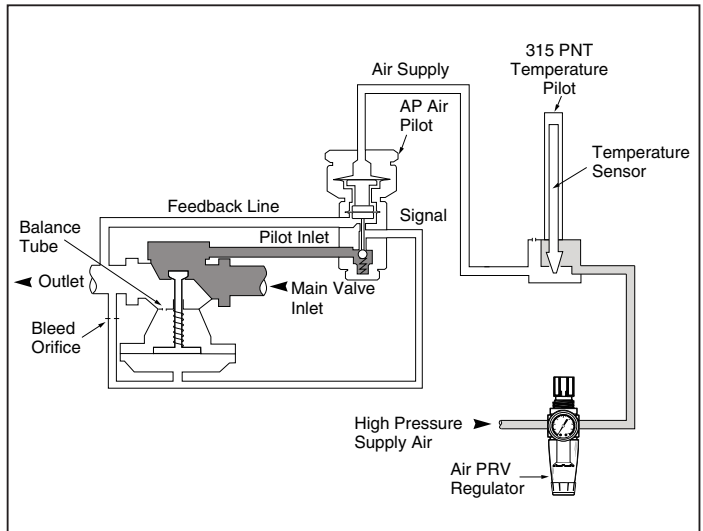

### Series 315 PNT Pilot

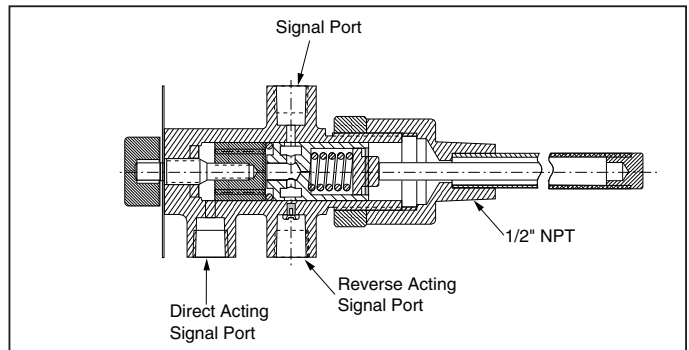

1. Connect a regulated air supply to the "Reverse Acting" inlet port of the 315 PNT pneumatic temperature pilot.
2. Do not plug the "Direct Acting" inlet port of the pneumatic temperature pilot. This port serves as an air bleed.
3. Connect the output "Signal" port of the pneumatic temperature pilot to the top of the AP-1A or AP-4A pneumatic air pilot.

### Series 240 PNT Pilot

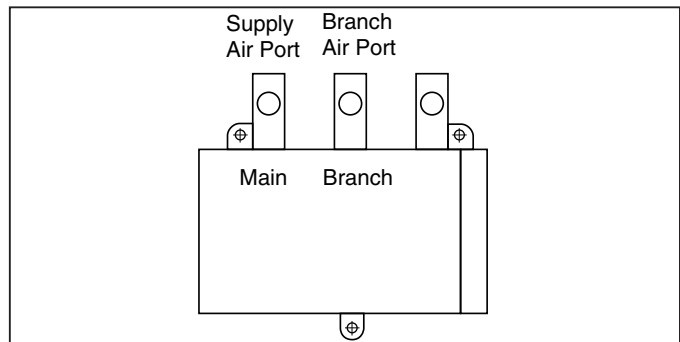

1. Connect a regulated air supply to the "Supply Air" port of the 240 PNT pneumatic temperature pilot.
2. Connect the output "Branch Air" port of the pneumatic temperature pilot to the top of the AP-1A or AP-4A pneumatic air pilot.



The following chart shows the maximum outlet steam pressure that can be obtained from the main valve. The outlet steam pressure is based on the air pressure from

the pneumatic temperature pilot to an AP-1A or AP-4A Pneumatic Pressure Pilot. Intermediate pressures can be interpolated from the chart.

PNT Air Signal Outlet Pressure		Maximum Steam Pressure from Main Valve			
		AP-1A Pressure Pilot		AP-4A Pressure Pilot	
psig	Bar	psig	Bar	psig	Bar
9	(0.62)	0	(0.00)	0	(0.00)
10	(0.69)	1	(0.07)	4	(0.28)
11	(0.76)	2	(0.14)	8	(0.55)
12	(0.83)	3	(0.21)	12	(0.82)
13	(0.90)	4	(0.28)	16	(1.10)
14	(0.97)	5	(0.35)	20	(1.38)
15	(1.04)	6	(0.41)	14	(1.66)
18	(1.24)	9	(0.62)	36	(2.50)
20	(1.38)	11	(1.76)	44	(3.00)
25	(1.73)	16	(1.10)	64	(4.40)
30	(2.07)	21	(1.45)	84	(5.80)

## SYSTEM START-UP

1. Make sure all strainer blow down valves are closed and capped to prevent accidental burns.
2. Open 1/4 NPT feedback control line shut-off valve.
3. Close inlet valve to main valve. Open outlet gate valve and all equipment drain valves. Allow system to drain completely.



### CAUTION

Never open a reducing valve without positive indication that the high pressure side is clear of condensate. Be sure no one is in area of any open end of pipes when steam is turned on. Failure to follow this caution may result in serious burns.

4. Make sure bypass globe valve is tightly closed.
  5. Release any actuating force on pilot(s).
    - Spring Close pilot valve by equally unscrewing adjusting nuts to release compression on the adjusting spring.
    - Air Adjust Air PRV Regulator to 0 psig (0.00 bar)
    - Temperature Set temperature adjusting knob to the lowest setting.
- NOTE: On **STPA-300 and STPA-400 pilots**, loosen the calibration set screw and move the pointer out the way. Gently turn the adjustment knob clockwise until the seat is completely closed. *This requires that the pilot be recalibrated, see "Adjusting Temperature Pilots", page 11.*
- Solenoid Make sure normally open solenoid is open or normally closed solenoid is closed.
6. Slightly open steam supply inlet valve. Open only enough to allow steam into the system.



### CAUTION

Hearing protection is required if drain valves are open to atmosphere. Failure to do so may result in hearing loss.

7. Apply a small amount of force to the pilots.
  - Spring Gradually compress adjusting spring by tightening adjusting nuts equally until the pilot valve opens.
  - Air Adjust Air PRV to allow pressure to build slightly until the air pilot valve opens.
  - Temperature Increase temperature setting a couple of degrees at a time.
  - Pneumatic Dial in temperature and adjust air supply pressure to 9 psi (0.62 bar).
8. Allow system to stabilize.
9. Open steam supply inlet valve slightly more. A little pressure will build on the inlet to the regulator, which allows it to open and steam to flow.
10. Close all equipment drain valves.
11. Open supply inlet valve more.
12. Allow system to stabilize.
13. **Check for any leaks.** Allow time for the piping to heat up and the drip trap to drain condensate.
14. Slowly allow pressure to build until the inlet gate valve is about half open. If there are no problems open inlet gate valve completely.
15. Refer to "Adjusting Pilot(s)", page 11, for final pilot adjustments.

---

## ADJUSTING PILOTS

### Spring/Air Pilots

Adjust spring/air pilot to control the system at desired pressure. The system pressure can be set for full steam or partial steam flow.

**Full Steam Flow** – If the spring pilot is adjusted to the required reduced pressure while the system is running at full steam flow, then the reduced pressure will rise approximately 10% when the system is running at low steam flow.

**Partial Steam Flow** – If the spring pilot is adjusted to the required reduced pressure while the system is running at 5 – 10% of full steam flow, the reduced pressure will fall (droop) approximately 10% when the system is running at full steam flow.

### Spring Pilot

1. To increase downstream pressure, increase compression on the adjusting spring by tightening the adjusting nuts an equal amount.
2. To decrease downstream pressure, release compression on the adjusting spring by loosening the adjusting nuts an equal amount.

### Air Pilot

1. To increase downstream pressure, increase the outlet pressure from the air regulator. The pilot should open at approximately 9 psig (0.62 bar).
2. To decrease downstream pressure, decrease the outlet pressure from the air regulator.

### Temperature Pilot

1. To increase temperature, loosen Allen lock screw and turn adjusting knob counterclockwise. Then securely tighten lock screw.
2. To decrease temperature, loosen Allen lock screw and turn adjusting knob clockwise. Then securely tighten lock screw.
3. Once system is running, temperature can be set immediately.
  - Insert a thermometer in heated fluid.
  - When thermometer (in heated fluid) indicates temperature is 5°F (3°C) below the required temperature, turn adjusting knob to lower temperature setting until steam flow stops.

- The calibrated temperature dial provides an approximate setting. If the temperature dial reading is slightly off from the thermometer reading, the dial should be recalibrated, as follows:
    - Loosen the set screw and turn the indicator and the mounting collar.
    - Retighten the set screw after making the adjustment.
4. Observe the temperature while the system is running.
  5. Adjust the sleeve until the desired temperature is reached.
  6. Tighten the dial set screw without turning the adjusting sleeve.
  7. When the temperature setting is complete, use the Allen head set screw to lock the knob.

### Temperature and Spring Pilot Combination

1. With the temperature pilot set to the highest temperature setting, adjust the spring pilot as noted above.
2. Adjust the temperature pilot according to instructions above.

### Pneumatic Temperature and Pneumatic Air Pilot Combination

With this combination, steam pressure is limited rather than controlled. The air regulator upstream of the air pilot and pneumatic temperature pilots controls the air pilot pressure setting. Through this combination, the air pilot limits the steam pressure delivered by the main valve. Therefore, only the temperature is adjusted.

1. The air supply to the PNT pilot should be set between 18 and 36 psig (1.24 – 2.5 bar).
2. Turn the adjusting knob on the pneumatic temperature pilot to the approximate desired operating temperature.
3. Insert a thermometer in heated fluid.
4. When the thermometer reaches the desired temperature, turn the PNT adjusting knob to indicate 9 psig (0.62 bar) on the PNT pressure gauge.
5. After conditions have stabilized, make adjustments as necessary.

For steam pressure limits, refer to "Maximum Steam Pressure from Main Valve" chart, page 9.

## MAINTENANCE

### Schedule

1. Initially every 2-3 days after start-up until system is clean.
2. Every 6 months thereafter.

### Procedure:

1. Inspect joints for leaks. Tighten bolts to stop leaks.
2. Open blow down valves on strainers.
3. Allow full pressure steam to pass for two minutes.
4. Close the blow down valves.
5. Observe system pressure and readjust if required.

### Control of Pressure and/or Temperature

1. Check to see that operating condition initial adjustments are still set.
2. Consider slightly altering the adjustment to see if the system responds appropriately.

### Solenoid Pilot Actuation

- Make sure solenoid is functioning properly.

### Strainers

- If screens in Y- strainers or pilot strainers are excessively dirty, system blowdown should be done once a week.

---

## TROUBLESHOOTING

Replace the regulator or pilot(s) when parts no longer operate properly. A new regulator is more economical than replacing individual parts, and will provide greater reliability.

### General Series 2000 Regulator System Troubleshooting Guidelines

#### Dead End Service

The seat leakage rate for metal single seated valves is .01% of rated flow, which is the industry standard. In applications where .01% flow will cause pressure or temperature override, seat lapping may be required. (See "Seat Lapping Procedure", page 14.)

#### Lifts in the Return Line on Heat Exchanger Applications

An elevated return line on a heat exchanger requires steam pressure to lift condensate. Condensate cannot drain from the heat exchanger shell until the internal pressure is sufficient to lift the condensate. The steam pressure required to lift the condensate remains in the heat exchanger shell. This can then cause a temperature overshoot and wide swings in temperature.

#### Steam Traps Undersized

Undersized steam traps can cause condensate to back up in a heat exchanger shell. Backed up condensate covers some of the tubes, reducing the heat transfer surface. If condensate backs up it may appear that the regulator is undersized. *When a temperature regulator is installed in the steam supply, size the steam trap based on 1/2 psig pressure differential.*

#### Failure to Install System Recirculation Pumps

A system without a recirculation pump will have wide temperature fluctuations during start-up. The regulator will also overshoot the temperature when system steam flow stops, trapping steam in the heat exchanger shell due to the response time required to close the regulator.

#### Low or Improper Outlet Pressure

**Cause:** Low inlet pressure  
**Solution:** Correct supply pressure from the boiler.  
Fully open supply valve.  
Check for upstream blockage.

**Cause:** The regulator is not properly adjusted.  
**Solution:** Readjust the pilot to desired operating pressure.

**Cause:** Feedback control line plugged.  
**Solution:** Remove and clean.

**Cause:** Bleed orifice missing or worn.  
**Solution:** Replace with new bleed orifice.

**Cause:** Main valve undersized.  
**Solution:** Check valve capacity against system load.  
Replace with correct size valve.

**Cause:** Strainer plugged.  
**Solution:** Blow down strainer screen or remove and clean screen.

#### Delivery Pressure High or Overrides

**Cause:** Bypass valve is open.  
**Solution:** Close bypass valve.

**Cause:** The regulator is not properly adjusted.  
**Solution:** Readjust the pilot to desired operating pressure.

**Cause:** Bleed orifice plugged.  
**Solution:** Clean or replace with new bleed orifice.

**Cause:** Dirt under the seat of main valve.  
**Solution:** Remove top cover plate and clean the seat surfaces.

**Cause:** Pilot valve malfunction.  
**Solution:** Refer to pilot valve test and repair procedures.

**Cause:** Main valve oversized.  
**Solution:** Check valve capacity against system load.  
Replace with correct size valve.

#### Delivery Pressure or Temperature Erratic

**Cause:** Pressure momentarily overshoots and then recedes to set pressure.  
**Solution:** Valve is not responding fast enough to react to the system. Drilling the bleed orifice out to 3/32" can increase the valve closing response time. *(Do not drill bleed orifice if a temperature pilot is used, as temperature accuracy will be decreased. Do not drill bleed orifice if differential pressure across the main valve is less than 40 psi as the valve may not fully open).*

**Cause:** Sensing line improperly located in the system.  
**Solution:** Relocate the sensing line to stable pressure area.

**Cause:** Temperature bulb improperly located.  
**Solution:** Relocate sensing bulb to make sure it is fully inserted into the system flow path.

## MAIN VALVE TESTING

All tests can be performed on main valve while it remains installed in the steam system, if there are gate valves located upstream and downstream of the main valve.

1. Isolate the main valve from steam pressure by closing the gate valves that are located upstream and downstream of the main valve.
2. If the main valve has a spring pilot or air pilot installed on it, close the shut off valve in the feedback line to the spring or air pilot.
3. Disconnect the pilot valves from the main valve.
4. Remove the orifice fitting from the 1/8" NPT port located on the side of the main valve.

### Test for Leakage between Plug and Seat:

1. Attach an air line to the 1/4" NPT port located on the side of the main valve inlet.
2. Apply air to the main valve inlet.
3. Check for air leakage from the 1/8" NPT port on the side of the main valve outlet.
  - Only a small amount of leakage is allowable.
  - Excessive leakage indicates either worn seat or plug, or the seat is held open by dirt.
  - Clean seat and plug and retest.
  - Replace parts if necessary.

### Test for Damaged Diaphragm:

1. Plug the 1/4 NPT port on the side of the main valve inlet.
2. Attach an air line containing a pressure regulating valve (PRV) and pressure gauge to the 1/8 NPT port located in the center of the lower diaphragm case of the main valve.
3. While adjusting the PRV in the air line, slowly increase the air pressure on the main valve diaphragms from 0 psig to 30 psig (0 to 2.1 bar). Slowly decrease the pressure back to 0 psig (0 bar). Repeat this step several times.
4. Check for air leakage from the open 1/8" NPT port on the side on the main valve outlet while the air pressure is being cycled.
  - No air leakage is permitted.
  - Large air leakage indicates the diaphragms are cracked or broken.
  - Replace new diaphragms as needed.

### Test for Restricted Movement:

1. Attach an air line containing a pressure regulating valve (PRV) and pressure gauge to the 1/8 NPT port located in the center of the lower diaphragm case of the main valve.
2. Disassemble the top cover from the main valve.
3. While adjusting the PRV in the air line:
  - Look in the top of the main valve
  - Slowly increase and decrease the air pressure to the lower diaphragm case.
4. Increase and decrease the air pressure several times.
5. Watch the movement of the main valve stem and plug.
6. Check for jerky movement or no movement.
  - The valve should stroke smoothly between the fully closed and fully open positions within the following pressure limits:

Main Valve Model	Pressure at Start of Stroke psig (bar)	Pressure at Full Stroke psig (bar)
2100 2200 2300	2.0 to 6.5 (0.14 to 4.5)	18.0 to 29.0 (1.2 to 2.0)
2150 2250	0.5 to 2.0 (0.03 to 0.14)	3.5 to 7.0 (0.24 to 5)

- Jerky movement indicates the valve stem and bushing are worn or diaphragms are damaged.
- Test for damaged diaphragms as described above.
- If diaphragms are not damaged, install a new stem and bushing.

## MAIN VALVE REPAIR

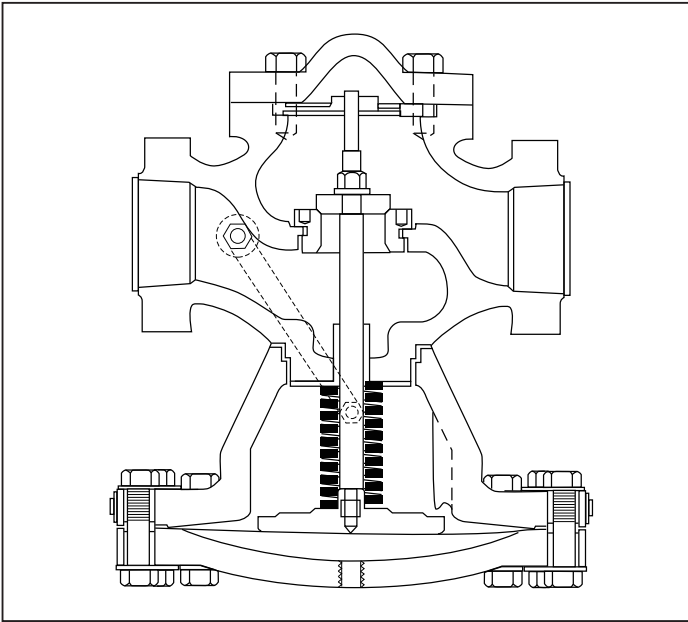

### Main Valve Repair

Main valves can be repaired without removing them from the piping.

Note: If a specific problem has been located during testing, only complete the steps required to complete repair of the damaged parts.

1. Isolate the main valve from the steam line. Make sure the internal pressure is 0 psig and allow the valve to cool to prevent injury.
2. Remove the main valve top cover plate (and stem top guide bushing on larger units).
3. Connect a source of regulated air pressure to the 1/8" NPT port located in the center of the lower diaphragm case of the main valve.
4. Load the main valve diaphragm chamber with 60-80 psig (4.2 to 5.6 bar) air to fully open the main valve seat.
5. Remove the stem nut, lock washer and plug from the stem by using an open end wrench on the stem nut and a hex Allen key in the end of the stem to keep the stem from rotating. **Important: do not release the air pressure from the main valve diaphragm with these parts off because the spring tension will damage the diaphragms.**

*Note: If the stem unscrews from the diaphragm button, remove the entire stem assembly from the main valve.*

- Carefully clamp on the stem with a pair of channel locks well above the guide bushing area and remove the nut, washer and plug.
  - Reinstall the valve stem using a hex wrench in the end of the stem to tighten the stem into the diaphragm button. See "Tightening Torque for Series 2000 Main Valve" chart, page 15.
6. Inspect the valve seat and plug for deep scratches or deposits.
    - Replace if necessary. A special seat tool is available to remove the seat from the body.

- Heating the seat with a torch may be required for seat removal.
7. Coat the threads and lower edge of seat flange with a high temperature non-hardening sealant before installing a new seat.
  8. Install a new seat. A new plug and seat will require lapping. See "Main Valve Seat Lapping Procedures," below.
  9. To continue disassembly:
    - Replace plug and stem nut onto stem to prevent damage to diaphragm when air pressure is released. Do not fully tighten nut.
    - Relieve air pressure from the diaphragm cover.
    - Unbolt the diaphragm cover and remove the diaphragms.
    - Compress the spring to lift the plug off the seat.
    - Remove the plug and allow the spring to relax.
    - Remove the button, stem and spring.
  10. Clean the stem and guide bushing. Replace if worn.
  11. Reassemble the valve in the reverse order of the disassembly procedure described above. See "Tightening Torque for Series 2000 Main Valve" chart, page 15.
  12. Return valve to service.
  13. Check for proper operation.

### Main Valve Seat Lapping Procedures

**Main valve seat lapping may be required on new installations where dead end service is required.**

**Lapping is also required when a new plug and seat are installed in a main valve.**

1. Isolate the main valve from the steam line. Make sure the internal pressure is 0 psig and allow the valve to cool to prevent injury.
2. Remove the main valve top cover plate. On larger units, remove the stem top guide bushing.
3. Connect a source of regulated air pressure to the 1/8" NPT port located in the center of the lower diaphragm case of the main valve.
4. Load the main valve diaphragm chamber with 60-80 psig air to fully open the main valve seat.
5. Remove the stem nut, lock washer and plug from the stem by using an open end wrench on the stem nut and a hex Allen key in the end of the stem to keep the stem from rotating. **Important: do not release the air pressure from the main valve diaphragm with these parts off because the spring tension will damage the diaphragms.**

*Note: If the stem unscrews from the diaphragm button, remove the entire stem assembly from the main valve.*

- Carefully clamp on the stem with a pair of channel locks well above the guide bushing area and remove the nut, washer and plug.
- Reinstall the valve stem using a hex wrench in the end of the stem to tighten the stem into the diaphragm button. See "Tightening Torque for

6. Inspect the valve seat and plug for deep scratches or deposits. Clean or replace if necessary.
7. Place a light film of valve lapping compound on the plug seating surface. Using 400 grit or finer lapping compound is recommended. (Generally available from automotive supply stores.)
8. Slide the plug on the valve stem. Do not install the lock washer or nut for lapping.
9. Slowly reduce the air loading on the main valve diaphragm until the plug touches on the valve seat.
  - Approximately 5 psig on Series 2100, 2200 and 2300 main valves.
  - 1 to 2 psig on Series 2150 and 2250 main valves.
10. Use the following procedure:
  - Rotate the plug back and forth about 90 degrees.
  - Use light hand pressure.
  - Lap for about 30 seconds.
  - Rotate the plug 120 degrees and repeat.
  - Rotate the plug another 120 degrees and repeat.
  - Remove the plug and use a clean cloth to wipe the plug.
  - The plug and seat should show a dull area where the lapping occurred.
  - Inspect to make sure the plug and seat made contact completely around the diameter.
  - If the contact area is not completely around the diameter repeat the process.
11. Increase the air loading to approximately 60-80 psig. Make sure the plug and seat are clean. Reinstall the plug, lock washer and nut. See "Tightening Torque for Series 2000 Main Valve" chart, below, for torque specification.
12. Reduce the air loading pressure on the main valve diaphragm area to 0 psig (0 bar). Observe the stem movement for smooth stroking.
13. Replace top cover and stem guide (if used) using a new gasket. Tighten the cover bolts to torque shown in the "Tightening Torque for Series 2000 Main Valve" chart, below.
14. Reconnect the steam tubing line to the main valve diaphragm. Slowly apply steam pressure and inspect for external leaks. Tighten as necessary or replace components to stop any leaks.
15. Return the main valve to service.

### Main Valve Diaphragm Replacement

A leak in the diaphragm will not allow full steam pressure to build up under the diaphragm and the valve will not fully open.

1. Isolate the main valve from the steam line. Make sure the internal pressure is 0 psig and allow the valve to cool to prevent injury.
  2. Remove the copper tubing line that connects to the diaphragm cover.
  3. Loosen all nuts on diaphragm cover bolts.
  4. Remove the bolts completely from *only one side* of the valve.
  5. Use a pair of needlenose pliers to remove the diaphragms from the side of the valve without the bolts.
  6. Insert new diaphragms and replace the bolts. Using a star pattern, tighten the diaphragm cover bolts, a minimum of three times, to the torque value shown in the "Tightening Torque for Series 2000 Main Valve" chart below.
- NOTE: On **2150 and 2250 main valves**, connect a source of regulated air pressure to the 1/4" NPT port located on the opposite side of the valve from the pilot inlet line. Load the inlet side of the valve with 30-50 psig (2.1 to 3.5 bar) pressure before tightening diaphragm cover bolts.
7. Reinstall the copper tubing line and return valve to service. Inspect for leaks.

### Tightening Torque for Series 2000 Main Valve

\* Tighten cover bolts a minimum of three times using an even star pattern.

Main Valve Size		Stem to Button		Nut to Stem		Seat		Top Cover Bolts *		Diaphragm Cover Bolts *	
in.	mm	lbf-ft	N-m	lbf-ft	N-m	lbf-ft	N-m	lbf-ft	N-m	lbf-ft	N-m
1/2 NPT		6	8	11	15	10	14	31	42	31	42
3/4 NPT		6	8	11	15	10	14	31	42	31	42
1 NPT		6	8	11	15	10	14	31	42	31	42
1-1/4 NPT		20	27	20	27	20	27	75	102	31	42
1-1/2 NPT		20	27	20	27	20	27	75	102	31	42
2 NPT		20	27	20	27	20	27	75	102	75	102
2	50	20	27	20	27	20	27	75	102	75	102
2-1/2	65	31	42	43	58	30	41	150	204	75	102
3	80	31	42	43	58	30	41	150	204	75	102
4	100	31	42	43	58	40	54	150	204	150	204
6	150	31	42	43	58	50	68	150	204	250	340

## PILOT VALVE TESTING AND REPAIR

### CAUTION

Close all steam lines that could pressurize any of the valve chambers before disassembling the system. Use caution when opening any section or valve chamber as there may be hot condensate trapped inside. Failure to do so may result in burns.

### SPRING PRESSURE PILOT

#### Spring Pilot Quick Test

1. Isolate the main valve from the steam line. Make sure the internal pressure is 0 psig and allow the valve to cool to prevent injury.
2. Disconnect the copper tubing line from the main valve diaphragm. Point tubing in a direction to prevent damage or burns.

### CAUTION

Quick test is done using live steam. Point tubing in a direction to prevent property damage or burns. To prevent serious burns, wear heat resistant gloves. Failure to follow this warning may result in property damage, personal injury or death.

3. Release compression on adjusting spring by loosening adjusting nuts an equal amount
4. If used in conjunction with a temperature pilot, set temperature setting higher than the bulb temperature.
5. Slightly open the shut off valve in the steam supply to the main valve and allow pressure to build.
6. Gradually compress the adjusting spring by tightening adjusting nuts equally until steam passes from the open end of the copper tubing line.
  - When used in conjunction with a temperature pilot, adjust pilot temperature setting to be higher than the bulb temperature.
  - The steam flow should discharge from the tubing line. Release some compression on the adjusting spring to reduce the pressure and the steam flow should stop.
  - A slight leakage is OK.
  - Repeat several times.
  - If the pilot does not start and stop the steam supply, the pilot should be repaired or replaced.
7. If the pilot responds properly, the problem is elsewhere in the system

#### Spring Pilot Bench Tests

1. Isolate the main valve from the steam line. Make sure the internal pressure is 0 psig and allow the valve to cool to prevent injury.
2. Disconnect the copper tubing lines and feedback line. Disconnect the pipe union and remove the pilots. If more than one pilot is used, unscrewing the 1/4" NPT pipe nipples should separate them.

3. Mount the spring pilot in a vice to test.
4. Release compression on adjusting spring by loosening adjusting nuts an equal amount.
5. Plug the 1/4" NPT **FEEDBACK LINE** port.
6. Install a 1/8" NPT pipe with a pressure gauge and shut off valve in the **SIGNAL LINE** port.
7. Connect a 30 psig air supply to the 1/4" NPT pilot **INLET** port.
8. **Test for seat and disc leakage:**
  - Open shut off valve from **SIGNAL LINE** port.
  - Apply air pressure at the **INLET** port.
  - Check for leakage from the **SIGNAL LINE** port.
  - If excessive leakage is indicated, replace the disc and seat. See "Spring Pressure Pilot Repair", page 17.
9. **Test for Valve movement.**
  - With 30 psig air pressure at the pilot **INLET** connection, close the shut off valve in the **SIGNAL LINE** pipe, and keep the **FEEDBACK LINE** port plugged.
  - Adjust the spring compression loading force until the outlet pressure is equal to 1/2 of air inlet supply.
  - Slowly open and close the shut off valve in the **SIGNAL LINE** pipe several times, the pressure should be the same each time the shut off valve is closed.
  - The pressure should respond smoothly.
  - If the pressure changes each time or if the reaction of the pressure gauge is jerky, the pilot valve movement is restricted.
  - Inspect the internal components for dirt or wear. Replace parts necessary. See "Spring Pressure Pilot Repair."
10. **Diaphragm test.**
  - With 30 psig air pressure at the pilot **INLET** connection, close the shut off valve in the **SIGNAL LINE** pipe, and keep the **FEEDBACK LINE** port plugged.
  - Adjust the spring compression loading force until the outlet pressure is equal to 1/2 of air inlet supply.
  - Check for air leakage around the diaphragm under the adjusting spring and pressure plate.
  - If air is leaking, replace the diaphragms. See "Spring Pressure Pilot Repair", page 17.



# SPRING PILOT REPAIR

## Disassembly

1. Isolate the main valve from the steam line. Make sure the internal pressure is 0 psig (0 bar) and allow the valve to cool to prevent injury.
2. Disconnect the copper tubing lines and feedback line. Disconnect the pipe union and remove the pilots from the main valve. If more than one pilot is used, unscrewing the 1/4" NPT pipe nipples should separate them.
3. Mount spring pilot in vise with adjusting spring up.
4. Release compression on adjusting spring (2) by loosening adjusting nuts (1) an equal amount.
5. Remove diaphragm nuts (3) and lift off cowl (4). Lift out diaphragm assembly (5, 6 & 7).
6. Disassemble diaphragm assembly by removing diaphragm screw (7) from pressure plate (5).
7. Remove blind flange bolts (16) and take off blind flange (15). Remove screen (12) and gasket (17).
8. Hold the pusher plate (8) and remove stem nuts (14). Lift out stem assembly (8 & 11) and valve spring (9). The disc (13) will drop off.
9. If the seat ring (10) requires replacement, remove it from pilot body with a socket wrench.

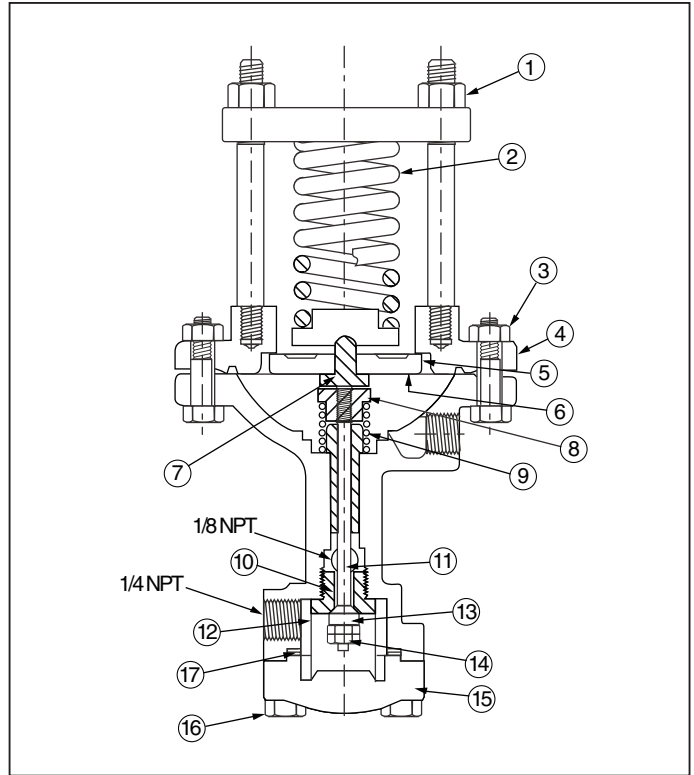

## Spring Pilot Inspection

1. Examine the seat and disc sealing surfaces for nicks or other signs of damage by pipeline debris. Slight imperfections may be removed by lapping the surfaces together. Otherwise the seat and disc must be replaced.
2. Examine the stem for build-up of pipeline contaminants or erosion. Remove any build-up with a wire brush and polish with very fine crocus cloth. Work carefully to avoid bending the stem.

## Spring Pilot Seat Lapping Operations

**Lap sparingly using 500 grit lapping compound and light pressure. Heavy grinding may cause galling, wide sealing surfaces and a grooved disc, all of which tend to produce leakage.**

Refer to lapping procedures in "Seat, Disc and Stem Replacement" below. After the sealing surfaces are lapped in, disassemble and clean all parts.

## Seat, Disc and Stem Replacement

1. Clean the body threads of old sealing compound using a wire brush. Apply new sealing compound (Copalite or equal) to the shoulder of seat ring. Let stand until tacky before installing in pilot body.
2. Lap in stem to disc joint with lapping compound.
3. Secure disc (13) to stem (11) with a stem nut (14). Insert this assembly into pilot body (omit valve spring).
4. Apply lapping compound to the disc and lap in the seat to disc joint. The stem is slotted for rotation with a screwdriver.

5. When lapping is complete, use a clean cloth to wipe the disc (13), seat ring (10) and stem (11).
6. Screw pusher plate (8) on stem (11). Holding disc against its seat, adjust the pusher plate (8) so that dimension C = 11/64" (4.4mm). A pilot travel setting gage is supplied with each repair kit.
7. Remove stem nut, being careful not to disturb the pusher plate adjustment. Lift stem out the top of the pilot. Grind off stem projection B flush with upper surface of the pusher plate.

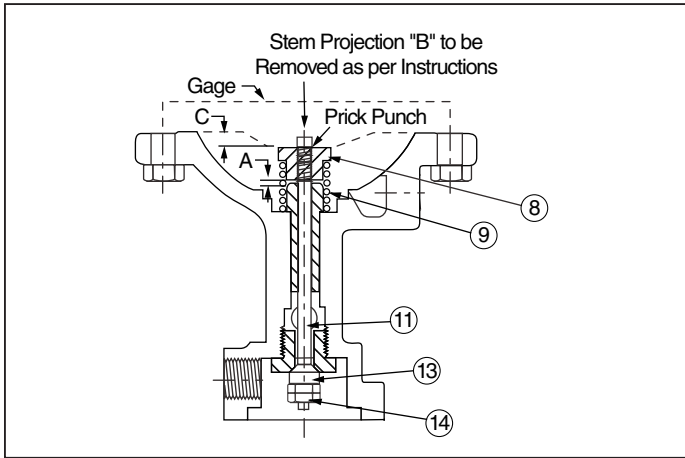

8. Reinsert stem into pilot body. Install disc and stem nut. Check dimension C and, if correct, lock the adjustment by prick punching the stem threads at several points. Work carefully to avoid bending the stem.
9. Scrape away burrs raised by the prick punching. Upper surface of pusher plate must be smooth and flat.
10. Check that the valve travel A = 3/64" (1.2mm). This need not be exact. Stem should move smoothly. Binding indicates a bent stem.
11. Remove stem nut and disc; withdraw stem. Install stem with valve spring disc and both stem nuts in place.

#### Spring Pilot Assembly

1. Reassemble the pilot in the reverse order of the disassembly procedure described above.
2. When replacing diaphragms, apply sealing compound (Copalite or equal) sparingly to the shoulder of the diaphragm screw (7).

Pressure Range Psig (bar)	Spring Color	Number of Diaphragms
2 – 30 (0.1 – 2.0)	BLUE	2
5 – 60 (0.3 – 4.1)	RED	2
20 – 175 (1.4 – 11.9)	GOLD	3

3. When replacing gaskets, be sure that any serrated sealing surfaces are cleaned of old gasket material.

## AIR PRESSURE PILOT

### Air Pilot Quick Test

1. Isolate the main valve from the steam line. Make sure the internal pressure is 0 psig and allow the valve to cool to prevent injury.
2. Disconnect the copper tubing line from the main valve diaphragm. Point tubing in a direction to prevent damage or burns.



### CAUTION

Quick test is done using live steam. Point tubing in a direction to prevent property damage or burns. To prevent serious burns, wear heat resistant gloves. Failure to follow this warning may result in property damage, personal injury or death.

3. Back off air loading pressure.
4. If used in conjunction with a temperature pilot, set temperature setting higher than the bulb temperature.
5. Slightly open the shut off valve in the steam supply to the main valve and allow pressure to build.

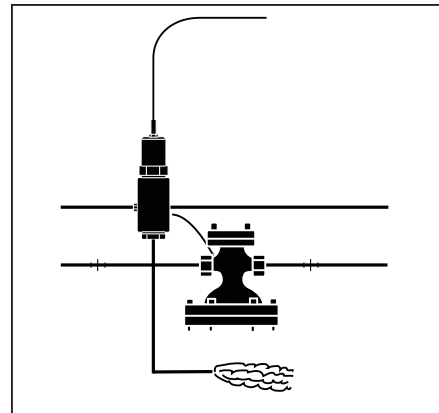

6. Increase the air loading pressure on the pilot until steam passes from the open end of the copper tubing line.
  - When used in conjunction with a temperature pilot, adjust pilot temperature setting to be higher than the bulb temperature.
  - The steam flow should discharge from the tubing line. Lower air pressure and the flow should stop.
  - A slight leakage is OK.
  - Repeat several times.
  - If the pilot does not start and stop the steam supply, the pilot should be repaired or replaced.
7. If the pilot responds properly the problem is elsewhere in the system.

## Air Pilot Bench Tests

1. Isolate the main valve from the steam line. Make sure the internal pressure is 0 psig and allow the valve to cool to prevent injury.
2. Disconnect the copper tubing lines and feedback line. Disconnect the pipe union and remove the pilots. If more than one pilot is used, unscrewing the 1/4" NPT pipe nipples should separate them.
3. Mount individual air pilot in a vice to test.
4. Plug the 1/4" NPT **FEEDBACK** tapping.
5. Install a 1/8" NPT pipe with a pressure gauge and shut off valve in the **SIGNAL** port.
6. Connect a 30 psig air supply to the pilot **IN** connection.
7. Test for seat and ball leakage.
  - Open shut off valve from **SIGNAL** port.
  - Apply air pressure at the **IN** port.
  - Check for leakage from the **SIGNAL** port. Only a small amount of leakage is allowable.
  - If excessive leakage is indicated replace the ball and seat. See "Air Pilot Repair."
8. **Test for Valve Movement.**
  - With 30 psig air pressure at the pilot Inlet connection, close the shut off valve in the **SIGNAL** pipe.
  - Load air pressure on the top of the pilot until pressure is equal to 1/2 of air supply.
  - Slowly open and close the shut off valve several times, the pressure should be the same each time the shut off valve is closed.

- The pressure should respond smoothly.
- If the pressure changes each time or if the reaction of the pressure gauge is jerky, the pilot valve movement is restricted.
- Inspect the internal components for dirt or wear.

## 9. Diaphragm test.

### AP-1A:

- With a 30 psig air supply to the **FEEDBACK** tapping, the **SIGNAL** line and **IN** tapings plugged, check for air leakage from the top of the pilot.
- If air is leaking, replace the diaphragms.

### AP-4A:

- With a 30 psig air supply to the **FEEDBACK** tapping, the **SIGNAL** line and **IN** tapings plugged, check for air leakage from the vent hole of the pilot.
- If air is leaking, replace the lower diaphragms.
- With a 30 psig air supply to the top of the pilot, the **SIGNAL** line tapping, **FEEDBACK** tapping and **IN** tapping plugged, check for air leakage from the vent hole of the pilot.
- If air is leaking, replace the upper diaphragms.
- With a 30 psig air supply to the top of the pilot, the **SIGNAL** line tapping, **FEEDBACK** tapping and **IN** tapping plugged, check for air leakage from the vent hole of the pilot.
- If air is leaking, replace the upper diaphragms.

## Air Pilot Disassembly

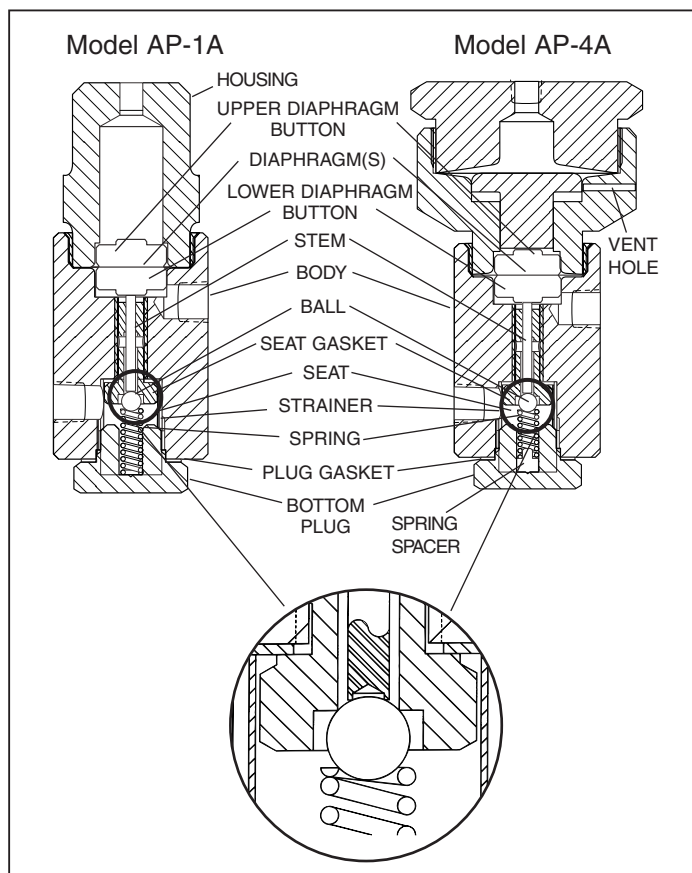

1. Isolate the main valve from the steam line. Make sure the internal pressure is 0 psig (0 bar) and allow the valve to cool to prevent injury.
2. Disconnect the copper tubing lines and feedback line.
3. Disconnect the pipe union and remove the pilots from the main valve.
4. If more than one pilot is used, unscrewing the 1/4" NPT pipe nipples should separate them.
5. Mount air pilot in vice with bottom up and unscrew the plug.
6. Remove the bottom plug and brass washer. Remove from vice and turn upright. The spring, ball, strainer and stem will drop out.
 

*Note: The bottom portion of Model AP-1A and AP-4A is the same. Model AP-4A has a small spring spacer below the spring.*
7. Mount the pilot in the vice again with the bottom up.
8. Remove the seat using a 9/16" thinwall socket.

## Air Pilot Disassembly (cont'd)

9. Inspect and clean all parts and gasket sealing areas. Replace any worn or damaged parts.
  - Reassemble using non-hardening sealant on the plug threads.
  - Note: The hollowed out end of the stem goes against the ball.
10. To service the upper end of the pilot:
  - Mount it in a vice with the top up.
  - Unscrew and remove the upper housing.
11. Remove upper diaphragm button, diaphragm(s) and lower diaphragm button.
 

*Note: Model AP-4A has 2 sets of diaphragms and a pusher spacer mounted between them.*
12. Inspect and clean all parts, replace diaphragm(s) and worn or defective items.
13. Diaphragms should be biased down by using air pressure in the top port before finally tightening housing to body.
14. Install stem with the counterbore end facing the ball. (See magnified view of the stem and ball below.) The flat end of the stem should face the lower diaphragm button.

## Tightening Torque: Models AP-1A and AP-4A Air Pilots

	lbf-ft	N-m
Bottom Cap	80 – 90	108 – 122
Housing to Body	100 – 120	136 – 163
Model AP-4A: Air cover to housing	150 – 170	204 – 231

## TEMPERATURE PILOT Temperature Pilot Testing

### CAUTION

Before removing sensing probe, the system must be drained and pressure relieved and cooled, unless a separable well is provided. Failure to follow this procedure may result in serious burns.

### CAUTION

Temperature pilot bulb will be inserted in the heated fluid. Before immersing check compatibility of copper bulb with the heated fluid. Failure to follow this caution may result in serious burns.

1. Isolate the main valve from the steam line. Make sure the internal pressure is 0 psig and allow the valve to cool to prevent injury.
2. Disconnect the copper tubing line from the main valve diaphragm. Point tubing in a direction to prevent damage or burns.

### CAUTION

This test is done using live steam. Point tubing in a direction to prevent property damage or burns. To prevent serious burns, wear heat resistant gloves. Failure to follow this warning may result in property damage, personal injury or death.

3. Back off temperature setting by turning the temperature knob. A setscrew in the adjusting knob locks the setting. Loosen the setscrew to turn the knob.
4. If used in conjunction with a spring pilot make sure the spring adjustment has the spring pilot open.
5. Slightly open the shut off valve in the steam supply to the main valve and allow pressure to build.
6. Increase the temperature setting on the pilot until steam passes from the open end of the copper tubing line.
7. Back off temperature setting and the steam flow should stop. A slight leakage is OK.
8. Repeat several times.
9. If the pilot does not start and stop the steam supply it should be repaired or replaced.
10. If the pilot responds properly the problem is elsewhere in the system.

## Temperature Pilot Repair

- Put pilot in vise with top up. Remove the bottom plug (4). The strainer (8), spring (5) and button (6) should drop out when the bottom plug is removed.
- Remove the seat (2) using a 9/16" thinwall socket. The valve plug (9) will drop out also.
- Clean and inspect all parts, lap plug (9) and seat (2) with 400 grit lapping compound. Replace if necessary.
- Apply non-hardening sealant to bottom plug (4) threads. Reassemble pilot.
- Retest pilot.

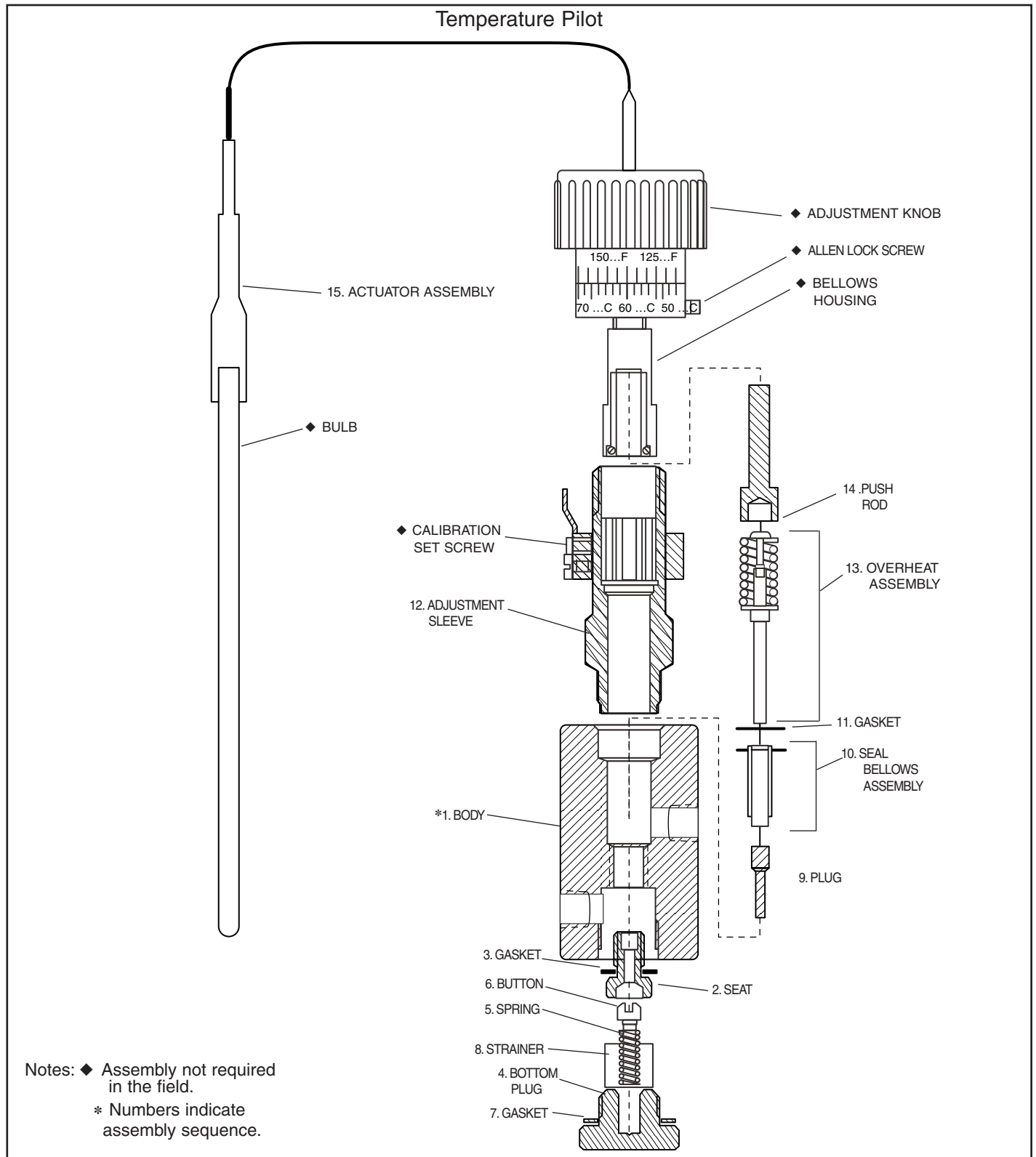

---

**Temperature Actuator Assembly Testing**

1. Loosen calibration set screw on indicator ring. Drop away from dial.
2. Loosen Allenlock set screw on knob assembly. Unscrew adjustment knob assembly from actuator.
3. Insert flat ended smooth wooden dowel into the bellows.

Note: Bellows should be firm. If it is spongy, the actuator has lost its liquid fill. For more precise testing, use a depth micrometer. The bellows should move 0.00057 inch (0.0144mm) per degree change of the sensing bulb.

4. If the actuator does not operate properly, it must be replaced.

**Temperature Actuator Assembly Installation**

1. Loosen the calibration ring screw and the adjustment knob screw.
2. Under normal conditions. Slowly rotate the knob counterclockwise to increase temperature, or clockwise to decrease temperature to achieve the desired system temperature.

3. Allow system temperature to stabilize at the desired set-point temperature and normal load conditions. Securely tighten the adjustment knob set screw.
4. Rotate calibration ring so that the indicator arrow is in alignment with the desired set-point temperature. Securely tighten the calibration ring set screw.

**Seal Bellows Replacement Assembly**

1. Remove actuator assembly. Complete steps 1-2 under "Temperature Actuator Assembly Testing" above.
2. Turn body assembly over with bottom plug up. The push rod and overheat assembly will drop out.
3. Place body assembly in vise with adjustment sleeve turned up.
4. Unthread adjustment sleeve from body.
5. Remove from vise and turn body over with bottom plug up. The brass washer, bellows assembly and plug will drop out.
6. Inspect parts and replace as necessary.
7. Reassemble and recalibrate actuator. Complete steps 1-5 under "Temperature Actuator Assembly Installation" above.

**Tightening Torque for Temperature Pilots**

	<b>lbf-ft</b>	<b>N-m</b>
Bottom Cap	80 – 90	108 – 122
Brass Sleeve to Body	80 – 90	108 – 122

## **COMMERCIAL WARRANTY**

**Warranty.** For goods sold to commercial buyers, Seller warrants the goods sold to Buyer hereunder (with the exception of membranes, seals, gaskets, elastomer materials, coatings and other “wear parts” or consumables all of which are not warranted except as otherwise provided in the quotation or sales form) will be (i) be built in accordance with the specifications referred to in the quotation or sales form, if such specifications are expressly made a part of this Agreement, and (ii) free from defects in material and workmanship for a period of one (1) year from the date of installation or two (2) years from the date of manufacture, whichever shall occur first, unless a longer period is specified in the product documentation (the “Warranty”).

Except as otherwise required by law, Seller shall, at its option and at no cost to Buyer, either repair or replace any product which fails to conform with the Warranty provided Buyer gives written notice to Seller of any defects in material or workmanship within ten (10) days of the date when any defects or non-conformance are first manifest. Under either repair or replacement option, Seller shall not be obligated to remove or pay for the removal of the defective product or install or pay for the installation of the replaced or repaired product and Buyer shall be responsible for all other costs, including, but not limited to, service costs, shipping fees and expenses. Seller shall have sole discretion as to the method or means of repair or replacement. Buyer’s failure to comply with Seller’s repair or replacement directions shall terminate Seller’s obligations under this Warranty and render the Warranty void. Any parts repaired or replaced under the Warranty are warranted only for the balance of the warranty period on the parts that were repaired or replaced. Seller shall have no warranty obligations to Buyer with respect to any product or parts of a product that have been: (a) repaired by third parties other than Seller or without Seller’s written approval; (b) subject to misuse, misapplication, neglect, alteration, accident, or physical damage; (c) used in a manner contrary to Seller’s instructions for installation, operation and maintenance; (d) damaged from ordinary wear and tear, corrosion, or chemical attack; (e) damaged due to abnormal conditions, vibration, failure to properly prime, or operation without flow; (f) damaged due to a defective power supply or improper electrical protection; or (g) damaged resulting from the use of accessory equipment not sold or approved by Seller. In any case of products not manufactured by Seller, there is no warranty from Seller; however, Seller will extend to Buyer any warranty received from Seller’s supplier of such products.

**THE FOREGOING WARRANTY IS EXCLUSIVE AND IN LIEU OF ANY AND ALL OTHER EXPRESS OR IMPLIED WARRANTIES, GUARANTEES, CONDITIONS OR TERMS OF WHATEVER NATURE RELATING TO THE GOODS PROVIDED HEREUNDER, INCLUDING WITHOUT LIMITATION ANY IMPLIED WARRANTIES OF MERCHANTABILITY AND FITNESS FOR A PARTICULAR PURPOSE, WHICH ARE HEREBY EXPRESSLY DISCLAIMED AND EXCLUDED. EXCEPT AS OTHERWISE REQUIRED BY LAW, BUYER’S EXCLUSIVE REMEDY AND SELLER’S AGGREGATE LIABILITY FOR BREACH OF ANY OF THE FOREGOING WARRANTIES ARE LIMITED TO REPAIRING OR REPLACING THE PRODUCT AND SHALL IN ALL CASES BE LIMITED TO THE AMOUNT PAID BY THE BUYER FOR THE DEFECTIVE PRODUCT. IN NO EVENT SHALL SELLER BE LIABLE FOR ANY OTHER FORM OF DAMAGES, WHETHER DIRECT, INDIRECT, LIQUIDATED, INCIDENTAL, CONSEQUENTIAL, PUNITIVE, EXEMPLARY OR SPECIAL DAMAGES, INCLUDING BUT NOT LIMITED TO LOSS OF PROFIT, LOSS OF ANTICIPATED SAVINGS OR REVENUE, LOSS OF INCOME, LOSS OF BUSINESS, LOSS OF PRODUCTION, LOSS OF OPPORTUNITY OR LOSS OF REPUTATION.**

## **LIMITED CONSUMER WARRANTY**

**Warranty.** For goods sold for personal, family or household purposes, Seller warrants the goods purchased hereunder (with the exception of membranes, seals, gaskets, elastomer materials, coatings and other “wear parts” or consumables all of which are not warranted except as otherwise provided in the quotation or sales form) will be free from defects in material and workmanship for a period of one (1) year from the date of installation or two (2) years from the product date code, whichever shall occur first, unless a longer period is provided by law or is specified in the product documentation (the “Warranty”).

Except as otherwise required by law, Seller shall, at its option and at no cost to Buyer, either repair or replace any product which fails to conform with the Warranty provided Buyer gives written notice to Seller of any defects in material or workmanship within ten (10) days of the date when any defects or non-conformance are first manifest. Under either repair or replacement option, Seller shall not be obligated to remove or pay for the removal of the defective product or install or pay for the installation of the replaced or repaired product and Buyer shall be responsible for all other costs, including, but not limited to, service costs, shipping fees and expenses. Seller shall have sole discretion as to the method or means of repair or replacement. Buyer's failure to comply with Seller's repair or replacement directions shall terminate Seller's obligations under this Warranty and render this Warranty void. Any parts repaired or replaced under the Warranty are warranted only for the balance of the warranty period on the parts that were repaired or replaced. The Warranty is conditioned on Buyer giving written notice to Seller of any defects in material or workmanship of warranted goods within ten (10) days of the date when any defects are first manifest.

Seller shall have no warranty obligations to Buyer with respect to any product or parts of a product that have been: (a) repaired by third parties other than Seller or without Seller's written approval; (b) subject to misuse, misapplication, neglect, alteration, accident, or physical damage; (c) used in a manner contrary to Seller's instructions for installation, operation and maintenance; (d) damaged from ordinary wear and tear, corrosion, or chemical attack; (e) damaged due to abnormal conditions, vibration, failure to properly prime, or operation without flow; (f) damaged due to a defective power supply or improper electrical protection; or (g) damaged resulting from the use of accessory equipment not sold or approved by Seller. In any case of products not manufactured by Seller, there is no warranty from Seller; however, Seller will extend to Buyer any warranty received from Seller's supplier of such products.

**THE FOREGOING WARRANTY IS PROVIDED IN PLACE OF ALL OTHER EXPRESS WARRANTIES. ALL IMPLIED WARRANTIES, INCLUDING BUT NOT LIMITED TO THE IMPLIED WARRANTIES OF MERCHANTABILITY AND FITNESS FOR A PARTICULAR PURPOSE, ARE LIMITED TO ONE (1) YEAR FROM THE DATE OF INSTALLATION OR TWO (2) YEARS FROM THE PRODUCT DATE CODE, WHICHEVER SHALL OCCUR FIRST. EXCEPT AS OTHERWISE REQUIRED BY LAW, BUYER'S EXCLUSIVE REMEDY AND SELLER'S AGGREGATE LIABILITY FOR BREACH OF ANY OF THE FOREGOING WARRANTIES ARE LIMITED TO REPAIRING OR REPLACING THE PRODUCT AND SHALL IN ALL CASES BE LIMITED TO THE AMOUNT PAID BY THE BUYER FOR THE DEFECTIVE PRODUCT. IN NO EVENT SHALL SELLER BE LIABLE FOR ANY OTHER FORM OF DAMAGES, WHETHER DIRECT, INDIRECT, LIQUIDATED, INCIDENTAL, CONSEQUENTIAL, PUNITIVE, EXEMPLARY OR SPECIAL DAMAGES, INCLUDING BUT NOT LIMITED TO LOSS OF PROFIT, LOSS OF ANTICIPATED SAVINGS OR REVENUE, LOSS OF INCOME, LOSS OF BUSINESS, LOSS OF PRODUCTION, LOSS OF OPPORTUNITY OR LOSS OF REPUTATION.**

Some states do not allow limitations on how long an implied warranty lasts, so the above limitation may not apply to you. Some states do not allow the exclusion or limitation of incidental or consequential damages, so the above exclusions may not apply to you. This warranty gives you specific legal rights, and you may also have other rights which may vary from state to state.

To make a warranty claim, check first with the dealer from whom you purchased the product or call +1-847-966-3700 for the name and location of the nearest dealer providing warranty service.



Xylem Inc.  
8200 N. Austin Avenue  
Morton Grove, Illinois 60053  
Phone: (847) 966-3700  
Fax: (847) 965-8379  
[www.bellgossett.com](http://www.bellgossett.com)

Bell & Gossett is a trademark of Xylem Inc. or one of its subsidiaries.  
© 2015 Xylem Inc. HS-601H June 2015 Part No. 510549

