

**11 Solid Reasons to Choose Hoffman**

- Engineered Reliability
- NPT Inlet, Vent, and Overflow Receiver Openings
- Field tested performance. Thousands installed and operating economically and efficiently
- Close Coupled Pump Design
- Mechanical Seal Construction
- Bronze Fitted Centrifugal Pump
- Stainless Steel Motor Shaft
- Renewable Bronze Wearing Ring
- Quiet, Ball Bearing Motor with Dual Voltages
- 100% Factory Wired and Tested
- Available From Factory or Local Stock



**THE WATCHMAN TRADITION**  
**Watchman® Series WC™**  
**Cast Iron Receiver**  
**Single or Duplex**



**THE WATCHMAN TRADITION**  
**Watchman® Series WCS™**  
**Steel Receiver**  
**Single or Duplex**



**Series VBF™**  
**Boiler Feed Units**



**Duplex Series SCC™**  
**Condensate Units**

# Hoffman Specialty® Series Stock Units

FOR CONDENSATE RETURN & BOILER FEED APPLICATIONS



**Bell & Gossett**  
a xylem brand

# Hoffman Specialty Stock Product: The Recognized Name in Condensate Pumps

## UNIT FEATURES

**Availability:** Normally factory or locally stocked.

**Pumps:** Close-coupled centrifugal pumps with bronze impeller, bronze wearing ring, carbon /ceramic mechanical seal and stainless steel shaft.

**Float Switch:** Heavy duty, double pole, externally adjustable switches. Contacts are rated to handle 2 HP, single phase motors direct. Duplex condensate units have mechanical alternators.

**Motors:** Vertically mounted, drip proof, ball bearing design. Single phase motors through 2 HP have built in overload protection. Single phase motors are dual voltage, 115/230 volt. Three phase motors are premium efficient, dual voltage 200/208 or 230/460 volt.

**Receivers:** Condensate units feature cast iron and steel receivers. Series VBF Boiler Feed Units feature steel receivers. All cast iron receivers are warranted for 20 years from date of shipment against failure due to corrosion.

**Control Panel:** Three phase units are equipped with NEMA 2 - U.L. Listed Control Panels containing magnetic starters that re factory mounted and wired for 230 volts. Conversion kits are used to field modify for 460 volt.

---

### Series WC, WCS & SCC Condensate Units

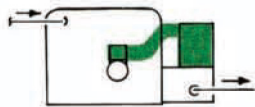

#### Operation of a condensate pump

Condensate pumps, like the Hoffman Specialty Series WC, WCS or SCC units are controlled from the water level in the receiver: as the unit fills with returning condensate, the float switch starts the pump, which simply transfers the condensate to another point in the system.

---

### Series VBF Boiler Feed Units

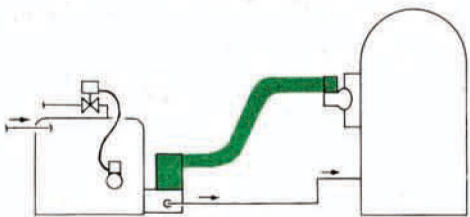

Series VBF vertical storage tank for maximum utilization of floor space

#### Operation of a boiler feed unit

A boiler feed unit like the Series VBF is controlled from the water level in the boiler that it serves, by means of a pump control mounted on the boiler. The boiler feed unit does not respond to the level in its own receiver and requires a makeup valve when insufficient condensate is present to satisfy boiler demand. An overflow opening is also required if system surges are common and boiler demand is minimum.

The boiler feed unit must absorb surges in rate of condensate return, so its receiver must be larger than that of a condensate pump. Series VBF receivers are pre-sized based on 9-10 minutes system capacity storage.

## Selection Tables

### Watchman Series WC Cast Iron Receiver Condensate Units

3500 RPM, 1 Phase 115V, Mechanical Seal, Cast Iron Receiver warranted against failure due to corrosion for 20 years from date of shipment

Model Number	System Sq. Ft. EDR	Number of Pumps	Disch. Pres. (psig)	Pump Capacity (GPM)	Receiver Capacity (Gal)	Motor HP	Accessories
WC-6-20-B	6,000	Single	22	9	6	1/3	Float switch
WC-8-20-B	8,000	Single	21	12	9	1/3	Float switch
WC-12-20-B	12,000	Single	20	18	14	1/3	Float switch
WC-12-20-B MA	12,000	Duplex	20	18	14	1/3	Mechanical alternator
WC-30-30-B MA	30,000	Duplex	30	30	23	1	Mechanical alternator

Watchman condensate units are factory wired for 115 volts and may be field converted to 230 volts 1 phase.

### Watchman Series WCS Steel Receiver Condensate Units

3500 RPM, 1 Phase 115V, Mechanical Seal, Durable, Lightweight Steel Receiver

Model Number	System Sq. Ft. EDR	Number of Pumps	Disch. Pres. (psig)	Pump Capacity (GPM)	Receiver Capacity (Gal)	Motor HP	Accessories
WCS-6-20-B	6,000	Single	22	9	6	1/3	Float switch
WCS-8-20-B	8,000	Single	21	12	9	1/3	Float switch
WCS-12-20-B	12,000	Single	20	18	14	1/3	Float switch
WCS-12-20-B MA	12,000	Duplex	20	18	14	1/3	Mechanical alternator

Watchman condensate units are factory wired for 115 volts and may be field converted to 230 volts 1 phase.

### Series SCC Condensate Units

3500 RPM, Duplex, Mechanical Seal, Durable, Cast Iron Receiver warranted against failure due to corrosion for 20 years from date of shipment

Model Number	System Sq. Ft. EDR	Disch. Pres. (psig)	Pump Capacity (GPM)	Receiver Capacity (Gal)	Motor HP	Power Supply*	Accessories
SCC1	15,000	30	15	14	3/4	1 Ph-115 or 230 Volt	Mechanical alternator
SCC2	15,000	30	15	14	3/4	3 Ph-230 or 460 Volt	Mechanical alternator Control Panel w/Magnetic starters
SCC3-A	22,000	30	22	23	3/4	3 Ph-230 or 460 Volt	Mechanical alternator Control Panel w/Magnetic starters
SCC4	45,000	30	45	36	1 1/2	3 Ph-230 or 460 Volt	Mechanical alternator Control Panel w/Magnetic starters

\*SCC1 unit is factory wired for 115 volts and may be field converted to 230 volts.

SCC2, SCC3 & SCC4 units are factory wired for 230 volts. Conversion kits must be used to field modify for 480 volt.

### Series VBF Boiler Feed Units

3500 RPM, 1 phase 115 Volt, Mechanical Seal, Vertical Steel Receiver

Model Number	System Sq. Ft. EDR	Boiler HP	Number of Pumps	Disch. Pres. (psig)	Pump Capacity (GPM)	Receiver Capacity (Gal)	Motor HP	Minute Storage (Gal)	Accessories
30VBFS 30VBFD	4,200	30	Single Duplex	20	9	30	1/3	9	All units include a water level gauge glass with shut-off valves and an internal mechanical make-up water feeder. Optional Accessories are inlet basket strainer, dial or angle thermometer, and Wall Mounted Control Panels.
50VBFS 50VBFD	7,000	50	Single Duplex	20	15	50	1/3	11	
100VBFS 100VBFD 100VBFT	13,800	100	Single Duplex Triplex	20	15	100	13	11	
200VBFS 200VBFD 200VBFT	27,800	200	Single Duplex Triplex	30	30	200	1/2	12	
200VBFS 200VBFD 200VBFT	27,800	200	Single Duplex Triplex	30	30	200	1	12	

VBF Boiler Feed Units are factory wired for 115 Volts and may be field converted to 230 volt 1 phase.

VBF pumps are controlled by level control on boiler (not supplied with unit). Consult your McDonnell & Mille Representative.

# Roughing-in-Dimensions

(All dimensions in inches)

**Caution: Do not plug or Restrict vent of overflow opening**

## Watchman Series WC Cast Iron Receiver

GAL.	A	B	C
6	8 9/16	7 1/16	6 11/16
9	10 7/8	9 3/8	9

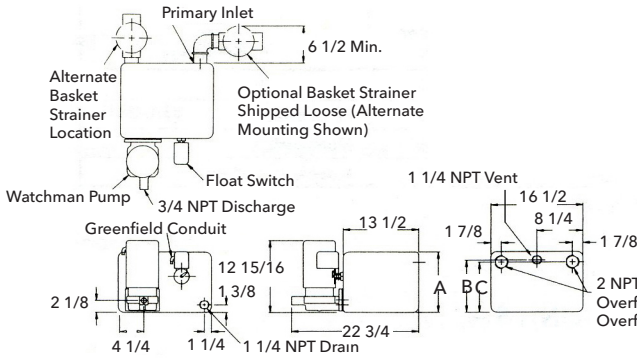

2DCC23 - WC-6-20B and WC-8-20B - 6 & 9 Gallon Receivers

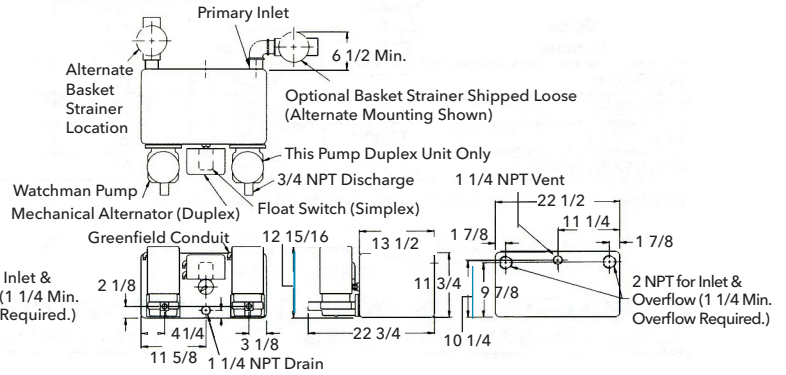

WC-12-20B and WCD-12-20B MA - 14 Gallon Receivers

## Watchman Series WCS Steel Receiver

EDR	Style	Rec. Cap	A	B	C
6,000	Single	6	8 9/16	7 1/16	6 11/16
8,000	Single	9	10 7/8	9 3/8	9

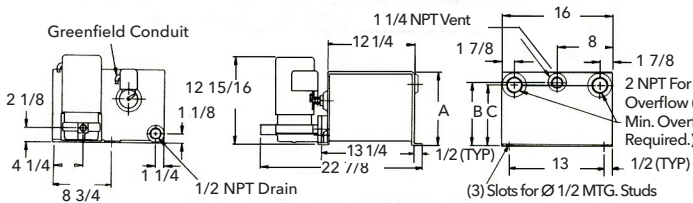

2DCC18 - 6,000 & 8,000 sq. ft. EDR Units

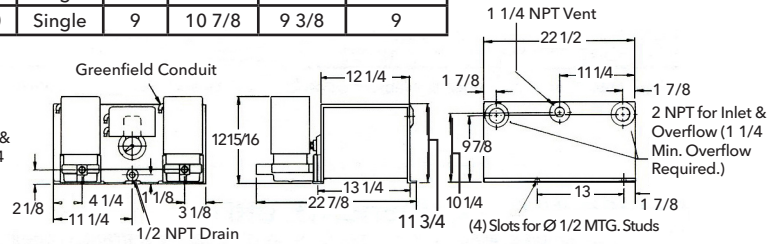

2DCC19 - 12,000 sq. ft. EDR Simplex & Duplex Units

## Series VBF Boiler Feed Units

Unit	A	B
30VBF	20 1/4	17 3/4
50VBF	30 1/4	27 3/4

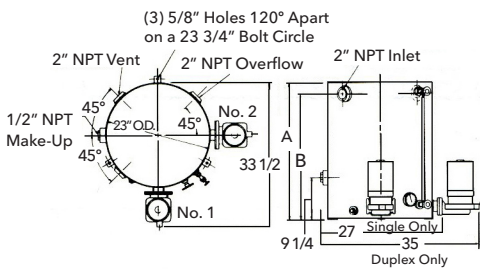

2DBF01 - 30-50 VBF Unit

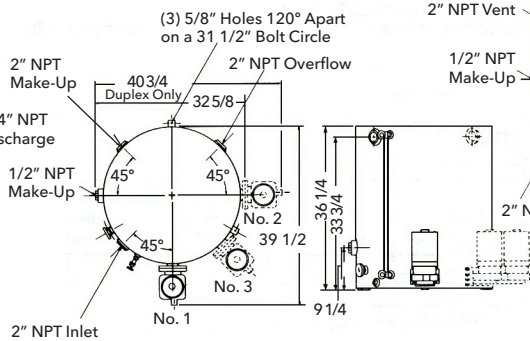

2DBF02 - 100 VBF Unit

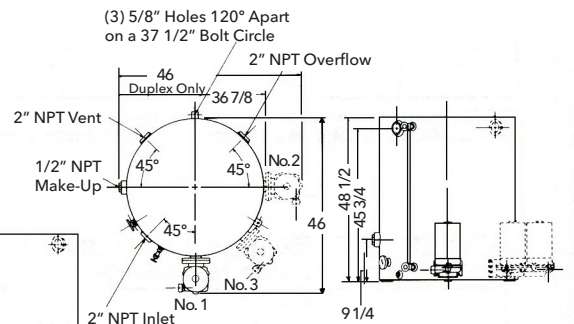

2DBF03 - 200 VBF Unit

For Series SCC Condensate Units dimensions - consult your Bell & Gossett Rep.



Xylem Inc.  
8200 N. Austin Avenue  
Morton Grove, Illinois 60053  
Phone: (847) 966-3700  
Fax: (847) 965-8379  
www.xylem.com/bellgossett