

Hoffman Specialty® Vented Condensate Units Watchman Series WC,™ WCS™ and Series SCC™

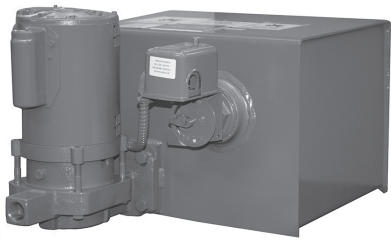

WCS Simplex
Watchman® WCS8-20B

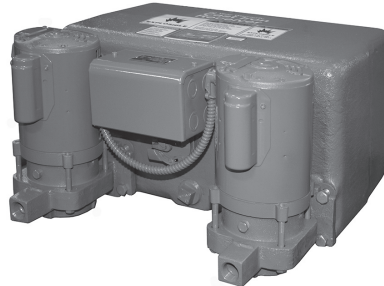

WC Duplex
Watchman® WCD-12-20BMA

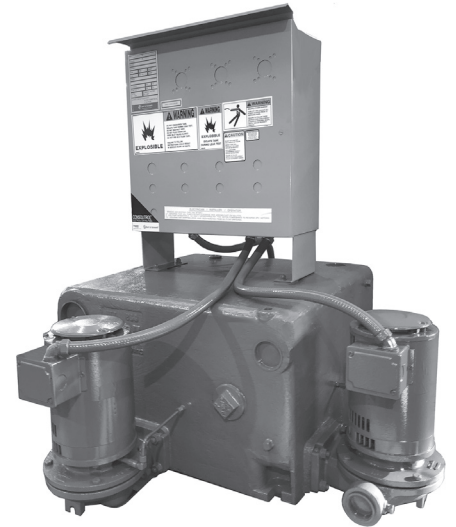

SCC4

INSTALLER: PLEASE LEAVE THIS MANUAL FOR THE OWNER'S USE.



SAFETY INSTRUCTIONS

This safety alert symbol will be used in this manual and on the unit safety instruction decals to draw attention to safety related instructions. When used, the safety alert symbol means **ATTENTION! BECOME ALERT! YOUR SAFETY IS INVOLVED! FAILURE TO FOLLOW THESE INSTRUCTIONS MAY RESULT IN A SAFETY HAZARD.**



This product can expose you to chemicals including Lead, which is known to the State of California to cause cancer and birth defects or other reproductive harm. For more information go to: www.P65Warnings.ca.gov.

If the decals as noted below are missing or are illegible contact your local B&G representative for a replacement.

1. Electrical connections to be made by qualified Electrician in accordance with all National, State and Local codes.
2. Motor must have properly sized starter with properly sized heaters to provide overload and undervoltage protection.
3. If pump, motor or piping are operating at extremely high or low temperatures, guarding or insulation is required.
4. Operating personnel should be trained in the operation of condensate return units.

CAUTION

DO NOT RUN PUMP DRY. SEAL DAMAGE MAY OCCUR. INSPECT PUMP SEAL REGULARLY FOR LEAKS, REPLACE AS REQUIRED. FOR LUBRICATION REQUIREMENTS, CONSULT SERVICE INSTRUCTIONS. FAILURE TO FOLLOW INSTRUCTIONS COULD RESULT IN INJURY OR PROPERTY DAMAGE. P70644

P70644 ALL UNITS



(2) All Units
DN0483 (Small) - DN0484 (Large)



(2) All Units
DN0485 (Small)
DN0486 (Large)

TM		
SERIES	TM	
MODEL		
SERIAL		
GPM	PSI	PUMP
CFM	IN. HG.	PUMP
DWGS		
POWER V.	PH.	HZ
CONTROL V.	PH.	HZ
TOTAL F.L. AMP.	LARGEST MOTOR F.L. AMP.	
SHORT CIRCUIT CURRENT: kA RMS SYMMETRICAL, V. MAXIMUM		
Bell & Gossett a xylem brand MORTON GROVE, ILL. U.S.A. REV. 11/11		

DN0016
SCC UNITS WITH PANEL

HOFFMAN® SERIES	
WATCHMAN® CONDENSATE UNIT	
SERIES	MODEL
SERIAL	
GPM	PSI
VOLT 115	PH 1 HZ 60
Bell & Gossett a xylem brand MORTON GROVE, ILL. U.S.A. REV. 11/11	

DN0039 ALL WC
AND WCS UNITS

INSTALLATION AND DESCRIPTION

(Vented Condensate Units)

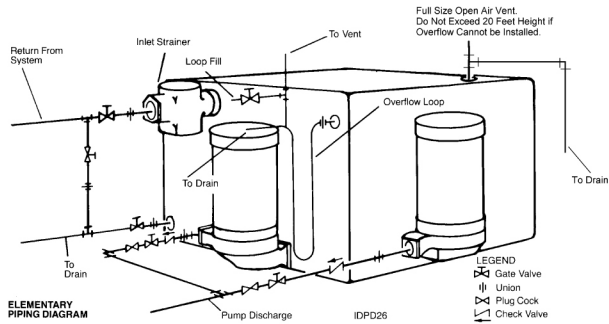

**SERIES WC AND SCC
TYPICAL DIAGRAM**
IDPD26

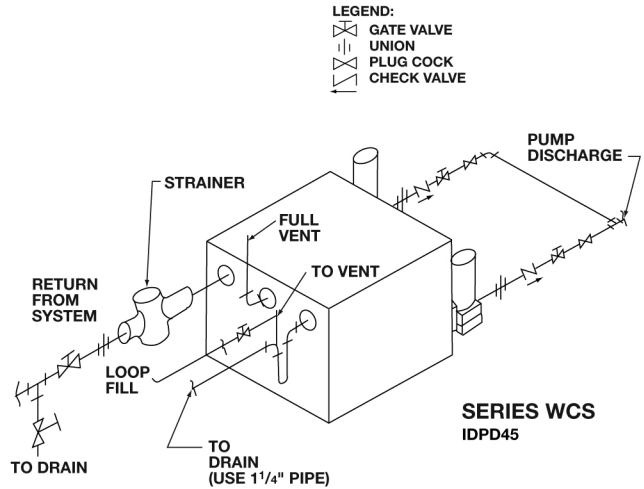

**SERIES WCS
IDPD45**

REPRESENTATIVE ELEMENTARY PIPING DIAGRAMS

DESCRIPTION

Pumps are float operated to return accumulated condensate to a boiler feed tank.

Receivers are non-code cast iron or steel.



WARNING: EXPLOSIBLE

Do not pressurize receiver. Isolate receiver during leak test. Do not plug overflow. Do not restrict vent opening to atmosphere. Open valves slowly. Failure to follow these instructions could result in serious injury or death.

PRELIMINARY INSPECTION

Assure that there is no shipping damage.

Assure that nameplate ratings agree with job specifications and actual conditions.

HANDLING

Use care in installing unit.



CAUTION: UNIT LIFTING EYE (SCC 3 & SCC 4 ONLY)

Use unit lifting eyes only to lift unit as shipped from factory. Unit must be empty and disconnected from pipes, anchors and other restraints. Use proper rigging procedures. Failure to follow these instructions could result in injury or property damage.

LOCATION

Place unit for easy access to all parts. Allow adequate space for servicing. Check ambient conditions.

NOTICE / TEMPERATURE LIMITS

Motors are designed to operate in 104°F. (40°C) max. ambient. Insulate or ventilate as required.

PIPING (General)

Pipe the unit per the Elementary Piping Diagram. Locate and support piping so as to not load the pump discharge.



CAUTION: NOT A CHEMICAL PUMP

Inject boiler feed compounds from chemical feed tank into boiler feed piping - never into condensate tank. Failure to follow these instructions could result in injury or property damage.

PIPING (Returns)

Gravity return lines from system should be properly pitched down to unit inlet. Returns must also be trapped to prevent steam entry into the unit. An inlet basket strainer is recommended. Bypass piping to a drain is recommended per the piping diagram.

PIPING (Vent)

Install a vent pipe to atmosphere. Pipe to be size of vent port on unit. Do not restrict or reduce vent opening or exceed 20 feet vertical height unless an overflow connection is provided.

PIPING (Overflow)

Pipe overflow port to drain using an overflow loop when condensate temp will exceed 200°F (93°C). Pipe to be full size of overflow port on unit except as noted above for WCS.

FLOAT SWITCHES & MECHANICAL ALTERNATORS

Floats are locked in place to prevent damage during shipment. Remove shipping locks. Check factory settings. Floats and mechanical alternators are adjustable for various levels of operation. The lead pump should start with tank 3/4 full and shut off at 2" or more above pump inlet. Lag pump should start before the tank overflows. Settings should avoid "short cycling" of the pump.

ELECTRICAL WIRING & CONTROLS

Connect power wiring per NEC. Recheck nameplate vs. specifications and conditions. All single phase motors have internal thermal protection.



WARNING: HIGH VOLTAGE ELECTRICITY

Disconnect and lock out power before connecting or servicing unit. Failure to follow these instructions could result in serious injury or death.

Three phase motors must use starters with properly sized overload relays. Overload relays furnished are designed for manual reset.

REPRESENTATIVE WIRING DIAGRAMS

WATCHMAN® SIMPLEX UNITS, SINGLE PHASE

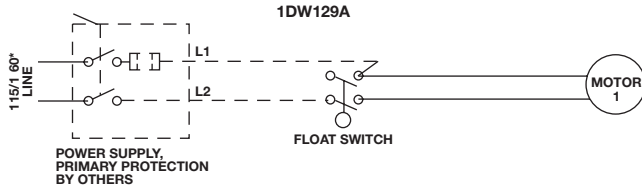

FIELD WIRING SHOULD BE IN ACCORDANCE WITH NATIONAL ELECTRIC CODE.

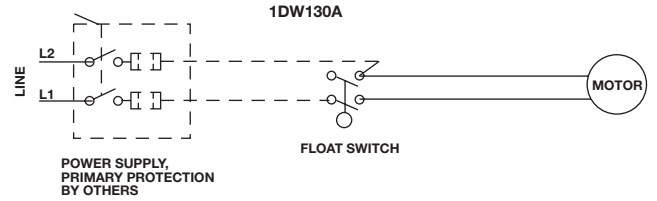

DASHED LINE WIRING & COMPONENTS BY OTHERS

WATCHMAN® AND SCC1 DUPLEX UNITS, SINGLE PHASE

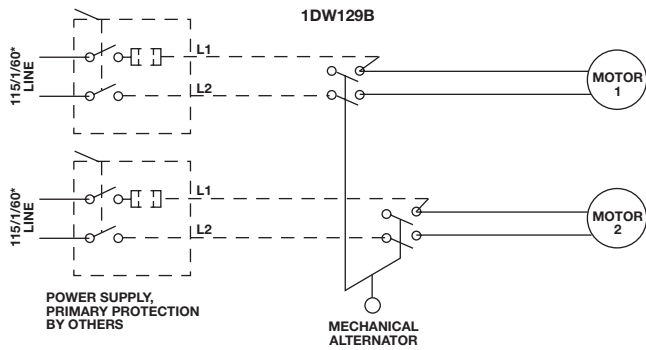

FIELD WIRING SHOULD BE IN ACCORDANCE WITH NATIONAL ELECTRIC CODE.
DASHED LINE WIRING & COMPONENTS BY OTHERS

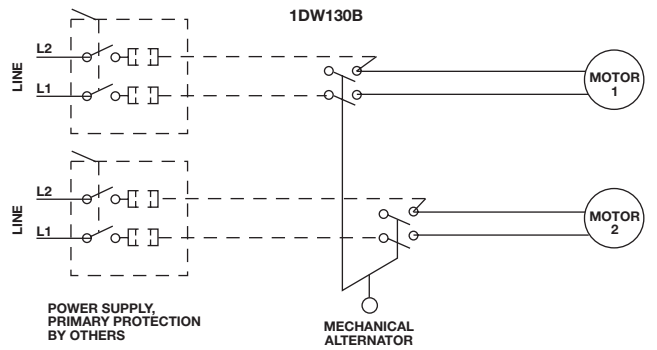

*230/1/60 VOLTAGE PERMISSIBLE IF MOTOR IS RECONNECTED PER 'HIGH VOLTAGE' DIAGRAM ON MOTOR AND APPLICABLE PRIMARY PROTECTION IS SUPPLIED.

MODEL SCC2, SCC3 & SCC4 (DUPLEX, 3 PHASE UNITS WITH CONTROL PANEL)

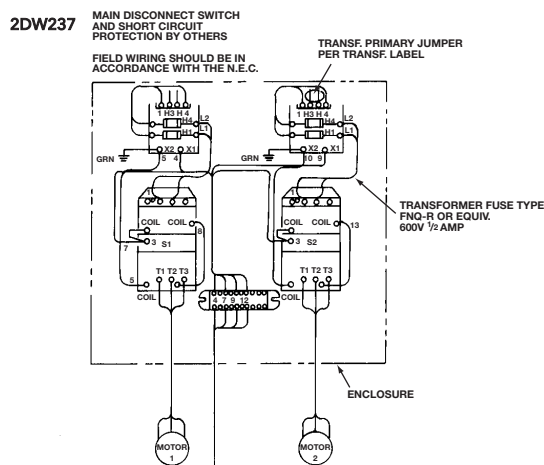

SCC2, SCC3 AND SCC4 UNITS ARE FACTORY WIRED FOR 230 VOLT, 3 PHASE 60 HERTZ. KITS ARE AVAILABLE TO CONVERT TO 460 VOLTS.

CONNECTION DIAGRAM

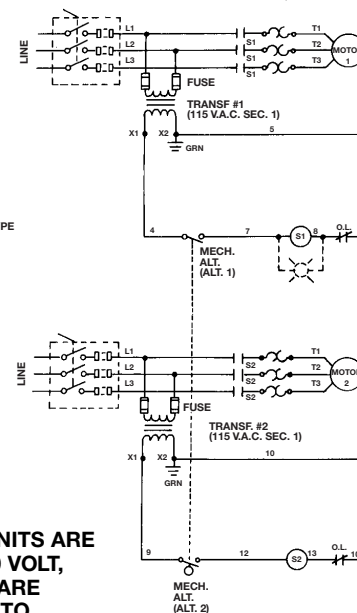

ELEMENTARY DIAGRAM

PUTTING THE UNIT INTO SERVICE

1. Assure that the unit is piped in accordance with instructions in this manual.



WARNING: EXPLOSIBLE

Do not pressurize receiver. Isolate receiver during leak test. Do not plug overflow. Do not restrict vent opening to atmosphere. Open valves slowly. Failure to follow these instructions could result in serious injury or death.

2. Isolate tank before performing any system leak test. Do not pressurize the tank as part of the leak test. Failure to do this can result in serious injury or death.
3. Check floats and alternators for free operation.



WARNING: HIGH VOLTAGE

Disconnect and lock out power before connecting or servicing unit. Failure to follow these instructions could result in serious injury or death.

4. Wire unit per National Electrical Code. See representative wiring diagrams.
5. Install drain plugs.
6. Fill receiver half full of water to prime pump(s) and prevent possible damage to pump seals. Avoid freezing conditions after unit receiver has been filled.
7. Check for proper rotation of all three phase motors. Rotation must be clockwise looking down on the motor as indicated by directional arrow on pump casting. If pump runs backwards, interchange two wires (3 phase only).



CAUTION: DO NOT REVERSE

Reverse operation can cause extensive damage to pumps. Jog the motor to test for direction of rotation. Failure to follow these instructions could result in injury or property damage.

8. Throttle plug cock in discharge line until pressure at pump (while pump is discharging) approaches pump rated pressure. Tighten plug nut to secure adjustment.



CAUTION: DO NOT RUN DRY. SEAL DAMAGE MAY OCCUR.

Inspect pump seal regularly for leaks. Replace as required. Failure to follow these instructions could result in injury or property damage.

9. Remove start-up label (below) from panel (if applicable) after complying with instructions.

ELECTRICIAN/INSTALLER/OPERATOR

- REMOVE AND DESTROY THIS TAG AFTER —
1. ASSURING THAT ALL PUMPS ROTATE CLOCKWISE PER ARROWS CAST ON VOLUTES. (JOG PUMP MOMENTARILY TO TEST — INTERCHANGE ANY TWO MOTOR POWER WIRES TO REVERSE 3PH MOTORS.)
 2. ASSURING THAT SHIPPING LOCKS HAVE BEEN REMOVED FROM ALL FLOAT SWITCHES.

10. If possible, observe operation thru several cycles.

OPERATION AND MAINTENANCE

Operators must be familiar with all sections of this manual to understand the operation of the unit.

Hot water, steam and electricity can be hazardous.



SAFETY INSTRUCTIONS

SEE COVER OF THIS MANUAL



WARNING: EXPLOSIBLE

Do not pressurize receiver. Isolate receiver during leak test. Do not plug overflow. Do not restrict vent opening to atmosphere. Open valves slowly. Failure to follow these instructions could result in serious injury or death.



WARNING: HIGH VOLTAGE

Disconnect and lock out power before connecting or servicing unit. Failure to follow these instructions could result in serious injury or death.

Check motor nameplate for any lubrication requirements. Pumps require no lubrication.

NOTICE / AUTO RESTART

Single phase motors will restart automatically after thermal overload protector trips.

Overload thermal relays in starters must be reset manually.

A properly installed unit should function unattended for long periods of time. Periodic checks to assure proper operations are highly recommended. Refer to trouble shooting section when necessary.

A variety of control options are available and are furnished in accordance with user specifications. Refer to wiring diagrams (when furnished) to determine control switch settings.

The inlet strainer (when furnished) is intended to protect the pump and system. Periodic cleaning should be included in the maintenance schedule. Check frequently in new systems.



CAUTION: SUBSEQUENT DAMAGE

A unit showing symptoms of possible problems (overflow, noise, leaks, vibrations, continual operation, etc.) must be corrected immediately. Failure to follow these instructions may result in full liability for subsequent injury or property damage.

TANK FLOAT SWITCH

INSTRUCTIONS

APPLICATION - For automatically controlling the liquid level in a closed tank by float movement.

MOUNTING - Screw-in Tank Float Switches are mounted directly to the tank by means of the 2¹/₂" I.P.S. threaded fitting (D). Before screwing this fitting into tank, loosen Nut (C) so that the fitting (D) is free to rotate in the switch bracket. Tighten the fitting (D) so that there will be no leak past the threads. Then revolve the switch case until it is horizontal and tighten Nut (C).

REVERSE ACTION - To change, relocate operating link to the opposite slot in base plate and corresponding hole in adjusting plate.

ADJUSTMENT - Switches are shipped from the factory set for a specified float travel. Reasonable adjustment of float travel can be made in the field by moving adjusting strips (7) which are held in place by Screws (A) and (B). Loosen Screw (B) and moving upper adjusting strip (7) will affect the upper limit of float travel only. Loosening Screw (A) and moving lower adjusting strip (7) will affect the lower limit of float travel.

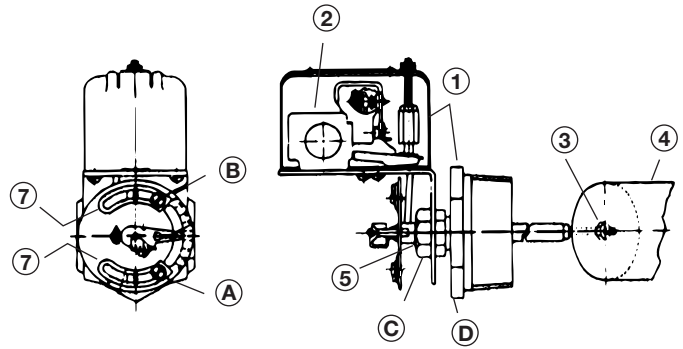

CAUTION: Switches are shipped with a bracket attached to the mounting plate. This bracket prevents the float and the rod from moving in the tank during shipment. When installing the system, this clearly marked shipping bracket must be removed and discarded.

Item Number	Description	Number Required	Part Number
1	Complete Float Switch with Float - NEMA 1	1	DA0393
4	Float	1	DA0165

MECHANICAL ALTERNATOR

INSTRUCTIONS

APPLICATION - Mechanical Alternators serve to open and close an electric circuit by an upward and downward float movement. The forces are applied by means of a float operating between different liquid levels. The action is such that two switch units are alternated on successive cycles. If the liquid level continues to rise or fall with one pump in operation, the lever will continue to travel to a further position at which point the "second" switch will be operated, throwing the stand-by pump across the line.

MOUNTING - Mechanical alternators are mounted directly to the tank by means of the 2¹/₂" I.P.S. threaded fitting (D). Before screwing this fitting into tank, loosen Nut (C) so that the fitting (D) is free to rotate in the switch bracket. Tighten the fitting (D) so that there will be no leak past the threads. Then revolve the switch case until it is horizontal and tighten Nut (C).

STANDARD OPERATION - Contacts are arranged for sump action. In this form the contacts will close on increase in liquid level.

REVERSE ACTION - To change, relocate operating link to the opposite slot in base plate and corresponding hole in adjusting plate.

ADJUSTMENT - Switches are shipped from the factory set for a specified float travel. Reasonable adjustment of float travel can be made in the field by moving adjusting strips (7) which are held in place by Screws (A) and (B). Loosen Screw (B) and moving upper adjusting strip (7) will affect the upper limit of float travel only. Loosening Screw (A) and moving lower adjusting strip (7) will affect the lower limit of float travel.

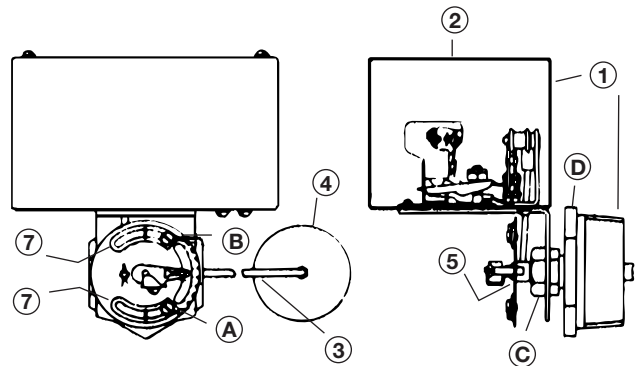

CAUTION: Switches are shipped with a bracket attached to the mounting plate. This bracket prevents the float and the rod from moving in the tank during shipment. When installing the system, this clearly marked shipping bracket must be removed and discarded.

Item Number	Description	Number Required	Part Number
1	Complete Mech. Altr. with Float - NEMA 1	1	DA0361
4	Float	1	DA0165

PUMP SERVICE INSTRUCTIONS FOR WATCHMAN “B” DESIGN CENTRIFUGAL PUMPS

These close coupled vertical centrifugal pumps are equipped with mechanical seals. If system has not been properly cleaned prior to installation of pump, foreign matter such as dirt, pipe scale, core sand, etc. may clog the impeller and damage the seal. A strainer is recommended in return line to pump. *Pump must not be operated dry.* Seals may be damaged if operated without water present.

1. Close inlet line gate valve and operate pump momentarily to remove as much liquid as possible from pump. Close discharge line gate valve.



CAUTION: HOT SURFACES

Surfaces are hot when system is in operation. Do not touch hot receiver, let unit cool before servicing. Failure to follow these instructions could result in injury or property damage.

2. Shut-off and lock out power.



WARNING: HIGH VOLTAGE

Disconnect and lock out power before connecting or servicing unit. Failure to follow these instructions could result in serious injury or death.

3. Disconnect wiring to motor.
4. Make sure unit is cool enough that pump can be handled safely. Open receiver drain to remove remaining liquid.
5. Loosen the motor to pump volute fasteners. Assure that pressure is relieved per caution note.



CAUTION: PRESSURIZED SYSTEM

Operating system may contain very hot water under pressure. Close inlet and open drains before servicing. When servicing, *loosen* screws and move components to assure pressure is relieved before *removing* screws. Keep drains open during servicing. Failure to follow these instructions could result in injury or property damage.

6. Remove four capscrews (7) holding volute to motor and lift motor and impeller out of pump volute.
7. Remove pump/motor assembly and place on work bench.
8. Hold top end of motor shaft with large screwdriver via screwdriver slot in shaft and back off impeller (counterclockwise) with a rectangular bar or other flat tool inserted between vanes of the impeller.
9. Remove the rotating part of the mechanical seal from the end of the shaft.
10. Remove seal holder (2) with stationary ceramic part of mechanical seal cup rubber from the end of the shaft.
11. Remove stationary ceramic part of mechanical seal and cup rubber from recess in seal holder.

12. To install new seal proceed as follows: Clean recess in seal holder thoroughly. Orient motor so that conduit opening on motor is to the left when looking at motor shaft. Replace seal holder on the face of the motor maintaining concentricity with motor face. Place new ceramic part of seal in the cup rubber over motor shaft and press firmly into recess of seal holder by hand, making certain both parts bottom evenly. If assembly cannot be bottomed with fingers place a wooden or cardboard tube over shaft onto ceramic and push into place. Using a clean lint-free cloth, wipe the mating surfaces of the seal clean of any foreign matter. Moisten the carbon section of the rotating part of the seal and place onto the shaft to seat against ceramic. Place seal spring onto shaft.

13. Hold motor shaft as described in #4 and replace the impeller on the shaft (clockwise rotation) making sure it is tight.

14. Orient motor for pump reassembly with conduit opening to the left. When mounting pump case, discharge should be 90° to the right of the conduit opening on motor. Use care to insure tight gasket fit to prevent water leakage.

15. Replace four capscrews (7). Tighten down capscrews evenly to avoid damage.

16. Reconnect pump bleed line (where applicable) and motor wiring.



CAUTION: DO NOT RUN DRY. SEAL DAMAGE MAY OCCUR.

Inspect pump seal regularly for leaks. Replace as required. Failure to follow these instructions could result in injury or property damage.

17. Close drain and slowly open inlet valves. See warning.



WARNING: EXPLOSIBLE

Do not pressurize receiver. Isolate receiver during leak test. Do not plug overflow. Do not restrict vent opening to atmosphere. Open valves slowly. Failure to follow these instructions could result in serious injury or death.

18. Jog to check motor rotation. See caution.



CAUTION: DO NOT REVERSE

Reverse operation can cause extensive damage to pumps. Jog the motor to test for direction of rotation. Failure to follow these instructions could result in injury or property damage.

19. Observe operation thru several cycles.

WATCHMAN "B" DESIGN (FULL MOTOR) PUMP PARTS LIST

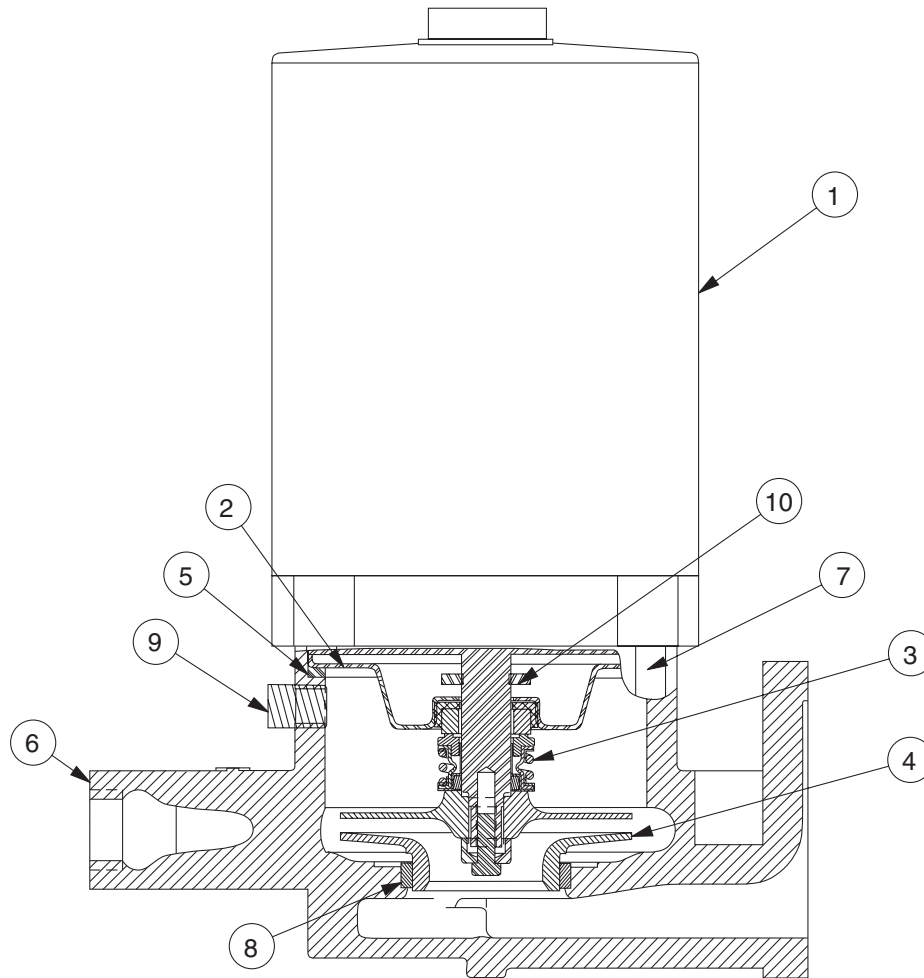

ITEM NUMBER	DESCRIPTION	NUMBER REQUIRED	PART NUMBER
1	Motor 1/3 hp. 1ph, 3500 rpm	1	DM0005
2	Seal Holder	1	DP1966
3	Seal*	1	-
4	Impeller	1	DP0321
5	Head Gasket*	1	DG0092
6	Pump Case with Wearing Ring	1	DP1665
7	Capscrew	4	DJ0083
8	Wear Ring	1	DP0482
9	Pipe Plug 1/4"	1	P39040
10	Water Slinger	1	DP0848
*	Seal Kit including Mechanical Seal, Head Gasket & Case to Receiver Gasket	1	180013
	Complete Pump and Motor Assembly	1	180001

Order Replacement Parts by Description and Part No.
Specify Serial No. shown on nameplate.

INSTRUCTIONS FOR THE REPLACEMENT OF MECHANICAL SEALS ON “WATCHMAN” UNIT WITH “A” DESIGN PUMP & MOTOR ASSEMBLIES

These close coupled vertical centrifugal pumps are equipped with mechanical seals. If system has not been properly cleaned prior to installation of pump, foreign matter such as dirt, pipe scale, core sand, etc. may clog the impeller and damage the seal. A strainer is recommended in return line to pump. *Pump must not be operated dry.* Seals may be damaged if operated without water present.

1. Close inlet line gate valve and operate pump momentarily to remove as much liquid as possible from pump. Close discharge line gate valve.



CAUTION: HOT SURFACES

Surfaces are hot when system is in operation. Do not touch hot receiver, let unit cool before servicing. Failure to follow these instructions could result in injury or property damage.

2. Shut-off and lock out power.



WARNING: HIGH VOLTAGE

Disconnect and lock out power before connecting or servicing unit. Failure to follow these instructions could result in serious injury or death.

3. Disconnect wiring to motor.
4. Make sure unit is cool enough that pump can be handled safely. Open receiver drain to remove remaining liquid.
5. Loosen the motor to pump volute fasteners. Assure that pressure is relieved per caution note.



CAUTION: PRESSURIZED SYSTEM

Operating system may contain very hot water under pressure. Close inlet and open drains before servicing. When servicing, *loosen* screws and move components to assure pressure is relieved before *removing* screws. Keep drains open during servicing. Failure to follow these instructions could result in injury or property damage.

6. Remove three capscrews holding pump head to pump case and lift motor, pump head and impeller out of pump case.
7. Hold top end of motor shaft with large screwdriver or screwdriver socket and back off impeller (counterclockwise) with a rectangular bar or other flat tool inserted between vanes of the impeller.
8. Remove the rotating part of the mechanical seal from the end of the shaft.
9. Remove the four thru-bolts holding motor end bell and stator to pump head, and mark end bell, stator, and pump head for proper orientation later.
10. Remove pump head and rotor assembly from stator being careful to keep all Belleville washers or finger springs properly oriented in space above top motor bearing. (On A. O. Smith motor, rotor will stay with stator and washers are in lower end of bell.)
11. Remove rotor and lower bearing from pump head. Remove water slinger from slot in pump head.
12. Remove stationary ceramic part of mechanical seal and cup rubber from recess in pump head.

13. To install new seal proceed as follows: Clean recess in pump head thoroughly. Coat recess and outer edge of new cup rubber with grease. Place new ceramic part of seal in the cup rubber and press firmly into recess by hand, making certain both parts bottom evenly. If assembly cannot be bottomed with fingers place cardboard disc on ceramic and force into place with flat tool.
14. Regrease upper motor bearing with Chevron BRB greases or equal.
15. Reassemble rotor into pump head and being careful not to chip or damage ceramic part of seal. Water slinger must be slipped into recess in head before assembling. A thin coating of oil or grease on inside edge of hole in slinger will cause the slinger to slip easily over end of rotor shaft.
16. With the motor vertical, top end bell down, and with Belleville washers or finger springs properly oriented in the top end bell recess, lower the rotor and head assembly as a unit, holding it by rotor shaft.
17. Orient the pump head properly and install the thru-bolts.
18. Place motor vertically with pump end up. Do not attempt assembly of the head and impeller with shaft horizontal.
19. The carbon (rotating) part of the seal should not be loose. If it is, hold it in place with small amount of grease. Using a clean, lint-free cloth, wipe the mating surfaces perfectly clean. Grease rubber lightly and push seal onto shaft so that the carbon will contact the ceramic seat.
20. Replace the impeller on the shaft (clockwise rotation), making sure it is tight.
21. Reassemble the unit in reverse order (step 3 thru 1) when assembling the pump. Use care to insure tight gasket to prevent water leakage. A new gasket should be ordered with replacement seal.



CAUTION: DO NOT RUN DRY. SEAL DAMAGE MAY OCCUR.

Inspect pump seal regularly for leaks. Replace as required. Failure to follow these instructions could result in injury or property damage.

22. Close drain and slowly open inlet valves. See warning.
23. Be sure there is adequate water in receiver before operating pump. Allow short period of operation to clear up occasional slight leakage as seal surfaces adjust themselves.



WARNING: EXPLOSIBLE

Do not pressurize receiver. Isolate receiver during leak test. Do not plug overflow. Do not restrict vent opening to atmosphere. Open valves slowly. Failure to follow these instructions could result in serious injury or death.

24. Jog to check motor rotation. See caution.



CAUTION: DO NOT REVERSE

Reverse operation can cause extensive damage to pumps. Jog the motor to test for direction of rotation. Failure to follow these instructions could result in injury or property damage.

25. Observe operation thru several cycles.

WATCHMAN "A" DESIGN PUMP AND MOTOR ASSEMBLY

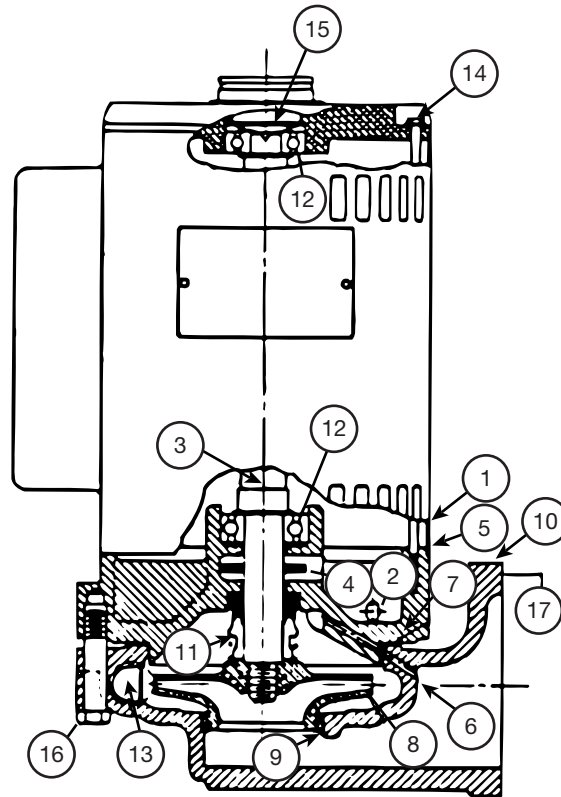

ITEM NUMBER	DESCRIPTION	NUMBER REQUIRED	PART NUMBER
1-5	Motor with Pump Head	1	180061
4	Water Slinger	1	DP0848
5	Pump Head	1	DP0206
7	Head Gasket	1	DG0134
8	Impeller	1	DP0321
9	Case Wearing Ring	1	DP0482
9-10	Pump Case with Wearing Ring	1	DP1602
16	Head to Case Capscrews	3	DJ0077
17	Case to Receiver Gasket	1	DG0060
	Seal Kit including Mechanical Seal, Head Gasket & Case to Receiver Gasket	1	180013
	Complete Pump and Motor Assembly	1	180060

Order Replacement Parts by Description and Part No.
Specify Serial No. shown on nameplate.

PUMP SERVICE INSTRUCTIONS FOR CENTRIFUGAL PUMPS (Other Than “Watchman®” Pumps)

Vertical mounting puts motor above floor dirt and water

Close coupled centrifugal pumps are designed for years of trouble free service. Units have mechanical shafts seals.

1. Close inlet gate valve and operate pump momentarily to remove as much liquid as possible from pump. Close discharge line gate valve.



CAUTION: HOT SURFACES

Surfaces are hot when system is in operation. Do not touch hot receiver, let unit cool before servicing. Failure to follow these instructions could result in serious injury or death.

2. Shut-off and lock out power.



WARNING: HIGH VOLTAGE

Disconnect and lock out power before connecting or servicing unit. Failure to follow these instructions could result in serious injury or death.

3. Make sure unit is cool enough that pump can be handled safely. Open drain to remove remaining liquid.
4. Carefully remove pump drain plug and bleed line. Wait for complete drainage.
5. Loosen the motor bracket to pump volute capscrews. Assure that pressure is relieved per caution note.



CAUTION: PRESSURIZED SYSTEM

Operating system may contain very hot water under pressure. Close inlet and open drains before servicing. When servicing, *loosen* screws and move components to assure pressure is relieved before *removing* screws. Keep drains open during servicing. Failure to follow these instructions could result in injury or property damage.

6. Complete the removal of the above hardware. Remove pump/motor assembly and place on work bench.
7. Remove self locking stainless steel capscrews and stainless steel washer (or self locking brass cap nut and washer) that secure the impeller in place.
8. To remove impeller from motor shaft proceed as follows:
 - (1) Keyed Shafts. Remove impeller with gear puller or other means which will not damage impeller or bend motor shaft.
 - (2) Threaded Shafts. Hold end of motor shaft opposite pump with large screwdriver or other suitable tool and back impeller off with a rectangular bar or other flat tool inserted between the vanes of the impeller.
9. Remove rotating part of seal from shaft, being careful not to break carbon face.
10. Remove capscrews holding motor bracket to motor and remove bracket.

11. Remove stationary part of seal assembly, being careful not to chip or break ceramic seal.

12. To install seal proceed as follows:

- (1) Clean recess in bracket thoroughly. Coat recess and “rubber” portion of seat with soap solution. Press seat into recess firmly by hand making certain both parts bottom evenly. If seal cannot be bottomed with fingers place cardboard shipping disc on ceramic and force into place with tool.
- (2) Carefully place bracket in position on motor shaft without displacing ceramic seat and secure bracket to motor with capscrews.
- (3) Place motor vertically with pump end up. Do not attempt assembly of seal and impeller with shaft horizontal.
- (4) The “carbon” of rotating part of seal should not be loose. If it is, hold in place with grease. Using clean, lint-free cloth, wipe mating surfaces perfectly clean. Soap shaft and push seal onto shaft so that carbon will contact ceramic seal. If spacer is required, use grease to cause spacer to adhere to bottom of seal after seal has been put on shaft. Be sure spacer is on larger diameter of shaft so that it will not catch between shoulder and impeller.

13. Replace impeller on shaft. Replace stainless steel washer and secure impeller with capscrew or cap nut.

14. Place new gasket on pump volute and reassemble motor and pump subassembly on pump volute.

15. Reconnect pump bleed line and motor wiring.



CAUTION: DO NOT RUN DRY. SEAL DAMAGE MAY OCCUR.

Inspect pump seal regularly for leaks. Replace as required. Failure to follow these instructions could result in injury or property damage.

16. Close drain and slowly open inlet valves. See warning.



WARNING: EXPLOSIBLE

Do not pressurize receiver. Isolate receiver during leak test. Do not plug overflow. Do not restrict vent opening to atmosphere. Open valves slowly. Failure to follow these instructions could result in serious injury or death.

17. Jog to check motor rotation. See caution.



CAUTION: DO NOT REVERSE

Reverse operation can cause extensive damage to pumps. Jog the motor to test for direction of rotation. Failure to follow these instructions could result in injury or property damage.

18. Observe operation thru several cycles.

616PF PUMP USED ON SCC

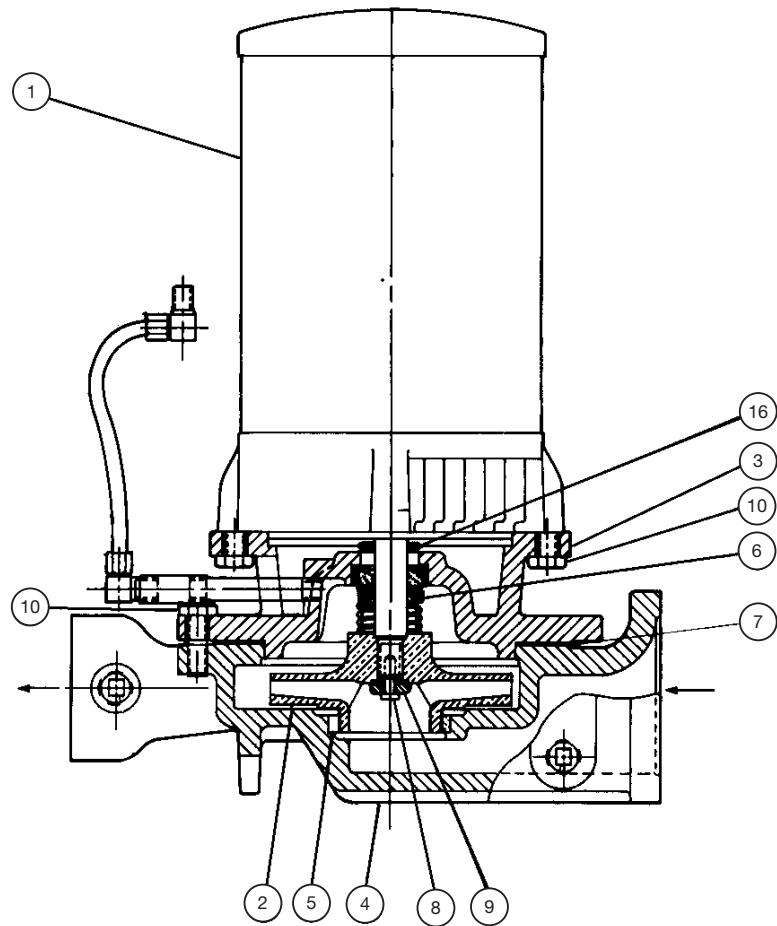

ITEM NUMBER	DESCRIPTION	NUMBER REQUIRED	PART NUMBER
1	Motor - Order by Description	1	Consult Factory
2	Impeller	1	Consult Factory
3	Pump Head	1	DP0208
4	Case with Wear Ring	1	DP1603
5	Wearing Ring	1	DP0482
8	Impeller Capscrew	1	DJ0213
9	Impeller Washer	1	DJ0267
10	Capscrews	8	DJ0066
16	Water Slinger	1	DP0848
6-7	Seal Kit including Mechanical Seal, Head Gasket	1	180014
	Case to Receiver Gasket	1	DG0060

Order Replacement Parts by Description and Part No.
Specify Serial No. shown on nameplate.

TROUBLE SHOOTING PROCEDURE

All units are thoroughly tested at the factory before shipment. They should operate satisfactorily without further adjustment if properly installed and providing they have not been damaged by rough handling in transit. If system or unit performance is not satisfactory, refer to the following check list.

Pump Will Not Start

1. The power supply has been interrupted, disconnect switch is open, or selector switch is improperly positioned.
2. Incorrect voltage for motor. Check voltage and wiring with motor characteristics.
3. Incorrect starter coil for power supply.
4. The overload relays and the starter have tripped out and must be reset. Ambient temperature may be too high.
5. Check pump controls or other controls for proper operation.
6. Wiring to control cabinet is incorrect or connections are loose.
7. The strainer is dirty thus retarding flow. Clean periodically.

Pump Runs Continuously

1. Pump is running backward. Rotation of three phase motors may be corrected by interchanging any two of the three wires. Rotation should be clockwise looking down on motor.
2. Steam traps are blowing through causing condensate to return at excessive temperatures. This may reduce the capacity of pump below its rating, depending on the unit and type of pump furnished. Traps should be repaired or replaced.
3. The total required pressure at the pump discharge is greater than the pressure for which the pump was designed. Check the total pressure which includes atmospheric pressure, the friction head and the static head.

4. A valve in the discharge line is closed or throttled too tightly. Check valve is installed backwards.
5. The impeller eye is clogged.
6. Pump is too small for system.

Condensate Pump is Noisy

1. The pump is working against a lower pressure than designed for. While pump is discharging, adjust plug cock in discharge line until pressure at pump approaches pump rated pressure.
2. Excessive condensate temperature. Correct system conditions. However, this applies to certain units only; others are designed to handle boiling water.
3. Magnetic hum or bearing noise in motor. Consult motor manufacturer's authorized service station nearest unit location.
4. Starter chatters. Trouble is caused by low line voltage, poor connections, defective starter coil, or burned contacts.
5. Pump is running backward.

The System is Noisy

1. Banging in steam mains is usually caused by steam "imploding" in condensate lying in low points in lines. These problems can be eliminated by dripping low points, properly supporting the pipe, or by increasing the pitch of the lines.
2. Improper dripping of the steam mains and risers; where there is a rise in the steam main, or where it branches off into a riser, a drip trap must be installed in the drain line.
3. The piping is too small to drain properly.
4. A defective trap is holding condensate in steam supply line.

DEALER SERVICING

If trouble occurs that cannot be rectified, contact your local B&G representative. He will need the following information in order to give you assistance.

1. Complete nameplate data of pump and motor.
SEE RATING NAMEPLATE.
2. Suction and discharge pipe pressure gauge readings.
3. Ampere draw of the motor.
4. A sketch of the pump hook-up and piping.

HOFFMAN [®]		SERIES	
WATCHMAN [®]		CONDENSATE UNIT	
SERIES	™	MODEL	
SERIAL			
GPM		PSI	
VOLT 115		PH 1	HZ 60
DN0039		Bell & Gossett	REV#8
	a xylem brand	MORTON GROVE, IL U.S.A.	
		ASSEMBLED IN U.S.A.	

xylem
Let's Solve Water

Xylem Inc.
8200 N. Austin Avenue
Morton Grove, Illinois 60053
Phone: (847) 966-3700
Fax: (847) 965-8379
www.xylem.com/bellgossett

Bell & Gossett is a trademark of Xylem Inc. or one of its subsidiaries.
© 2020 Xylem Inc. DN01561 March 2020