

# Manual Balancing Valve

Variable Orifice • Globe Valve • Memory Stop • 230 WOG

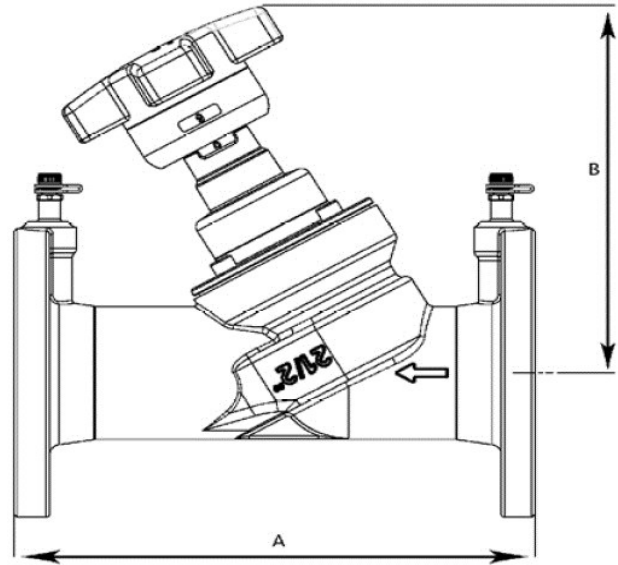

**Terminator GV**



## Features

- Accurate and precise flow measurement and balancing
- Positive shut-off
- "Y" pattern globe style design
- Multi-turn, 360° handwheel with vernier scale and digital readout
- Built in memory stop
- Offset pressure/temperature ports

## Pressure / Temperature Rating

- 230 WOG
- 14°F -248°F

## Material Specifications

Part	Material
Body	Cast Iron
End Connections	ANSI 125 Flanged
Gaskets	EPDM
Seat Seal	PTFE
Handwheel	Polyamide Plastic

## Dimensions

Part Number	Size	A	B	Minimum Flow	Nominal Flow	Maximum Flow
TGV-GFF	2-1/2"	11.42	8.94	2.13	33-100	318.30
TGV-HFF	3"	12.20	9.5	4.19	100-117	374.50
TGV-IFF	4"	13.78	10.20	6.09	117-200	646.80
TGV-KFF	6"	18.90	12.05	13.70	320-440	1447.00
TGV-LFF	8"	23.60	13.50	30.00	450-750	2415
TGV-MFF	10"	28.70	16.00	47.00	750-1300	4050
TGV-NFF	12"	33.50	19.00	43.00	1300-1600	5115



**WARNING:** This product can expose you to chemicals including lead, which is known to the State of California to cause cancer, and lead, which is known to the State of California to cause birth defects or other reproductive harm. For more information go to [www.P65Warnings.ca.gov](http://www.P65Warnings.ca.gov).

# Manual Balancing Valve

Variable Orifice, Globe Valve, Memory Stop, 300 WOG

## Series TGV 2.50" - 6.00"

This diagram details the relationship between flow, pressure drop and valve preset points. Use the diagram to select the correct valve size and corresponding handwheel setting to fulfill the application requirements.

Determine the required flow in the circuit (A) and the pressure drop (B). Draw a line between these two values. Read off the corresponding Cv value on the Cv scale.

Determine the valve setting, in handwheel turns, by drawing a horizontal line (D) from the intersection point on the Cv scale to the corresponding valve setting position.

For the highest level of accuracy, it is recommended to choose a valve that has at least 3 open turns.

**Example:** A 4" valve is required to be open 7.5 turns for a Cv value of 160 at a flow rate of 150 gpm and a pressure drop of 2ft.

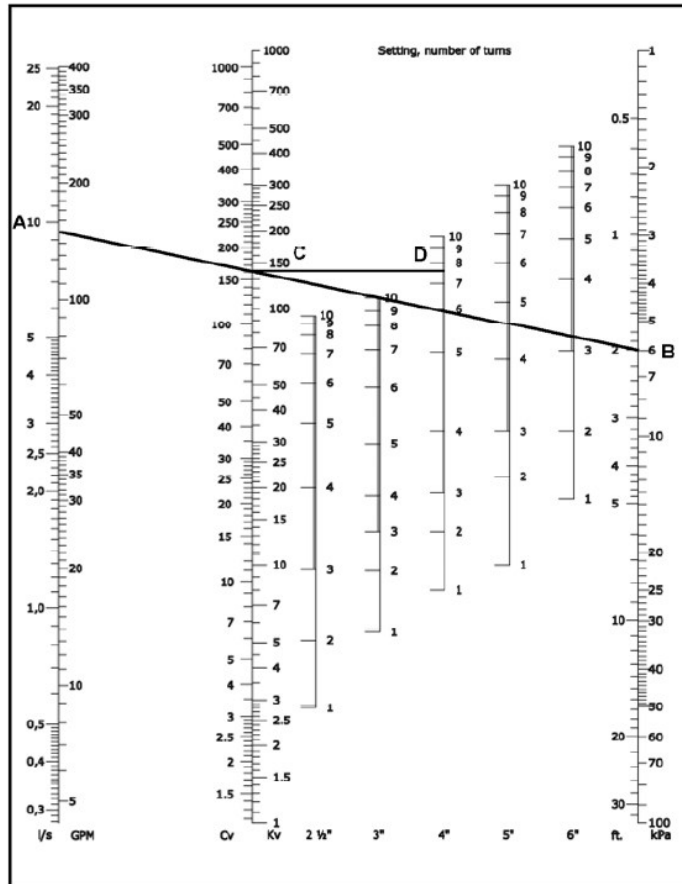

### Cv Values

Flow coefficient values (Cv's) at various handwheel settings	Handwheel Setting					
Setting	2-1/2"	3"	4"	5"	6"	
	DN 65	DN 80	DN 100	DN 125	DN 150	
1	3.20	6.40	9.30	11.60	20.90	
1.5	4.60	8.70	12.80	19.70	29.00	
2	5.90	11.00	15.70	25.50	38.30	
2.5	8.50	13.30	19.10	30.20	53.40	
3	11.10	15.70	22.00	38.30	78.90	
3.2	13.10	16.60	23.80	42.90	90.50	
3.4	15.10	17.50	25.50	48.70	103	
3.6	17.40	18.60	29.00	55.70	118	
3.8	20.30	19.70	33.60	63.80	135	
4	23.20	21.50	38.30	73.10	151	
4.2	26.80	23.20	45.20	82.40	164	
4.4	30.40	24.90	53.40	91.60	176	
4.6	34.00	27.30	61.50	102	189	
4.8	37.60	30.70	69.60	113	202	
5	41.20	34.20	77.70	123	216	
5.2	44.80	38.30	85.80	135	231	
5.4	48.40	42.90	94.00	146	246	
5.6	52.00	47.60	102	157	260	
5.8	55.60	52.20	109	166	273	
6	59.20	56.80	115	174	285	
6.2	62.80	61.50	122	183	298	
6.4	66.10	66.10	129	194	311	
6.6	69.60	70.80	135	204	322	
6.8	73.10	75.40	140	215	332	
7	76.60	79.50	145	225	341	
7.2	80.00	83.50	151	235	351	
7.4	82.90	87.60	157	246	363	
7.6	85.80	91.60	162	255	374	
7.8	88.70	95.10	168	264	384	
8	91.10	98.60	174	274	394	
8.2	93.40	102	180	283	406	
8.4	95.70	105	186	292	418	
8.6	97.40	108	190	302	428	
8.8	99.20	111	194	310	437	
9	101	114	197	317	447	
9.2	103	116	202	324	456	
9.4	104	119	206	331	465	
9.6	106	123	211	338	474	
9.8	107	125	216	343	484	
10	108*	128*	220*	349*	493*	

\* Valve is fully open

### Installation Recommendations

Install the valve in the correct flow direction according to the arrow on the valve body and the distance parameters detailed in Figure 1 (Note: D = pipe diameter).

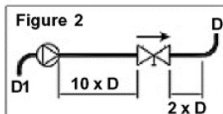
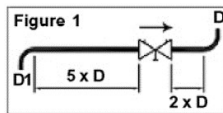

When used with a pump, it is recommended to use a straight length of pipe totaling 10 x D (instead of 5 x D) upstream or downstream to avoid turbulence that will affect the measuring accuracy. See Figure 2.

Turbulence can influence the measurements by up to 20% if this recommendation is not followed.

### Flow Measurement & Accuracy

determined using the pressure drop diagram that is included in the operating instructions with each HCI Balancing valve.

The accuracy is highest when the valve is fully open. Therefore, it is recommended to choose a valve that can be opened at least three turns at the calculated pre-setting value. Figure 3 represents the flow measurement deviation in relation to handwheel turns.

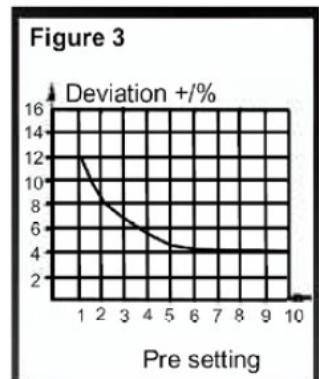

### Correction for Liquids

Applies to liquids other than water. Correct the measured flow (q) by the density (γ) according to this formula. See Figure 4

Figure 4  
**Actual Flow** =  $\frac{q_{CBI}}{\sqrt{\gamma}}$

### Sizing a Balancing Valve

When the differential pressure and design flow are known, use this formula to calculate Cv value. See Figure 5

Figure 5  
 $C_v = 1.52 \frac{q}{\sqrt{\Delta p}}$   
q in GPM, Δp in Ft. of H2O  
 $C_v = \frac{q}{\sqrt{\Delta p}}$   
q in GPM, √p in PSI