

TECHNICAL BROCHURE

B2WD-3WD R2



FEATURES

Impeller: Cast iron, semi-open or enclosed, non-clog, dynamically balanced with pump out vanes for mechanical seal protection. Optional silicon bronze impeller available.

Casing: Cast iron flanged volute type for maximum efficiency. Designed for easy installation on A10-20 guide rail.

Dual Mechanical Seals

- **Lower:** SILICON CARBIDE VS. SILICON CARBIDE sealing faces for superior abrasive resistance, stainless steel metal parts, BUNA-N elastomers.
- **Upper:** CARBON VS. CERAMIC sealing faces, stainless steel metal parts, BUNA-N elastomers.

Seal Sensor Probe: Located in oil-filled chamber. If pumpage should begin to leak past lower seal it indicates to pump control panel a fault has occurred. Requires optional Seal Fail Circuit in the control panel.

Shaft: Corrosion resistant, 400 stainless steel. Threaded design. Locknut on all models to guard against component damage on accidental reverse rotation.

Fasteners: 300 series stainless steel.

Capable of running dry without damage to components.

Designed for continuous operation when fully submerged.

AGENCY LISTINGS



Tested to UL 778 and CSA 22.2 108 Standards
By Canadian Standards Association
File #LR38549

2WD/3WD

SUBMERSIBLE 2" NON-CLOG SEWAGE PUMP

DUAL SEAL WITH SEAL SENSOR PROBE



APPLICATIONS

Specifically designed for the following uses:

- Sewage systems
- Dewatering/Effluent
- Water transfer
- Light industrial
- Commercial applications

Anywhere waste or drainage must be disposed of quickly, quietly and efficiently.

SPECIFICATIONS

Pump:

- Solids handling capabilities: 2" maximum.
- Capacities: up to 183 GPM.
- Total heads: up to 52' TDH.
- Discharge size: 2" NPT threaded companion flange on 2WD. 3" NPT threaded companion flange on 3WD.
- Temperature: 104° F (40° C) continuous, 140° F (60° C) intermittent.

NOMENCLATURE DESCRIPTION

1st Character - Discharge Size

2 = 2" discharge 3 = 3" discharge

2nd and 3rd Characters - Series/Solids Size

WD = wastewater, 2" solids handling, dual seal with seal fail probe in pump.

4th Character - Mechanical Seals

5 = silicon carbide/silicon carbide/BUNA - lower seal and carbon/ceramic/BUNA - upper seal (standard)
 3 = silicon carbide/tungsten carbide/BUNA - lower seal and carbon/ceramic/BUNA - upper seal (optional)

5th Character - Cycle/RPM

1 = 60 Hz/3500 RPM 5 = 50 Hz/2900 RPM
 2 = 60 Hz/1750 RPM 6 = 50 Hz/1450 RPM

6th Character - Horsepower

B = 1/3 HP D = 3/4 HP
 C = 1/2 HP E = 1 HP

MOTORS

- Fully submerged in high grade turbine oil for lubrication and efficient heat transfer. All ratings are within the working limits of the motor.
- Class F insulation

Single phase (60 Hz):

- All single phase models feature capacitor start motors for maximum starting torque.
- Built-in overload with automatic reset.
- 1/3 and 1/2 HP - 16/3 SJTOW with 115 V or 230 V three prong plug.
- 3/4 and 1 HP - 14/3 STOW with bare leads.

Three phase (60 Hz):

- Overload protection must be provided in starter unit.
- 1/2-1 HP - 14/4 STOW with bare leads.
- Designed for Continuous Operation: Pump ratings are within the motor manufacturer's recommended working limits, can be operated continuously without damage when fully submerged.
- Bearings: Upper and lower heavy duty ball bearing construction.
- Power and Control Cable: Severe duty rated, oil and water resistant. Epoxy seal on motor end provides secondary moisture barrier in case of outer jacket damage and to prevent oil wicking. 20 foot standard with optional lengths available.

7th Character - Phase/Voltage/Enclosure

0 = single phase, 115 V 4 = three phase, 460 V
 1 = single phase, 230 V 5 = three phase, 575 V
 2 = three phase, 200 V 8 = single phase, 208 V
 3 = three phase, 230 V 9 = single phase, 220 V, 50 Hz

8th Character - Impeller Diameter

A = 3.75" 1 HP 3500 RPM E = 4.69" 1/3 HP 1750 RPM
 B = 5.75" 1 HP 1750 RPM H = 3.44" 3/4 HP 3500 RPM
 C = 5.38" 3/4 HP 1750 RPM J = 3.19" 1/2 HP 3500 RPM
 D = 5.00" 1/2 HP 1750 RPM K = 2.94" 1/3 HP 3500 RPM

9th Character - Cord Length (Power and Sensor)

A = 20' (standard) F = 50'
 D = 30' J = 100'

10th Character - Options

B = Bronze impeller E = Epoxy paint
 F = Both epoxy paint and bronze impeller

Last Character - Option

H = Pilot duty thermal sensors (3 phase only!!)

MODEL AND MOTOR INFORMATION

Order No.	HP	Phase	Volts	RPM	Impeller		Maximum Amps	L.R. Amps	KVA Code	F.L. Motor Efficiency %	Resistance		Wt. (lbs.)					
					Dia. (in.)	Code					Start	Line-Line						
2WD52B0EA	0.33	1	115	1750	4.69	E	10.7	30.0	M	54	11.9	1.7	90					
2WD52B8EA			208				6.8	19.5	K	51	9.1	4.2						
2WD52B1EA			230				4.9	14.1	L	53	14.5	8.0						
2WD52C0DA	0.5	1	115	1750	5.00	D	14.5	31.1	J	55	9.3	1.4	94					
2WD52C8DA			208				8.0	19.5	K	51	9.1	4.2						
2WD52C1DA			230				7.3	16.5	J	54	11.7	5.6						
2WD52C2DA		3	200				3.8	12.3	K	75	NA	6.7						
2WD52C3DA			230				3.3	9.7	K	75	NA	9.9						
2WD52C4DA			460				1.7	4.9	K	75	NA	39.4						
2WD52C5DA		575	1.4				4.3	K	68	NA	47.8							
2WD52D8CA		0.75	1				208	1750	5.38	C	11.0	39.0		K	65	2.6	1.4	98
2WD52D1CA							230				9.4	24.8		J	57	4.8	2.3	
2WD52D2CA	3		200	4.1	21.2	H	74				NA	4.3						
2WD52D3CA			230	3.6	17.3	J	76				NA	5.6						
2WD52D4CA			460	1.8	8.9	J	76				NA	22.4						
2WD52D5CA	575		1.5	7.3	J	71	NA				29.2							
2WD52E8BA	1		1	208	1750	5.75	B				14.0	39.0	K	65	2.6	1.4	104	
2WD52E1BA		230		12.3				30.5	H	60	4.3	1.8						
2WD52E2BA		3	200	6.0				21.2	H	74	NA	4.3						
2WD52E3BA			230	5.8				17.3	J	76	NA	5.6						
2WD52E4BA			460	2.9				8.9	J	76	NA	22.4						
2WD52E5BA		575	2.4	7.3				J	71	NA	29.2							
2WD51B0KA		0.33	1	115				3500	2.94	K	12.4	46.0	M	54	7.5	1.0		90
2WD51B8KA	208			6.8	31.0	K	68				9.7	2.4						
2WD51B1KA	230			6.2	34.5	M	53				9.6	4.0						
2WD51C0JA	0.5	1	115	3500	3.19	J	14.5	46.0	M	54	7.5	1.0	94					
2WD51C8JA			208				8.4	31.0	K	68	9.7	2.4						
2WD51C1JA			230				7.6	34.5	M	53	9.6	4.0						
2WD51C2JA		3	200				4.9	22.6	R	68	NA	3.8						
2WD51C3JA			230				3.6	18.8	R	70	NA	5.8						
2WD51C4JA			460				1.8	9.4	R	70	NA	23.2						
2WD51C5JA		575	1.5				7.5	R	62	NA	35.3							
2WD51D8HA	0.75	1	208	3500	3.44	H	11.0	31.0	K	68	9.7	2.4	98					
2WD51D1HA			230				10.0	27.5	J	65	12.2	2.7						
2WD51D2HA		3	200				6.2	20.6	L	64	NA	5.7						
2WD51D3HA			230				5.4	15.7	K	68	NA	8.6						
2WD51D4HA			460				2.7	7.9	K	68	NA	34.2						
2WD51D5HA		575	2.2				9.9	L	78	NA	26.5							
2WD51E8AA	1	1	208	3500	3.75	A	14.5	59.0	K	68	9.3	1.1	104					
2WD51E1AA			230				13.0	36.2	J	69	10.3	2.1						
2WD51E2AA		3	200				8.6	37.6	M	77	NA	2.7						
2WD51E3AA			230				7.5	24.1	L	79	NA	4.1						
2WD51E4AA			460				3.8	12.1	L	79	NA	16.2						
2WD51E5AA		575	3.1				9.9	L	78	NA	26.5							

To order a pump with a 3" NPT discharge, change the 1st character to a 3, ex. 3WD51E5AA

APPLICATION DATA

Maximum Solid Size	2"
Minimum Casing Thickness	5/16"
Casing Corrosion Allowance	1/8"
Maximum Working Pressure	22 PSI
Maximum Submergence	50 feet
Minimum Submergence	Fully submerged for continuous operation 6" below top of motor for intermittent operation
Maximum Environmental Temperature	40°C (104°F) continuous operation 60°C (140°F) intermittent operation

CONSTRUCTION DETAILS

Power Cable - Type	16/3, type SJTOW: single phase, 1/2 HP 14/3, type STOW: single phase, 3/4 & 1 HP 14/4, type STOW: all three phase
Sensor Cable - Type	16/2, type SJTOW: seal sensor only 18/4, type SJTOW: optional seal/heat sensor
Motor Cover	Gray Cast Iron - ASTM A48 Class 30
Bearing Housing	Gray Cast Iron - ASTM A48 Class 30
Seal Housing	Gray Cast Iron - ASTM A48 Class 30
Casing	Gray Cast Iron - ASTM A48 Class 30
Impeller	Gray Cast Iron - ASTM A48 or Cast Bronze - ASTM B584 C87600
Motor Shaft	AISI 300 Series Stainless Steel
Motor Design	NEMA 48 Frame, oil filled with Class F Insulation
Motor Overload Protection	Single Phase: on winding thermal overload protection Three Phase: require ambient compensated Class 10, quick trip overloads in the control panel.
Motor Seal Fail (Moisture) Detection	Seal fail sensor in an oil-filled seal chamber. Connect to an optional relay in control panel.
Optional Motor Thermal Protection	Normally closed on-winding thermostats open at 275° F (135° C) and close at 112° F (78° C). Require terminal connection in the control panel.
External Hardware	300 Series Stainless Steel
Impeller Type	Semi-opened with pump out vanes on back shroud - 1750 RPM Enclosed with pump out vanes on back shroud - 3500 RPM
Oil Capacity - Seal Chamber	10 ounces
Oil Capacity - Motor Chamber	4.0 quarts

STANDARD PARTS

Ball Bearing	Upper	Single row ball - SKF™ 6203-2Z
	Lower	Single row ball - SKF™ 6203-2Z
Mechanical Seals - Standard	Upper	Carbon/Ceramic; John Crane Type 6
	Lower	Silicon Carbon/Silicon Carbon; Type 16
Mechanical Seals - Optional Lower		Silicon Carbide/Tungsten Carbide: Type 16
O-Ring - Stuffing Box		BUNA-N, AS 568A-163
O-Ring - Motor Cover		BUNA-N, AS 568A-166

DIMENSIONS

(All dimensions are in inches. Do not use for construction purposes.)

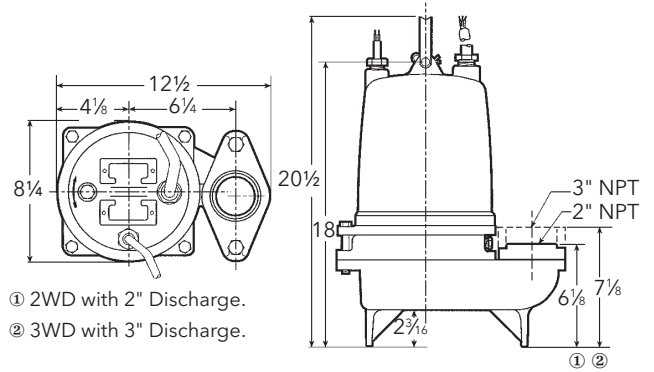

MATERIALS OF CONSTRUCTION

Item No.	Part Name	Material				
		Standard	Optional			
1	Impeller	1003	1179			
2	Motor cover	1003				
3	Shaft	300 Series SS				
4	Fasteners	300 Series SS				
5	Ball bearings	Steel				
6	Power cable	STOW, 20 feet			Additional lengths	
	Seal sensor cable					
7	O-ring	BUNA-N				
8	Outer Mech. Seal	Service	Rotary	Stationary	Elastomers	Metal Parts
	OPT	Heavy duty	Silicon Carbide	Tungsten Carbide	BUNA-N	300 Series SS
	STD	Mild abrasives	Silicon Carbide		BUNA-N	300 Series SS
Material Code		Engineering Standard				
1003		Cast iron – ASTM A48 Class 30				
1179		Silicon bronze – ASTM C87600				

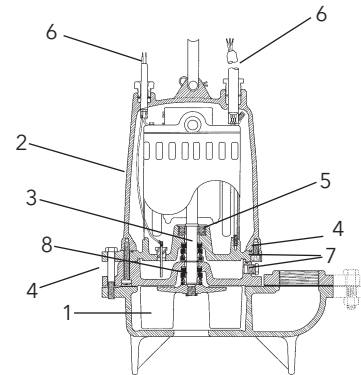

xylem
Let's Solve Water

Xylem Inc.
2881 East Bayard Street Ext., Suite A
Seneca Falls, NY 13148
Phone: (866) 325-4210
Fax: (888) 322-5877
www.gouldswatertechnology.com

Goulds is a registered trademark of Goulds Pumps, Inc. and is used under license.
© 2016 Xylem Inc. B2WD/3WD R2 March 2016