

xylem
Let's Solve Water

CURVE BOOK
CeSV5060 R4

e-SV Low NPSH Curves

E-SV SERIES VERTICAL MULTI-STAGE PUMPS

 **GOULDS**
WATER TECHNOLOGY
a xylem brand

Contents

Numbering System for 1-22SV Liquid End Only	2
Numbering System for 33-125SV Liquid End Only	3
Numbering System for 1-22SV Pump & Motor Combination	4
Numbering System for 33-125SV Pump & Motor Combination	5
3500 rpm Low NPSH Curves, Dimensions and Weights.	6-23
2900 rpm Low NPSH Curves, Dimensions and Weights.	24-41
Table of Hydraulic Performances at 3500 rpm	42
Table of Hydraulic Performances at 2900 rpm	48

e-SV Multistage Pumps

Product Code for 1 - 22SV Liquid End Only

Each e-SV pump is identified by a product code on the pump label. Each digit in the code is described below. The product code is also the catalog number for the pump.

Note: Not all combinations are possible.

Example Product Code

22 SV 0 2 F E 3 0

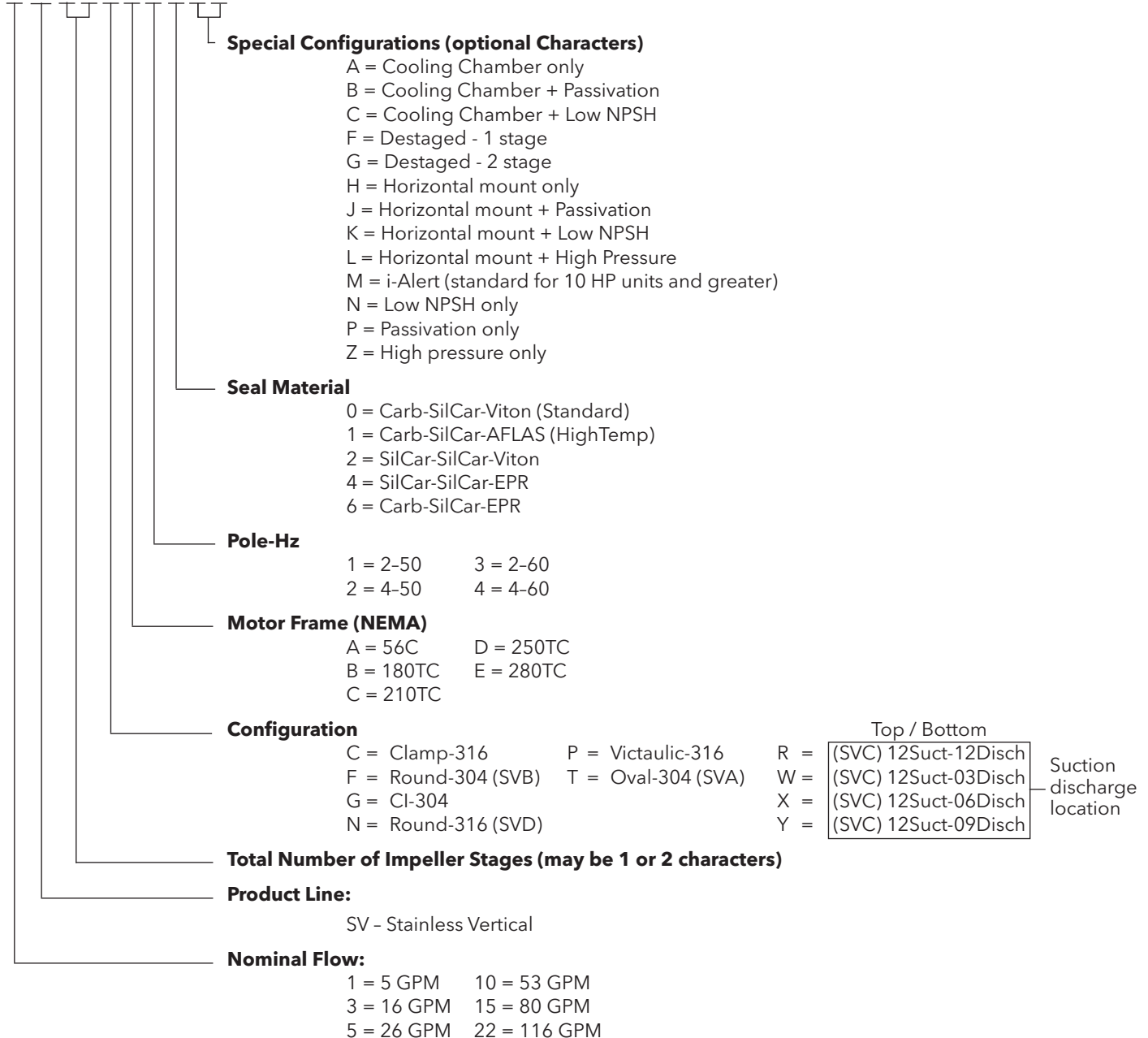

Commercial Water

e-SV Multistage Pumps

Product Code for 33 - 125SV Liquid End Only

Each e-SV pump is identified by a product code on the pump label. Each digit in the code is described below. The product code is also the catalog number for the pump.

Note: Not all combinations are possible.

Example Product Code

125 SV 8 1 2 B F E 2 0

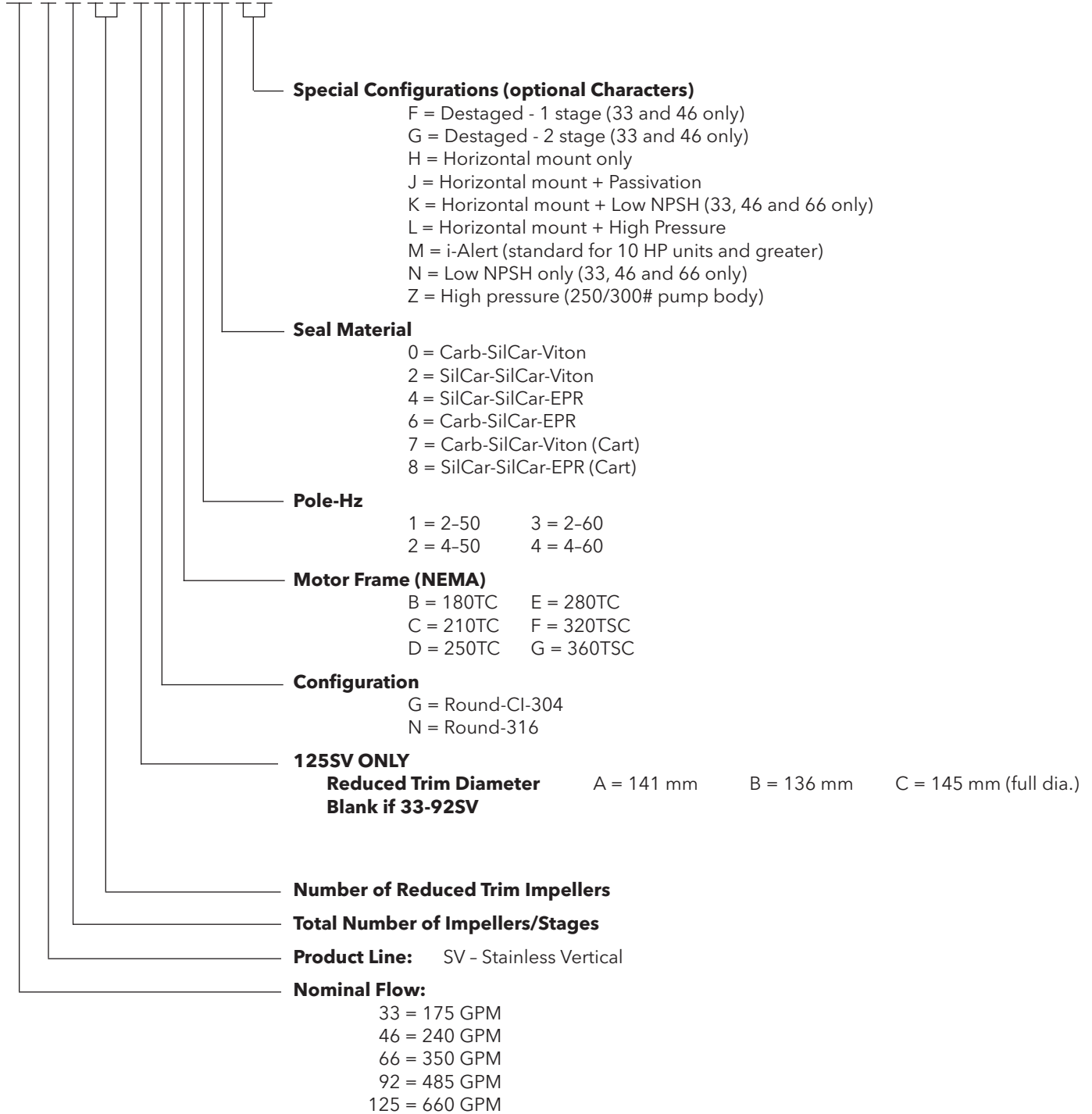

Commercial Water

e-SV Multistage Pumps

Product Code for 1 - 22SV Pump & Motor Combination

Each e-SV pump is identified by a product code on the pump label. Each digit in the code is described below. The product code is also the catalog number for the pump.

Note: Not all combinations are possible.

Example Product Code

2 SV 2 2 F A 2 F 5 1 A H

Special Configurations (1 or 2 Characters)

- | | |
|------------------------------------|--|
| A = Cooling Chamber only | K = Horizontal mount + Low NPSH |
| B = Cooling Chamber + Passivation | L = Horizontal mount + High Pressure |
| C = Cooling Chamber + Low NPSH | M = i-Alert (standard for 10 HP units and greater) |
| F = Destaged - 1 stage | N = Low NPSH only |
| G = Destaged - 2 stage | P = Passivation only |
| H = Horizontal mount only | Z = High Press (250/300# pump body) |
| J = Horizontal mount + Passivation | |

Seal Material

- | | |
|----------------------------------|-----------------------|
| 0 = Carb-SilCar-Viton | 4 = SilCar-SilCar-EPR |
| 1 = Carb-SilCar-AFLAS (HighTemp) | 6 = Carb-SilCar-EPR |
| 2 = SilCar-SilCar-Viton | |

Motor Enclosure

- | | |
|-------------------|---------------|
| 1 = ODP | 7 = Prem-XP |
| 2 = TEFC | 8 = Prem-WD |
| 3 = X-Proof | 9 = Marine |
| 4 = WD - Tropical | A = Chem |
| 5 = Prem-ODP | B = Prem-Chem |
| 6 = Prem-TEFC | |

Voltage

- | | | |
|-----------------|-----------------|---------------------|
| A = 115-230 | H = 190/380 | R = 220 |
| B = 230 | J = 115/208-230 | S = 415 |
| C = 230-460 | K = 208 | T = 220/380 WYE |
| D = 460 | L = 208-230 | U = 380-660 WYE |
| E = 575 | M = 190/380/415 | V = 208-230/460 WYE |
| F = 208-230/460 | N = 380 | |
| G = 200 | P = 110/220 | |

Pole-Hz-Phase

- | | |
|------------|------------|
| 1 = 2-50-1 | 5 = 4-50-1 |
| 2 = 2-50-3 | 6 = 4-50-3 |
| 3 = 2-60-1 | 7 = 4-60-1 |
| 4 = 2-60-3 | 8 = 4-60-3 |

HP Rating

- | | |
|----------|---------|
| A = 0.50 | H = 7.5 |
| B = 0.75 | J = 10 |
| C = 1.00 | K = 15 |
| D = 1.50 | L = 20 |
| E = 2 | M = 25 |
| F = 3 | N = 30 |
| G = 5 | P = 40 |

Configuration OPTION

- | |
|---------------------|
| C = Clamp-316 |
| F = Round-304 (SVB) |
| G = Cl-304 |
| N = Round-316 (SVD) |
| P = Victaulic-316 |
| T = Oval-304 (SVA) |

Top / Bottom

- | | | |
|-----|----------------------|----------------------------------|
| R = | (SVC) 12Suct-12Disch | Suction
discharge
location |
| W = | (SVC) 12Suct-03Disch | |
| X = | (SVC) 12Suct-06Disch | |
| Y = | (SVC) 12Suct-09Disch | |

Total Number of Impeller Stages (may be 1 or 2 characters)

Product Line:

SV - Stainless Vertical

Nominal Flow:

- | | |
|------------|--------------|
| 1 = 5 GPM | 10 = 53 GPM |
| 3 = 16 GPM | 15 = 80 GPM |
| 5 = 26 GPM | 22 = 116 GPM |

Commercial Water

e-SV Multistage Pumps

Product Code for 33 - 125SV Pump & Motor Combination

Each e-SV pump is identified by a product code on the pump label. Each digit in the code is described below. The product code is also the catalog number for the pump.

Note: Not all combinations are possible.

Example Product Code

125 SV 8 2 A G K 3 F 2 0

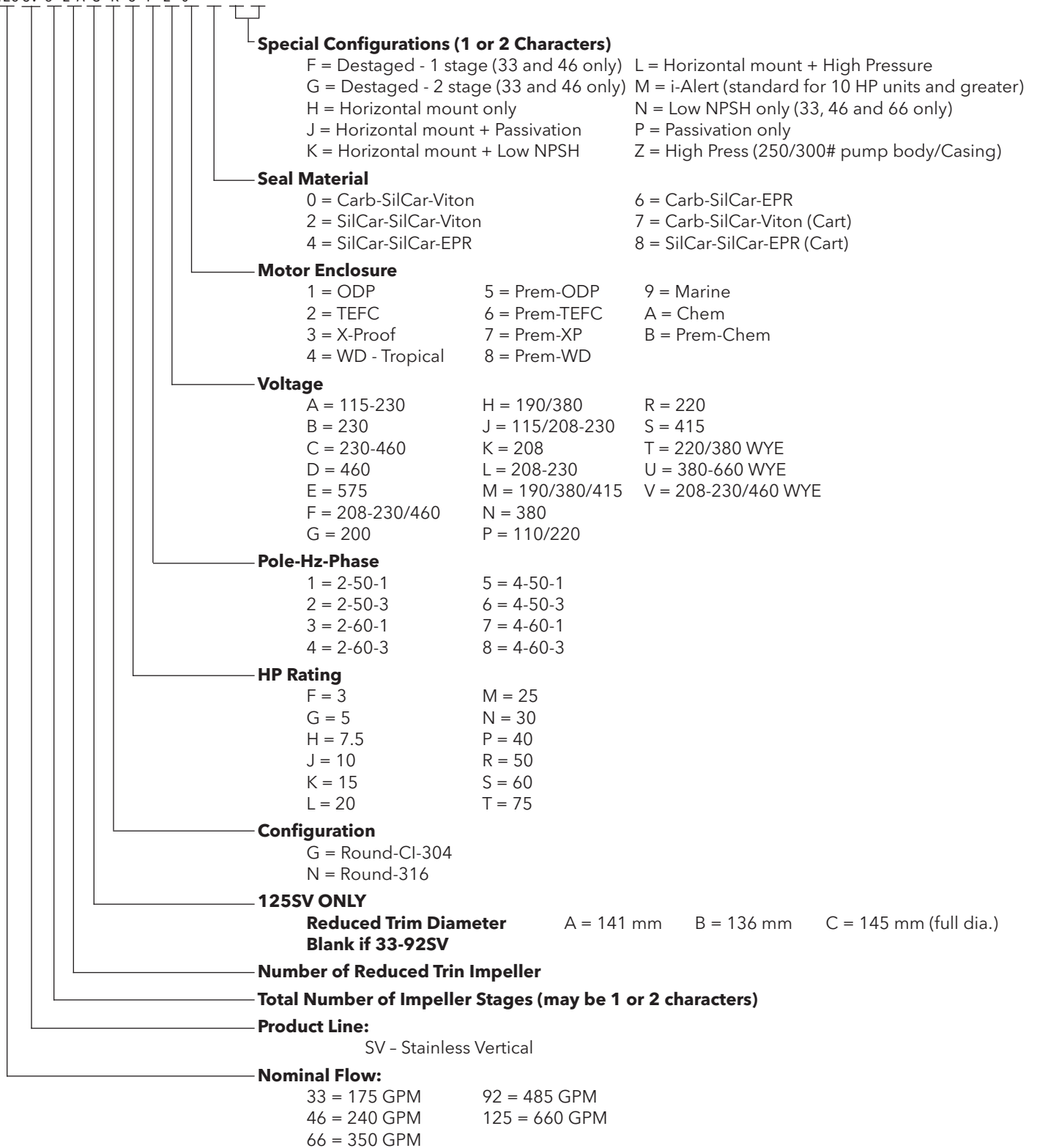

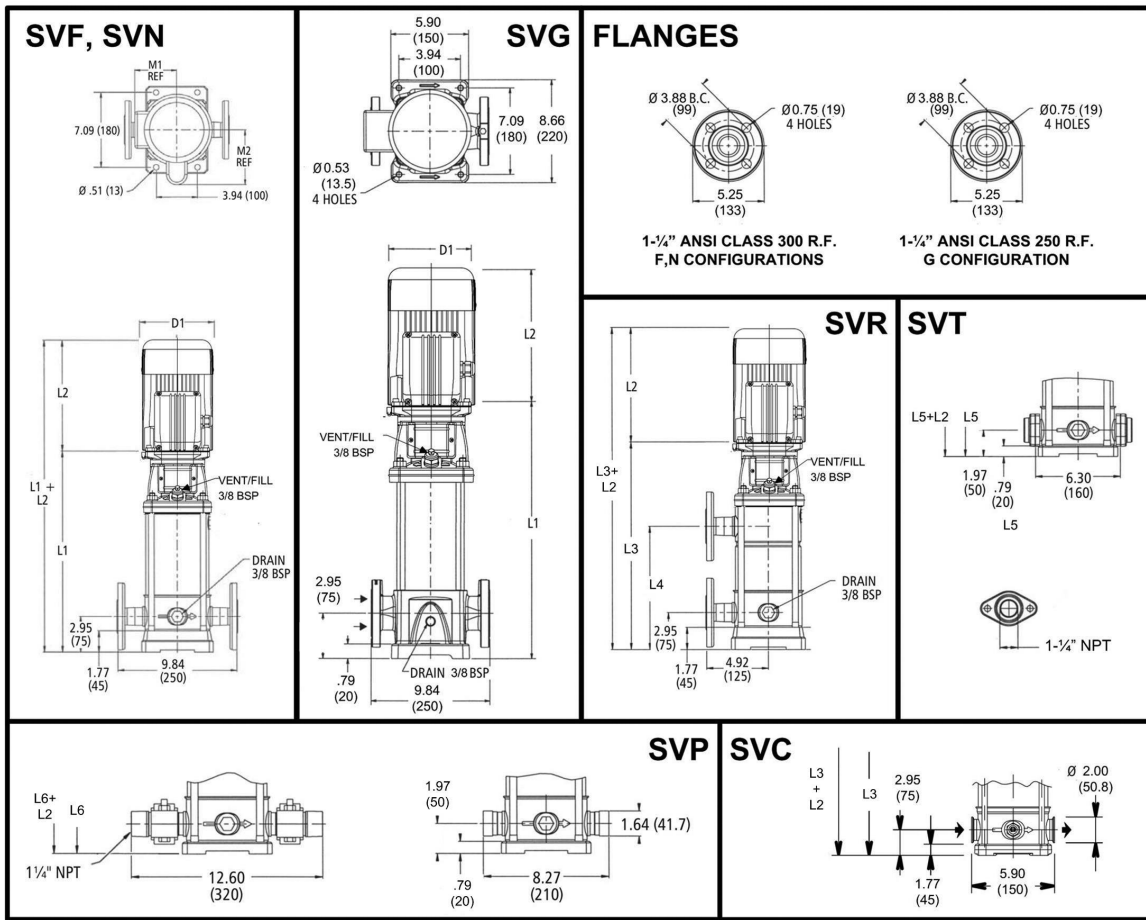

All dimensions are in inches (mm).

PUMP DIMENSIONS AND WEIGHTS - 1SV SERIES – 60Hz, 3500 RPM ODP/TEFC Enclosures

Pump Type Stages	Motor				Dimensions (in)											Weight (lbs.)												
	HP	NEMA Frame			L2				L3	L4	L5	L6	M (Ref.)	D1 (max.)				D2	Pump Only	Motor				Pump/Motor				
		ODP 1Ø	TEFC 1Ø	ODP 3Ø	TEFC 3Ø	L1	ODP 1Ø	TEFC 1Ø						ODP 3Ø	TEFC 3Ø	ODP 1Ø	TEFC 1Ø			ODP 3Ø	TEFC 3Ø	ODP 1Ø	TEFC 1Ø	ODP 3Ø	TEFC 3Ø	ODP 1Ø	TEFC 1Ø	ODP 3Ø
1SV-02	0.5	56C			13.27	9.16	9.29	9.16	9.29	-	-	12.29	12.29	5.19	6.19	6.19	6.19	6.19	4.13	25	21	21	19	19	46	46	44	44
1SV-03					13.27	9.16	9.29	9.16	9.29	-	-	12.29	12.29	5.19	6.19	6.19	6.19	6.19	4.13	26	21	21	19	19	47	47	45	45
1SV-04					14.06	9.16	9.29	9.16	9.29	-	-	13.07	13.07	5.19	6.19	6.19	6.19	6.19	4.13	27	21	21	19	19	48	48	46	46
1SV-05	0.75			14.85	10.79	9.91	9.16	9.29	-	-	13.86	13.86	5.19	6.19	6.19	6.19	6.19	4.13	28	27	29	21	21	55	57	49	49	
1SV-06				15.63	10.79	9.91	9.16	9.29	-	-	14.65	14.65	5.19	6.19	6.19	6.19	6.19	4.13	28	27	29	21	21	55	57	49	49	
1SV-07				16.42	10.66	11.19	9.16	9.29	-	-	15.44	15.44	5.74	6.19	7.19	6.19	6.19	4.13	29	32	40	23	23	61	69	52	52	
1SV-08	1			17.21	10.66	11.19	9.16	9.29	17.21	8.94	16.22	16.22	5.74	6.19	7.19	6.19	6.19	4.13	30	32	40	23	23	62	70	53	53	
1SV-09				18.00	10.66	11.19	9.16	9.29	18.00	9.72	17.01	17.01	5.74	6.19	7.19	6.19	6.19	4.13	31	32	40	23	23	63	71	54	54	
1SV-10				18.78	10.67	11.19	10.66	9.91	18.78	10.51	17.80	17.80	5.74	6.19	7.19	6.19	6.19	4.72	32	32	40	30	28	64	72	62	60	
1SV-11	1.5			19.57	10.67	11.19	10.66	9.91	19.57	11.30	18.59	18.59	5.74	6.19	7.19	6.19	6.19	4.72	33	32	40	30	28	65	73	63	61	
1SV-12				20.36	10.67	11.19	10.66	9.91	20.36	12.09	19.37	19.37	5.74	6.19	7.19	6.19	6.19	4.72	34	32	40	30	28	66	74	64	62	
1SV-13				21.14	10.67	11.19	10.66	9.91	21.14	12.87	20.16	20.16	5.74	6.19	7.19	6.19	6.19	4.72	35	32	40	30	28	67	75	65	63	
1SV-14	2			21.93	10.67	11.19	10.66	9.91	21.93	13.66	20.95	20.95	5.74	6.19	7.19	6.19	6.19	4.72	36	32	40	30	28	68	76	66	64	
1SV-15				22.72	11.18	12.06	11.16	10.79	22.72	14.45	21.74	21.74	5.74	7.19	7.19	6.19	6.19	4.72	37	43	51	32	33	80	88	69	70	
1SV-16				23.51	11.18	12.06	11.16	10.79	23.51	15.24	22.52	22.52	5.74	7.19	7.19	6.19	6.19	4.72	38	43	51	32	33	81	89	70	71	
1SV-17	3			24.29	11.18	12.06	11.16	10.79	24.29	16.02	23.31	23.31	5.74	7.19	7.19	6.19	6.19	4.72	38	43	51	32	33	81	89	70	71	
1SV-18				25.08	11.18	12.06	11.16	10.79	25.08	16.81	24.10	24.10	5.74	7.19	7.19	6.19	6.19	4.72	39	43	51	32	33	82	90	71	72	
1SV-19				25.87	11.18	12.06	11.16	10.79	25.87	17.60	-	24.89	5.74	7.19	7.19	6.19	6.19	4.72	40	43	51	32	33	83	91	72	73	
1SV-20	5			26.66	11.57	13.44	11.18	11.16	26.66	18.39	-	25.67	5.75	6.50	7.19	7.16	7.19	5.51	41	49	64	41	44	90	105	82	85	
1SV-21				27.44	11.57	13.44	11.18	11.16	27.44	19.17	-	26.46	5.75	6.50	7.19	7.16	7.19	5.51	42	49	64	41	44	91	106	83	86	
1SV-22				28.23	11.57	13.44	11.18	11.16	28.23	19.96	-	27.25	5.75	6.50	7.19	7.16	7.19	5.51	43	49	64	41	44	92	107	84	87	
1SV-23	5			29.02	11.57	13.44	11.18	11.16	29.02	20.75	-	28.03	5.75	6.50	7.19	7.16	7.19	5.51	45	49	64	41	44	94	109	86	89	
1SV-24				29.81	11.57	13.44	11.18	11.16	29.81	21.54	-	28.82	5.75	6.50	7.19	7.16	7.19	5.51	46	49	64	41	44	95	110	87	90	
1SV-25				30.59	11.57	13.44	11.18	11.16	30.59	22.32	-	29.61	5.75	6.50	7.19	7.16	7.19	5.51	47	49	64	41	44	96	111	88	91	
1SV-26	5			31.38	11.57	13.44	11.18	11.16	31.38	23.11	-	30.40	5.75	6.50	7.19	7.16	7.19	5.51	47	49	64	41	44	96	111	88	91	
1SV-27				32.17	11.57	13.44	11.18	11.16	32.17	23.90	-	31.18	5.75	6.50	7.19	7.16	7.19	5.51	48	49	64	41	44	97	112	89	92	
1SV-28				32.96	11.57	13.44	11.18	11.16	32.96	24.68	-	31.97	5.75	6.50	7.19	7.16	7.19	5.51	49	49	64	41	44	98	113	90	93	
1SV-29	5			34.14	11.57	13.44	11.18	11.16	34.14	25.47	-	33.15	5.75	6.50	7.19	7.16	7.19	5.51	50	49	64	41	44	99	114	91	94	
1SV-30			184TC	182TC	184TC	35.23	13.93	15.43	12.55	13.93	-	-	-	34.25	6.87	8.88	8.86	9.02	8.86	5.51	53	81	92	62	69	134	145	115

Performance Curve

1SV 60 Hz 3500 RPM

LOW NPSH CURVE

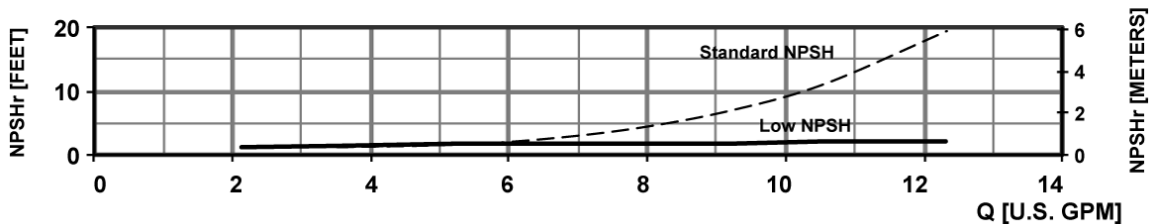
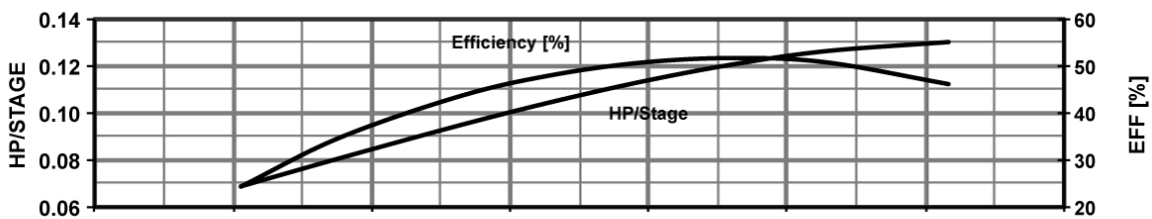
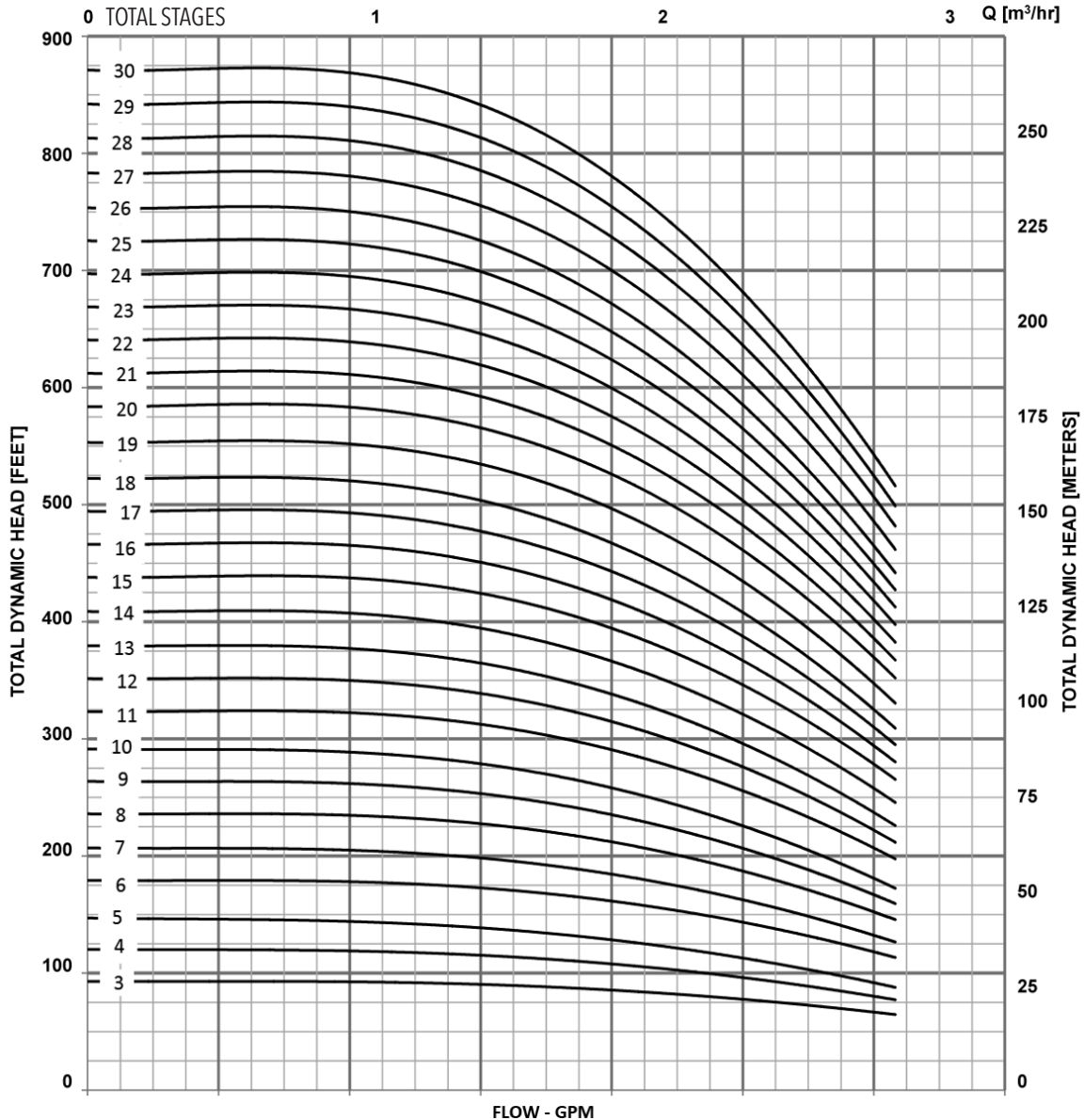

MINIMUM FLOW RATE: 2 GPM [$\frac{1}{2}$ m³/hr]

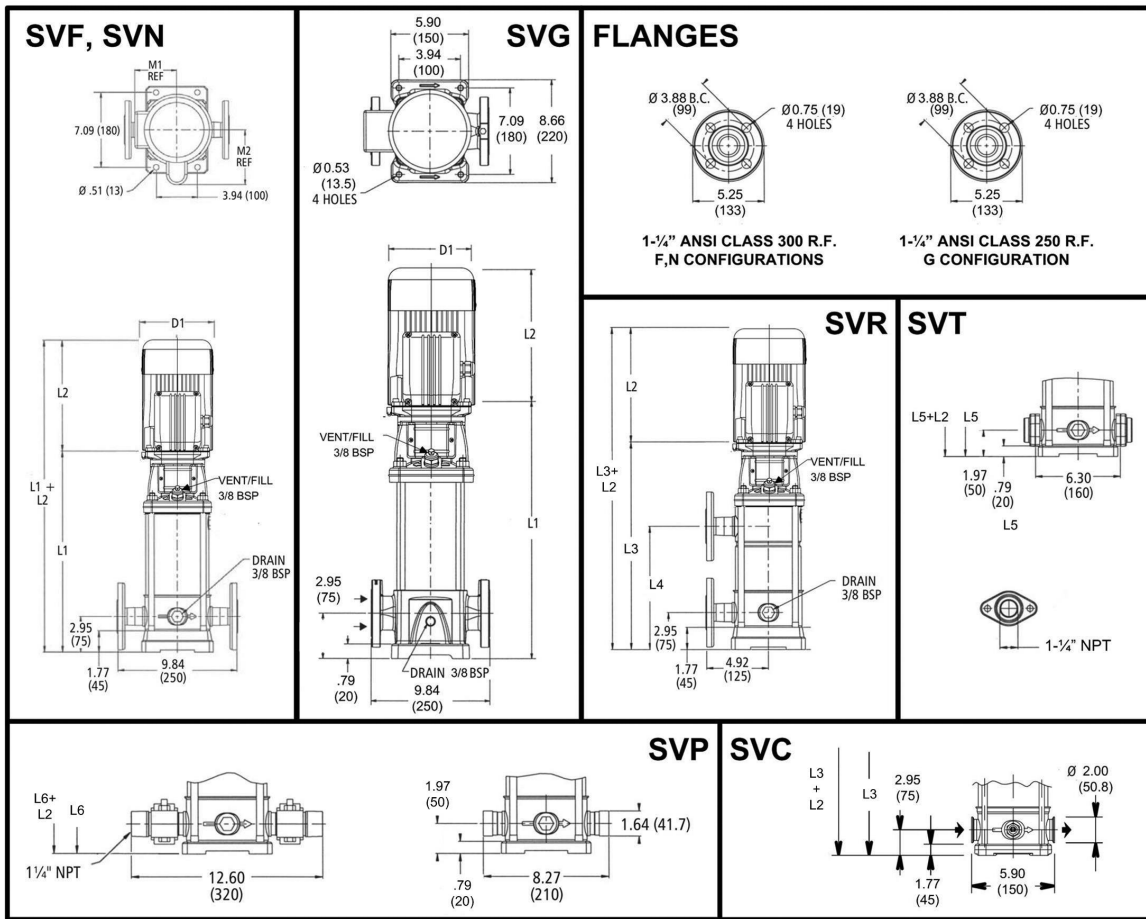

All dimensions are in inches (mm).

PUMP DIMENSIONS AND WEIGHTS - 3SV SERIES – 60Hz, 3500 RPM ODP/TEFC Enclosures

Pump Type Stages	HP	Motor				Dimensions (in)													Weight (lbs.)										
		NEMA Frame				L2				D1 (max.)					Pump	Motor				Pump/Motor									
		ODP 1Ø	TEFC 1Ø	ODP 3Ø	TEFC 3Ø	L1	ODP 1Ø	TEFC 1Ø	ODP 3Ø	TEFC 3Ø	L3	L4	L5	L6		M (Ref.)	ODP 1Ø	TEFC 1Ø	ODP 3Ø	TEFC 3Ø	D2	ODP 1Ø	TEFC 1Ø	ODP 3Ø	TEFC 3Ø	ODP 1Ø	TEFC 1Ø	ODP 3Ø	TEFC 3Ø
3SV-03	0.75					13.27	10.79	9.91	9.16	9.29	-	-	12.29	12.29	5.19	6.19	6.19	6.19	6.19	4.13	25	27	29	21	21	52	54	46	46
3SV-04						14.06	10.66	11.19	9.16	9.29	-	-	13.07	13.07	5.74	6.19	7.19	6.19	6.19	4.13	26	32	40	23	23	58	66	49	49
3SV-05						14.85	10.66	11.19	9.16	9.29	-	-	13.86	13.86	5.74	6.19	7.19	6.19	6.19	4.13	27	32	40	23	23	59	67	50	50
3SV-06						15.63	10.67	11.19	10.66	9.91	-	-	14.65	14.65	5.74	6.19	7.19	6.19	6.19	4.72	28	32	40	30	28	60	68	58	56
3SV-07						16.42	10.67	11.19	10.66	9.91	-	-	15.44	15.44	5.74	6.19	7.19	6.19	6.19	4.72	30	32	40	30	28	62	70	60	58
3SV-08						17.21	11.18	12.06	11.16	10.79	17.21	8.94	16.22	16.22	5.74	7.19	7.19	6.19	6.19	4.72	31	43	51	32	33	74	82	63	64
3SV-09						18.00	11.18	12.06	11.16	10.79	18.00	9.72	17.01	17.01	5.74	7.19	7.19	6.19	6.19	4.72	32	43	51	32	33	75	83	64	65
3SV-10						18.78	11.18	12.06	11.16	10.79	18.78	10.51	17.80	17.80	5.74	7.19	7.19	6.19	6.19	4.72	33	43	51	32	33	76	84	65	66
3SV-11						19.57	11.57	13.44	11.18	11.16	19.57	11.30	18.59	18.59	5.75	6.50	7.19	7.16	7.19	5.51	34	49	64	41	44	83	98	75	78
3SV-12						20.36	11.57	13.44	11.18	11.16	20.36	12.09	19.37	19.37	5.75	6.50	7.19	7.16	7.19	5.51	35	49	64	41	44	84	99	76	79
3SV-13						21.14	11.57	13.44	11.18	11.16	21.14	12.87	20.16	20.16	5.75	6.50	7.19	7.16	7.19	5.51	36	49	64	41	44	85	100	77	80
3SV-14						21.93	11.57	13.44	11.18	11.16	21.93	13.66	20.95	20.95	5.75	6.50	7.19	7.16	7.19	5.51	37	49	64	41	44	86	101	78	81
3SV-15						22.72	11.57	13.44	11.18	11.16	22.72	14.45	-	21.74	5.75	6.50	7.19	7.16	7.19	5.51	38	49	64	41	44	87	102	79	82
3SV-16						23.51	11.57	13.44	11.18	11.16	23.51	15.24	-	22.52	5.75	6.50	7.19	7.16	7.19	5.51	39	49	64	41	44	88	103	80	83
3SV-17						24.99	13.93	15.43	12.55	13.93	24.99	16.02	-	24.01	6.87	8.88	8.86	9.02	8.86	5.51	42	81	92	62	69	123	134	104	111
3SV-18						25.78	13.93	15.43	12.55	13.93	25.78	16.81	-	24.80	6.87	8.88	8.86	9.02	8.86	5.51	43	81	92	62	69	124	135	105	112
3SV-19						26.57	13.93	15.43	12.55	13.93	26.57	17.60	-	25.59	6.87	8.88	8.86	9.02	8.86	5.51	43	81	92	62	69	124	135	105	112
3SV-20						27.36	13.93	15.43	12.55	13.93	27.36	18.39	-	26.37	6.87	8.88	8.86	9.02	8.86	5.51	44	81	92	62	69	125	136	106	113
3SV-21						28.14	13.93	15.43	12.55	13.93	28.14	19.17	-	27.16	6.87	8.88	8.86	9.02	8.86	5.51	45	81	92	62	69	126	137	107	114
3SV-22						28.93	13.93	15.43	12.55	13.93	28.93	19.96	-	27.95	6.87	8.88	8.86	9.02	8.86	5.51	46	81	92	62	69	127	138	108	115
3SV-23						29.72	13.93	15.43	12.55	13.93	29.72	20.75	-	28.73	6.87	8.88	8.86	9.02	8.86	5.51	47	81	92	62	69	128	139	109	116
3SV-24						30.51	13.93	15.43	12.55	13.93	-	-	-	29.52	6.87	8.88	8.86	9.02	8.86	5.51	48	81	92	62	69	129	140	110	117
3SV-25						31.29	13.93	15.43	12.55	13.93	-	-	-	30.31	6.87	8.88	8.86	9.02	8.86	5.51	49	81	92	62	69	130	141	111	118
3SV-26						32.08	13.93	15.43	12.55	13.93	-	-	-	31.10	6.87	8.88	8.86	9.02	8.86	5.51	50	81	92	62	69	131	142	112	119
3SV-27						32.47	13.93	15.43	12.55	13.93	-	-	-	31.49	6.87	8.88	8.86	9.02	8.86	5.51	52	81	92	62	69	133	144	114	121
3SV-28						33.26	13.88	15.53	13.93	15.43	-	-	-	32.28	8.05	8.89	10.62	8.88	8.86	5.51	53	100	120	75	85	153	173	128	138
3SV-29						34.44	13.88	15.53	13.93	15.43	-	-	-	33.46	8.05	8.89	10.62	8.88	8.86	5.51	54	100	120	75	85	154	174	129	139
3SV-30						35.23	13.88	15.53	13.93	15.43	-	-	-	34.25	8.05	8.89	10.62	8.88	8.86	5.51	55	100	120	75	85	155	175	130	140

Performance Curve

3SV 60 Hz 3500 RPM

LOW NPSH CURVE

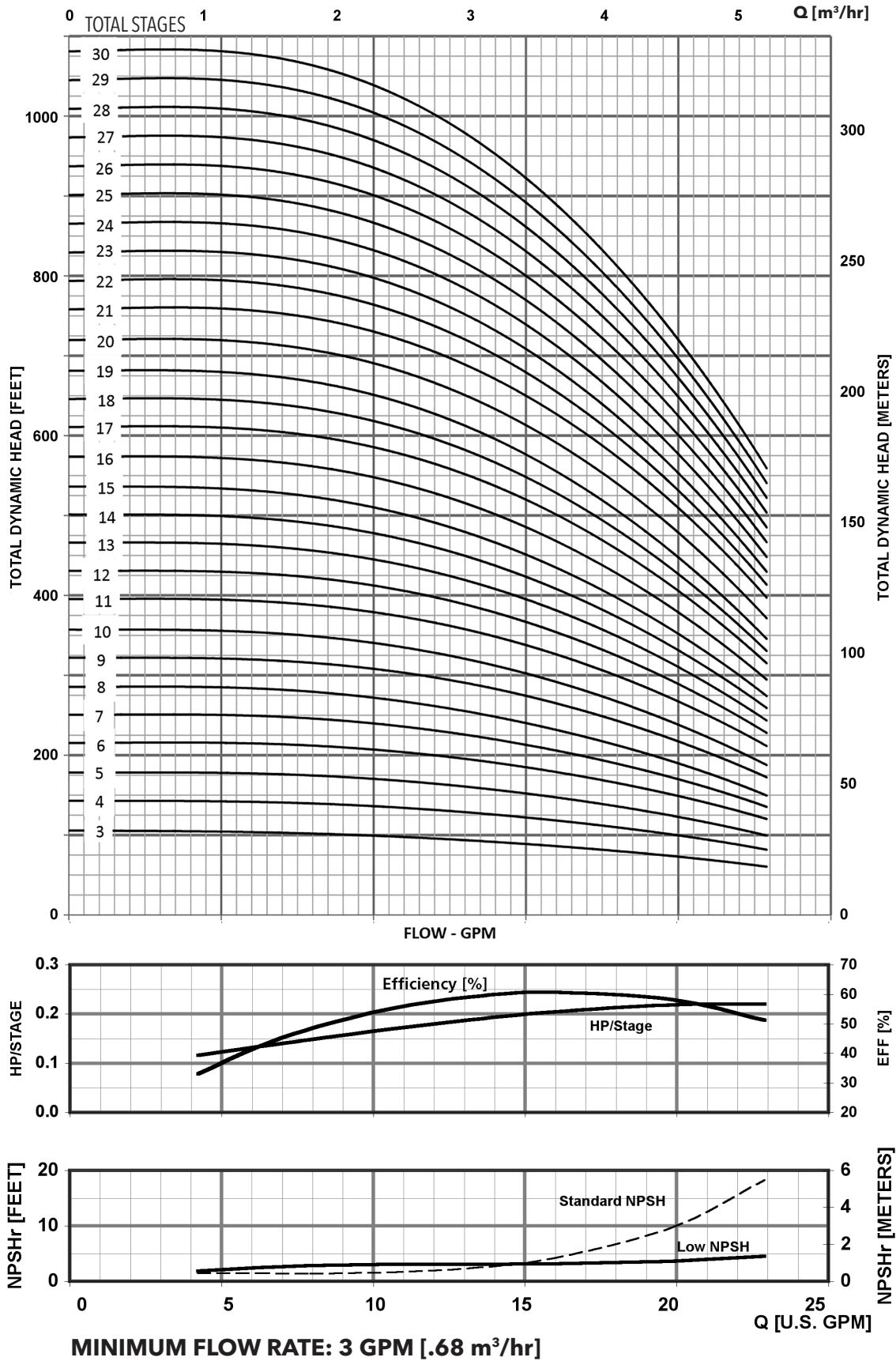

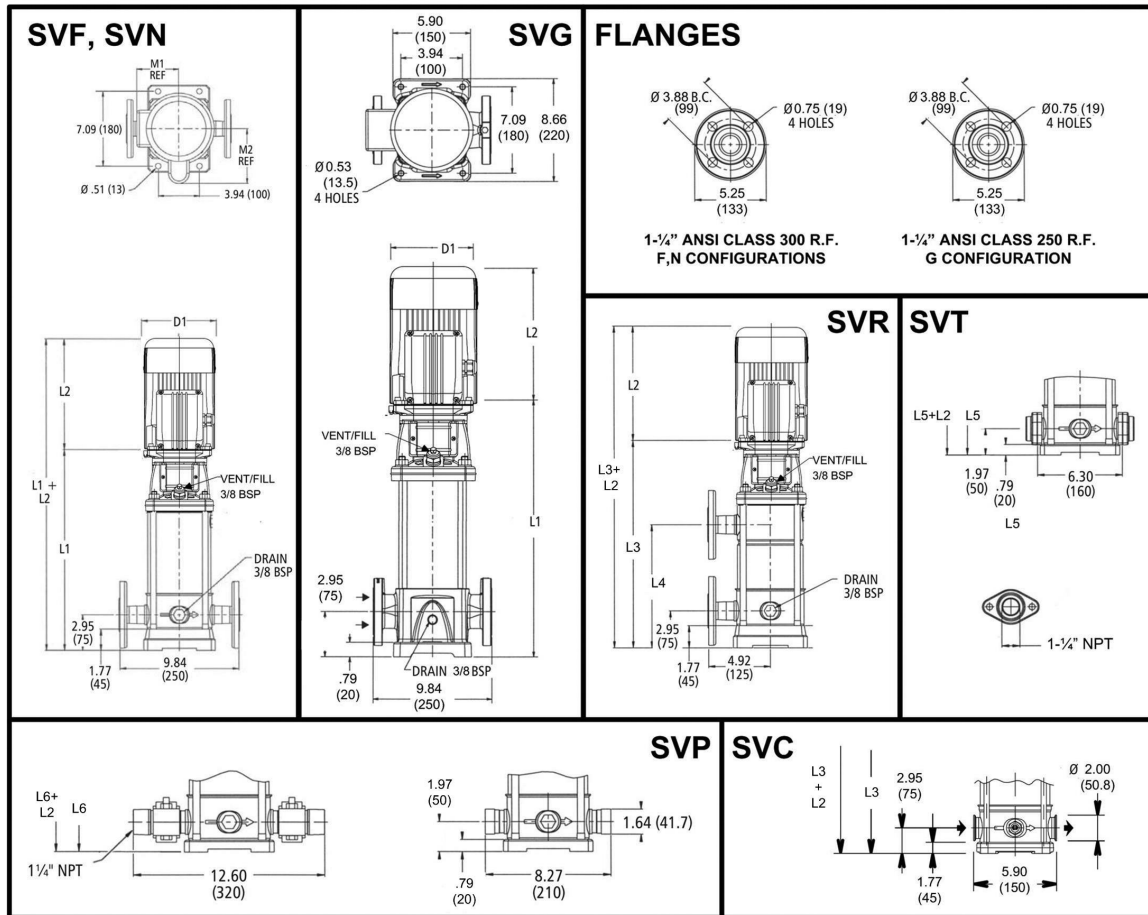

All dimensions are in inches (mm).

PUMP DIMENSIONS AND WEIGHTS - 5SV SERIES – 60Hz, 3500 RPM ODP/TEFC Enclosures

Pump Type Stages	Motor				Dimensions (in)											Weight (lbs.)												
	HP	NEMA Frame			L2				L3	L4	L5	L6	M (Ref.)	D1 (max.)				D2	Pump	Motor				Pump/Motor				
		ODP 1Ø	TEFC 1Ø	ODP 3Ø	TEFC 3Ø	L1	ODP 1Ø	TEFC 1Ø						ODP 3Ø	TEFC 3Ø	ODP 1Ø	TEFC 1Ø			ODP 3Ø	TEFC 3Ø	ODP 1Ø	TEFC 1Ø	ODP 3Ø	TEFC 3Ø	ODP 1Ø	TEFC 1Ø	ODP 3Ø
5SV-02	1	56C			13.86	10.66	11.19	9.16	9.29	-	-	12.88	12.88	5.74	6.19	7.19	6.19	6.19	4.13	25	32	40	23	23	57	65	48	48
5SV-03	1.5	56C			13.86	10.67	11.19	10.66	9.91	-	-	12.88	12.88	5.74	6.19	7.19	6.19	6.19	4.72	26	32	40	30	28	58	66	56	54
5SV-04		14.85	10.67	11.19	10.66	9.91	-	-	13.86	13.86	5.74	6.19	7.19	6.19	6.19	4.72	28	32	40	30	28	60	68	58	56	56		
5SV-05	2	56C			15.83	11.18	12.06	11.16	10.79	-	-	14.85	14.85	5.74	7.19	7.19	6.19	6.19	4.72	29	43	51	32	33	72	80	61	62
5SV-06	3	56C			16.81	11.57	13.44	11.18	11.16	-	-	15.83	15.83	5.75	6.50	7.19	7.16	7.19	5.51	30	49	64	41	44	79	94	71	74
5SV-07		17.80	11.57	13.44	11.18	11.16	17.80	9.53	16.81	16.81	5.75	6.50	7.19	7.16	7.19	5.51	31	49	64	41	44	80	95	72	75			
5SV-08		18.78	11.57	13.44	11.18	11.16	18.78	10.51	17.80	17.80	5.75	6.50	7.19	7.16	7.19	5.51	33	49	64	41	44	82	97	74	77			
5SV-09		19.77	11.57	13.44	11.18	11.16	19.77	11.50	18.78	18.78	5.75	6.50	7.19	7.16	7.19	5.51	33	49	64	41	44	82	97	74	77			
5SV-10	5	184TC	182TC	184TC	21.45	13.93	15.43	12.55	13.93	21.45	12.48	20.47	20.47	6.87	8.88	8.86	9.02	8.86	5.51	36	81	92	62	69	117	128	98	105
5SV-11					22.44	13.93	15.43	12.55	13.93	22.44	13.46	21.45	21.45	6.87	8.88	8.86	9.02	8.86	5.51	37	81	92	62	69	118	129	99	106
5SV-12					23.42	13.93	15.43	12.55	13.93	23.42	14.45	22.44	22.44	6.87	8.88	8.86	9.02	8.86	5.51	38	81	92	62	69	119	130	100	107
5SV-13					24.40	13.93	15.43	12.55	13.93	24.40	15.43	23.42	23.42	6.87	8.88	8.86	9.02	8.86	5.51	40	81	92	62	69	121	132	102	109
5SV-14		25.39	13.93	15.43	12.55	13.93	25.39	16.42	24.40	24.40	6.87	8.88	8.86	9.02	8.86	5.51	40	81	92	62	69	121	132	102	109			
5SV-15		26.37	13.93	15.43	12.55	13.93	26.37	17.40	-	25.39	6.87	8.88	8.86	9.02	8.86	5.51	41	81	92	62	69	122	133	103	110			
5SV-16		27.36	13.93	15.43	12.55	13.93	27.36	18.39	-	26.37	6.87	8.88	8.86	9.02	8.86	5.51	43	81	92	62	69	124	135	105	112			
5SV-17		7.5	213TC	184TC	28.54	13.88	15.53	13.93	15.43	28.54	19.37	-	27.55	8.05	8.89	10.62	8.88	8.86	5.51	45	100	120	75	85	145	165	120	130
5SV-18	29.33				13.88	15.53	13.93	15.43	29.33	20.35	-	28.34	8.05	8.89	10.62	8.88	8.86	5.51	46	100	120	75	85	146	166	121	131	
5SV-19	30.51				13.88	15.53	13.93	15.43	30.51	21.34	-	29.52	8.05	8.89	10.62	8.88	8.86	5.51	47	100	120	75	85	147	167	122	132	
5SV-20	31.69				13.88	15.53	13.93	15.43	31.69	22.32	-	30.70	8.05	8.89	10.62	8.88	8.86	5.51	48	100	120	75	85	148	168	123	133	
5SV-21	32.28				13.88	15.53	13.93	15.43	32.28	23.31	-	31.29	8.05	8.89	10.62	8.88	8.86	5.51	49	100	120	75	85	149	169	124	134	
5SV-22	33.34				13.88	15.53	13.93	15.43	33.34	24.29	-	32.36	8.05	8.89	10.62	8.88	8.86	5.51	50	100	120	75	85	150	170	125	135	
5SV-23	34.25				13.88	15.53	13.93	15.43	34.25	25.28	-	33.26	8.05	8.89	10.62	8.88	8.86	5.51	51	100	120	75	85	151	171	126	136	
5SV-24	35.31				13.88	15.53	13.93	15.43	-	-	-	34.33	8.05	8.89	10.62	8.88	8.86	5.51	53	100	120	75	85	153	173	128	138	
5SV-25	10	215TC	213TC	215TC	36.79	16.63	16.68	15.55	15.51	-	-	35.81	8.77	10.62	10.18	10.18	10.28	5.51	60	132	145	107	122	192	205	167	182	
5SV-26					37.86	16.63	16.68	15.55	15.51	-	-	36.87	8.77	10.62	10.18	10.18	10.28	5.51	61	132	145	107	122	193	206	168	183	
5SV-27					38.84	16.63	16.68	15.55	15.51	-	-	37.86	8.77	10.62	10.18	10.18	10.28	5.51	62	132	145	107	122	194	207	169	184	

Performance Curve

5SV 60 Hz 3500 RPM

LOW NPSH CURVE

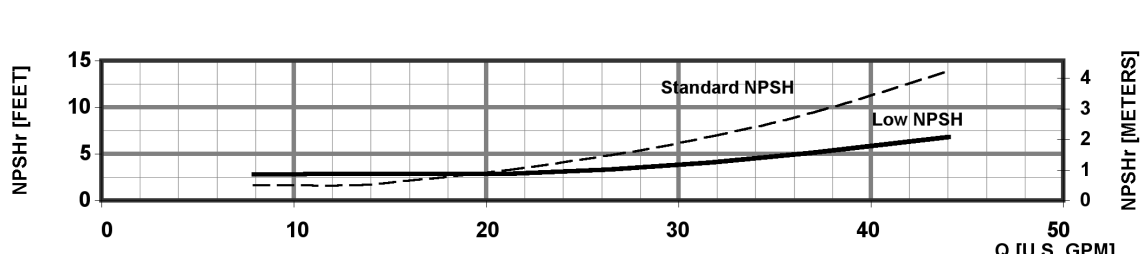
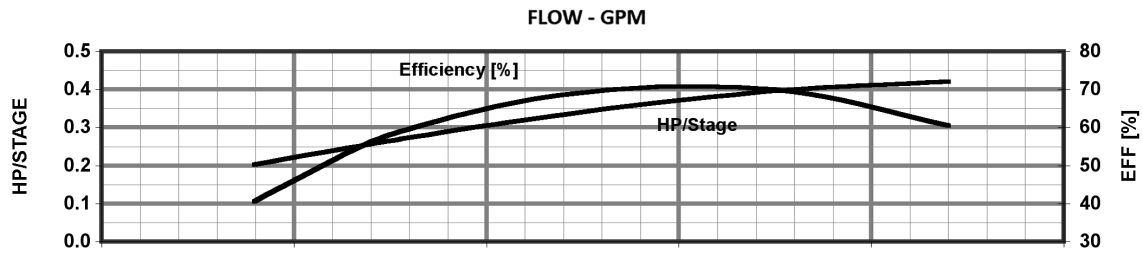
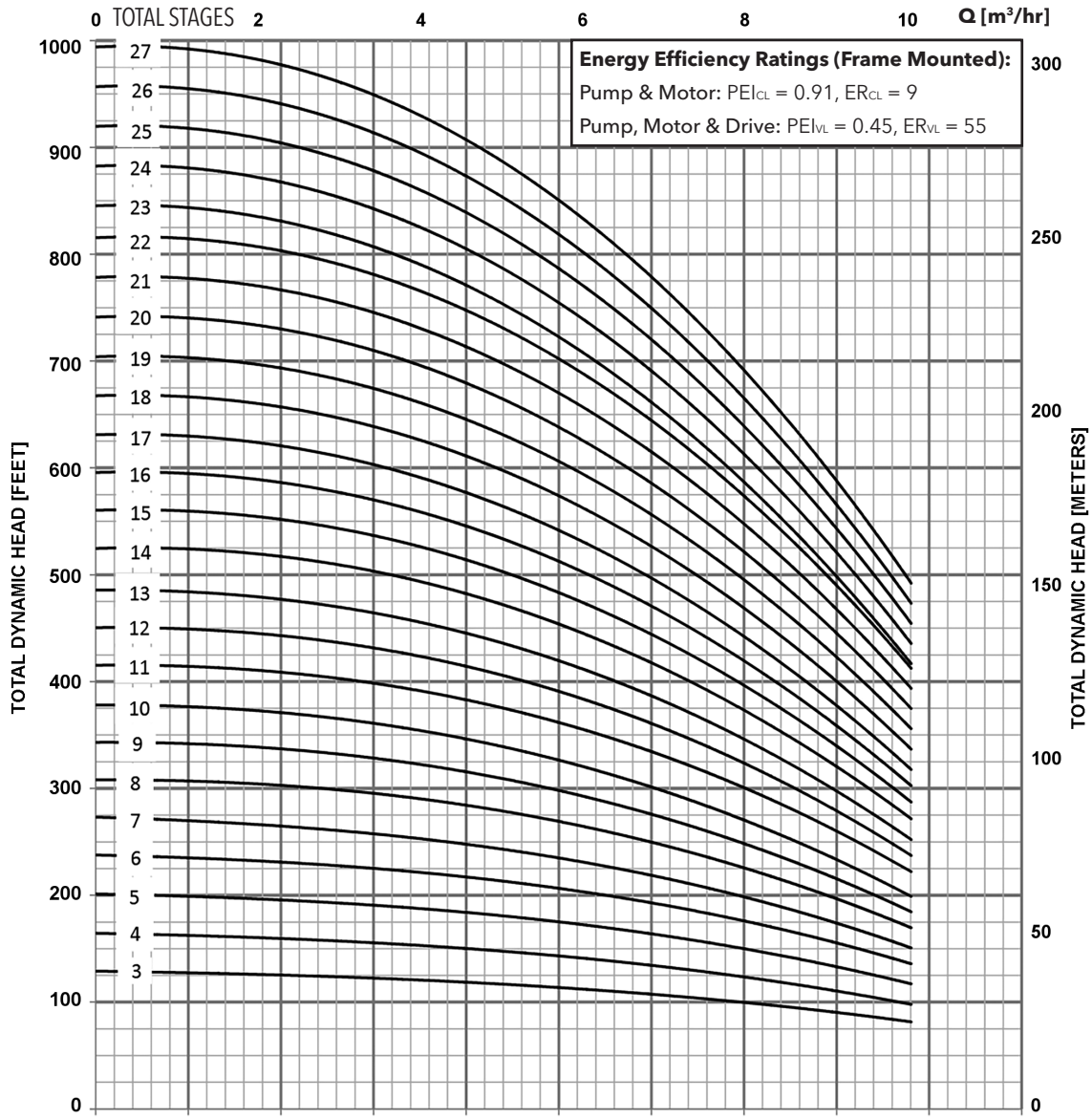

MINIMUM FLOW RATE: 7 GPM [1.6 m^3/hr]

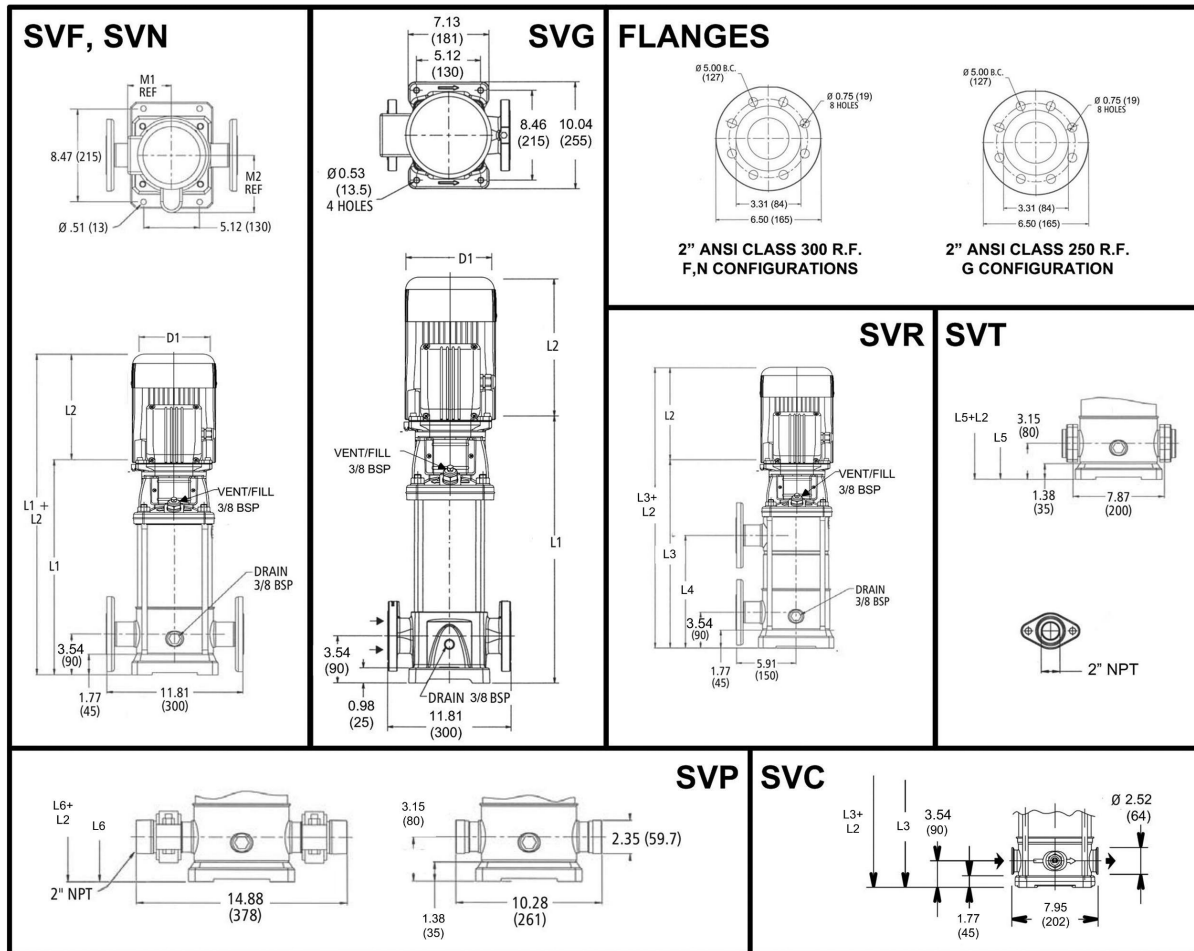

All dimensions are in inches (mm).

PUMP DIMENSIONS AND WEIGHTS - 10SV SERIES – 60Hz, 3500 RPM ODP/TEFC Enclosures

Pump Type Stages	Motor				Dimensions (in)												Weight (lbs.)											
	HP	NEMA Frame			L1	L2				L3	L4	L5	L6	M (Ref.)	D1 (max.)				D2	Pump	Motor				Pump/Motor			
		ODP 1Ø	TEFC 1Ø	ODP 3Ø		TEFC 3Ø	ODP 1Ø	TEFC 1Ø	ODP 3Ø						TEFC 3Ø	ODP 1Ø	TEFC 1Ø	ODP 3Ø			TEFC 3Ø	ODP 1Ø	TEFC 1Ø	ODP 3Ø	TEFC 3Ø	ODP 1Ø	TEFC 1Ø	ODP 3Ø
10SV-02	5	184TC	182TC	184TC	17.06	13.93	15.43	12.55	13.93	-	-	16.67	16.67	6.87	8.88	8.86	9.02	8.86	5.51	41	81	92	62	69	122	133	103	110
10SV-03					18.32	13.93	15.43	12.55	13.93	-	-	17.93	17.93	6.87	8.88	8.86	9.02	8.86	5.51	43	81	92	62	69	124	135	105	112
10SV-04					19.58	13.93	15.43	12.55	13.93	-	-	19.19	19.19	6.87	8.88	8.86	9.02	8.86	5.51	46	81	92	62	69	127	138	108	115
10SV-05	7.5	213TC	184TC	20.84	13.88	15.53	13.93	15.43	20.84	10.20	20.45	20.45	8.05	8.89	10.62	8.88	8.86	5.51	48	100	120	75	85	148	168	123	133	
10SV-06				22.10	13.88	15.53	13.93	15.43	22.10	11.46	21.71	21.71	8.05	8.89	10.62	8.88	8.86	5.51	50	100	120	75	85	150	170	125	135	
10SV-07				23.36	13.88	15.53	13.93	15.43	23.36	12.72	22.97	22.97	8.05	8.89	10.62	8.88	8.86	5.51	52	100	120	75	85	152	172	127	137	
10SV-08	10	215TC	213TC	215TC	25.19	16.63	16.68	15.55	15.51	25.19	13.98	24.79	24.79	8.77	10.62	10.18	10.18	10.28	5.51	61	132	145	107	122	193	206	168	183
10SV-09					26.45	16.63	16.68	15.55	15.51	26.45	15.24	26.05	26.05	8.77	10.62	10.18	10.18	10.28	5.51	63	132	145	107	122	195	208	170	185
10SV-10					27.71	16.63	16.68	15.55	15.51	27.71	16.50	-	27.31	8.77	10.62	10.18	10.18	10.28	5.51	66	132	145	107	122	198	211	173	188
10SV-11	15	-	215TC	254TC	29.60	-	-	15.55	16.57	29.60	17.76	-	29.20	9.22	-	-	10.18	10.28	5.51	73	-	-	125	195	-	-	198	268
10SV-12					30.07	-	-	15.55	16.57	30.07	19.02	-	29.68	9.22	-	-	10.18	10.28	5.51	75	-	-	125	195	-	-	200	270
10SV-13					32.14	-	-	15.55	16.57	32.14	20.28	-	31.74	9.22	-	-	10.18	10.28	5.51	80	-	-	125	195	-	-	205	275
10SV-14					33.48	-	-	15.55	16.57	33.48	21.54	-	33.08	9.22	-	-	10.18	10.28	5.51	82	-	-	125	195	-	-	207	277
10SV-15					34.66	-	-	15.55	16.57	-	-	-	34.26	9.22	-	-	10.18	10.28	5.51	84	-	-	125	195	-	-	209	279
10SV-16					35.92	-	-	15.55	16.57	-	-	-	35.52	9.22	-	-	10.18	10.28	5.51	86	-	-	125	195	-	-	211	281
10SV-17					37.18	-	-	15.55	16.57	-	-	-	36.78	9.22	-	-	10.18	10.28	5.51	88	-	-	125	195	-	-	213	283
10SV-18	20	-	254TC	256TC	38.44	-	-	16.66	20.08	-	-	-	38.04	9.5	-	-	10.18	13.13	5.51	90	-	-	144	285	-	-	234	375
10SV-19					39.78	-	-	16.66	20.08	-	-	-	39.38	9.5	-	-	10.18	13.13	5.51	92	-	-	144	285	-	-	236	377
10SV-20					40.96	-	-	16.66	20.08	-	-	-	40.56	9.5	-	-	10.18	13.13	5.51	94	-	-	144	285	-	-	238	379

Performance Curve

10SV 60 Hz 3500 RPM

LOW NPSH CURVE

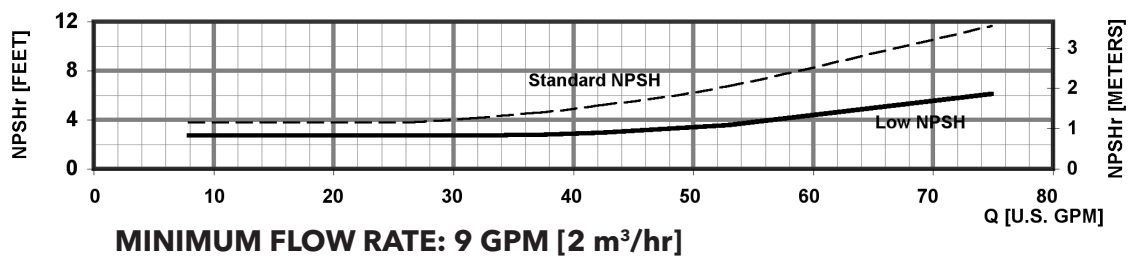
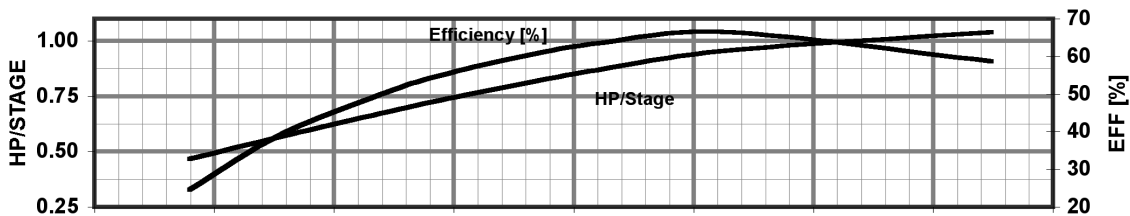
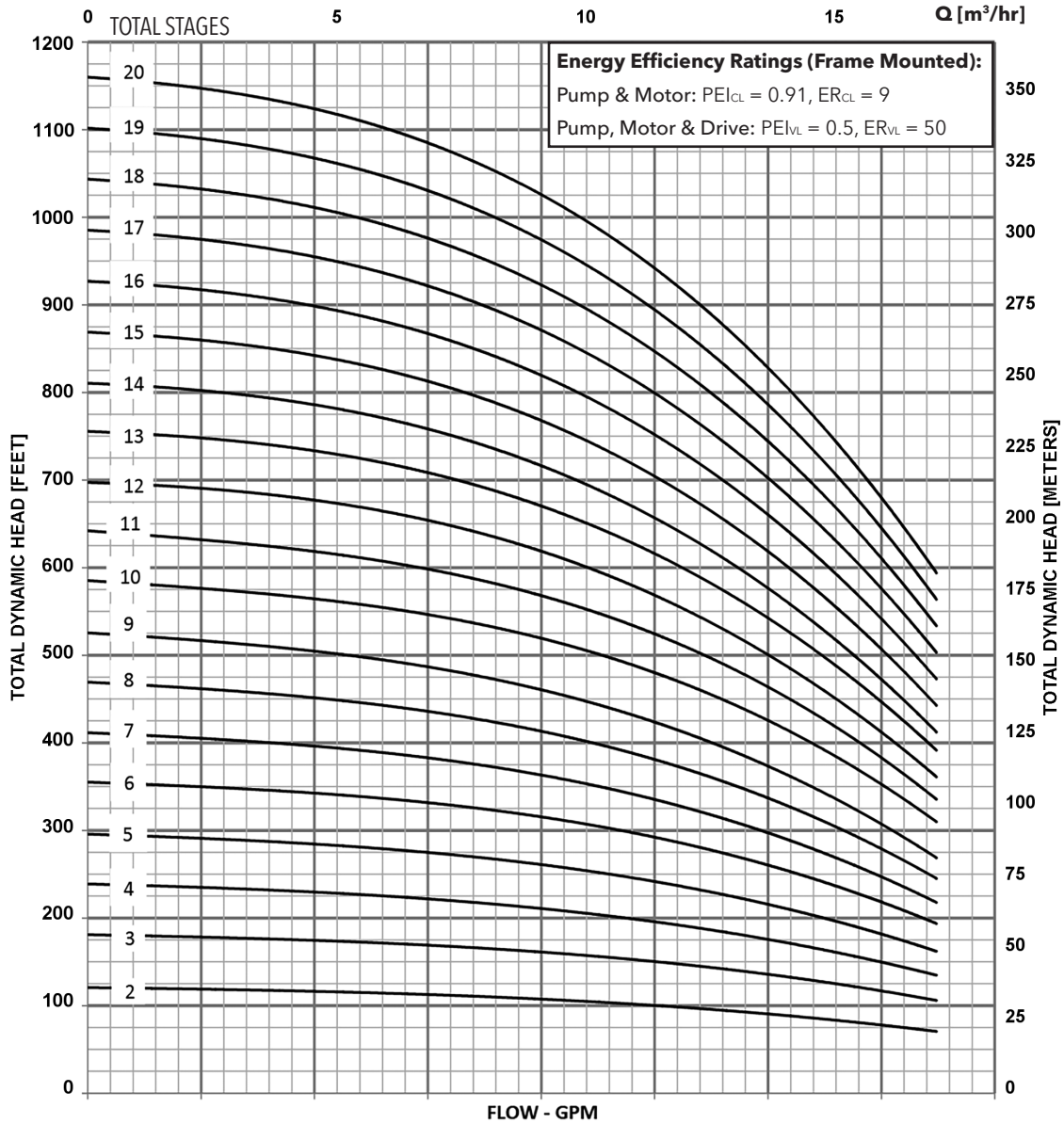

MINIMUM FLOW RATE: 9 GPM [2 m³/hr]

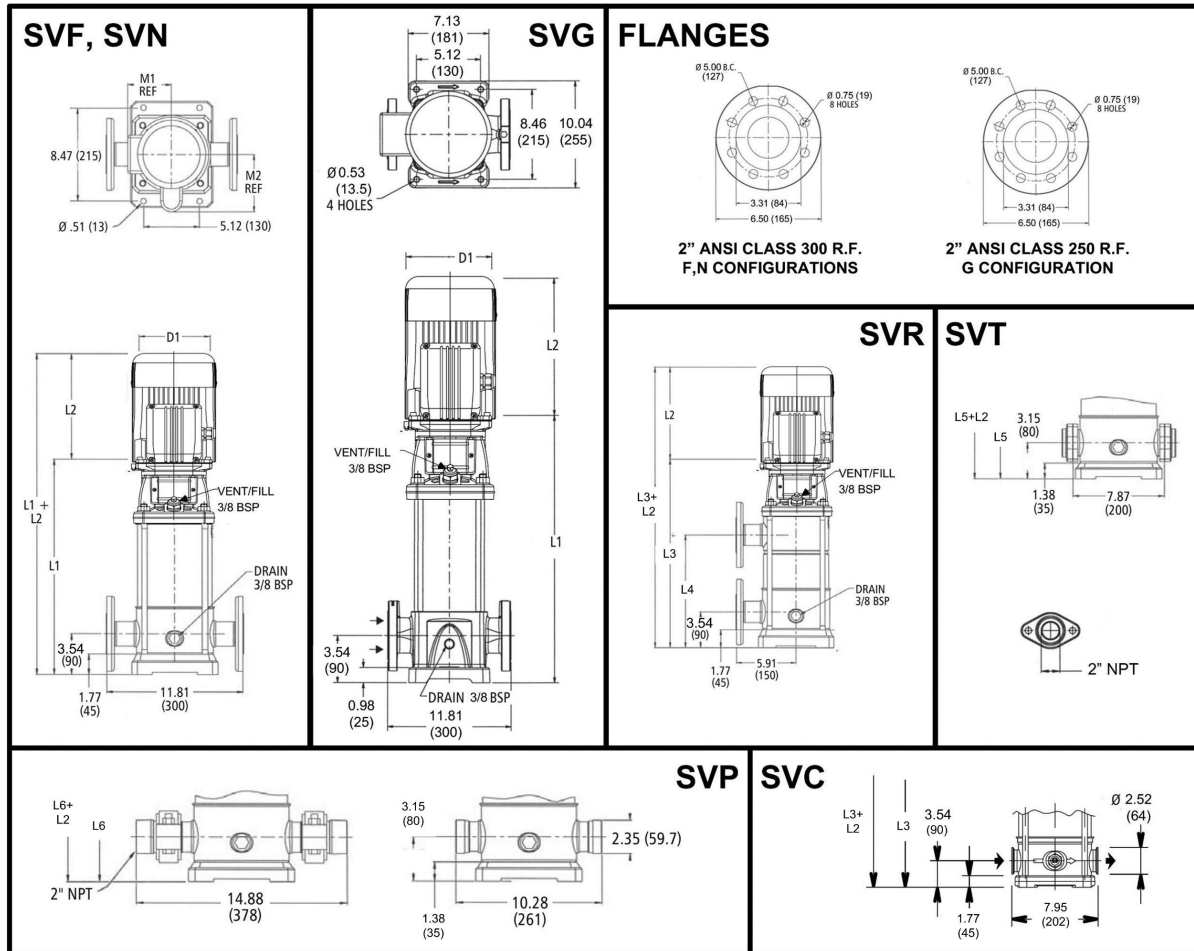

All dimensions are in inches (mm).

PUMP DIMENSIONS AND WEIGHTS - 15SV SERIES – 60Hz, 3500 RPM ODP/TEFC Enclosures

Pump Type Stages	HP	Motor				Dimensions (in)													Weight (lbs.)										
		NEMA Frame				L1	L2				L3	L4	L5	L6	M (Ref.)	D1 (max.)				D2	Pump	Motor				Pump/Motor			
		ODP 1Ø	TEFC 1Ø	ODP 3Ø	TEFC 3Ø		ODP 1Ø	TEFC 1Ø	ODP 3Ø	TEFC 3Ø						ODP 1Ø	TEFC 1Ø	ODP 3Ø	TEFC 3Ø			ODP 1Ø	TEFC 1Ø	ODP 3Ø	TEFC 3Ø	ODP 1Ø	TEFC 1Ø	ODP 3Ø	TEFC 3Ø
15SV-02	5	184TC	182TC	184TC	18.71	13.93	15.43	12.55	13.93	-	-	18.32	18.32	6.87	8.88	8.86	9.02	8.86	5.51	44	81	92	62	69	125	136	106	113	
15SV-03	7.5	213TC	184TC		20.60	13.88	15.53	13.93	15.43	-	-	20.21	20.21	8.05	8.89	10.62	8.88	8.86	5.51	47	100	120	75	85	147	167	122	132	
15SV-04	10	215TC	213TC	215TC	23.06	16.63	16.68	15.55	15.51	23.06	11.85	22.67	22.67	8.77	10.62	10.18	10.18	10.28	5.51	57	132	145	107	122	189	202	164	179	
15SV-05					24.95	16.63	16.68	15.55	15.51	24.95	13.74	24.56	8.77	10.62	10.18	10.18	10.28	5.51	59	132	145	107	122	191	204	166	181		
15SV-06	15	215TC	254TC	254TC	27.49	-	-	15.55	16.57	27.49	15.63	27.10	27.10	9.22	-	-	10.18	10.28	5.51	71	-	-	125	195	-	-	196	266	
15SV-07					29.38	-	-	15.55	16.57	29.38	17.52	28.99	28.99	9.22	-	-	10.18	10.28	5.51	74	-	-	125	195	-	-	199	269	
15SV-08					31.27	-	-	15.55	16.57	31.27	19.41	-	30.88	9.22	-	-	10.18	10.28	5.51	76	-	-	125	195	-	-	201	271	
15SV-09					33.16	-	-	16.66	20.08	33.16	21.30	-	32.77	9.5	-	-	10.18	13.13	5.51	79	-	-	144	285	-	-	223	364	
15SV-10	20	254TC	256TC	256TC	35.05	-	-	16.66	20.08	35.05	23.19	-	34.66	9.5	-	-	10.18	13.13	5.51	83	-	-	144	285	-	-	227	368	
15SV-11					36.94	-	-	16.66	20.08	36.94	25.08	-	36.55	9.5	-	-	10.18	13.13	5.51	86	-	-	144	285	-	-	230	371	
15SV-12					39.46	-	-	21.44	19.54	-	-	-	39.07	12.94	-	-	11.63	12.94	5.51	97	-	-	185	283	-	-	282	380	
15SV-13	25	254TC	284TC	284TC	41.35	-	-	21.44	19.54	-	-	-	40.96	12.94	-	-	11.63	12.94	5.51	100	-	-	185	283	-	-	285	383	
15SV-14					43.24	-	-	21.44	19.54	-	-	-	42.85	12.94	-	-	11.63	12.94	5.51	103	-	-	185	283	-	-	288	386	
15SV-15					45.13	-	-	21.75	19.54	-	-	-	44.74	12.21	-	-	13.25	12.94	5.51	106	-	-	296	382	-	-	402	488	

Performance Curve

15SV 60 Hz 3500 RPM

LOW NPSH CURVE

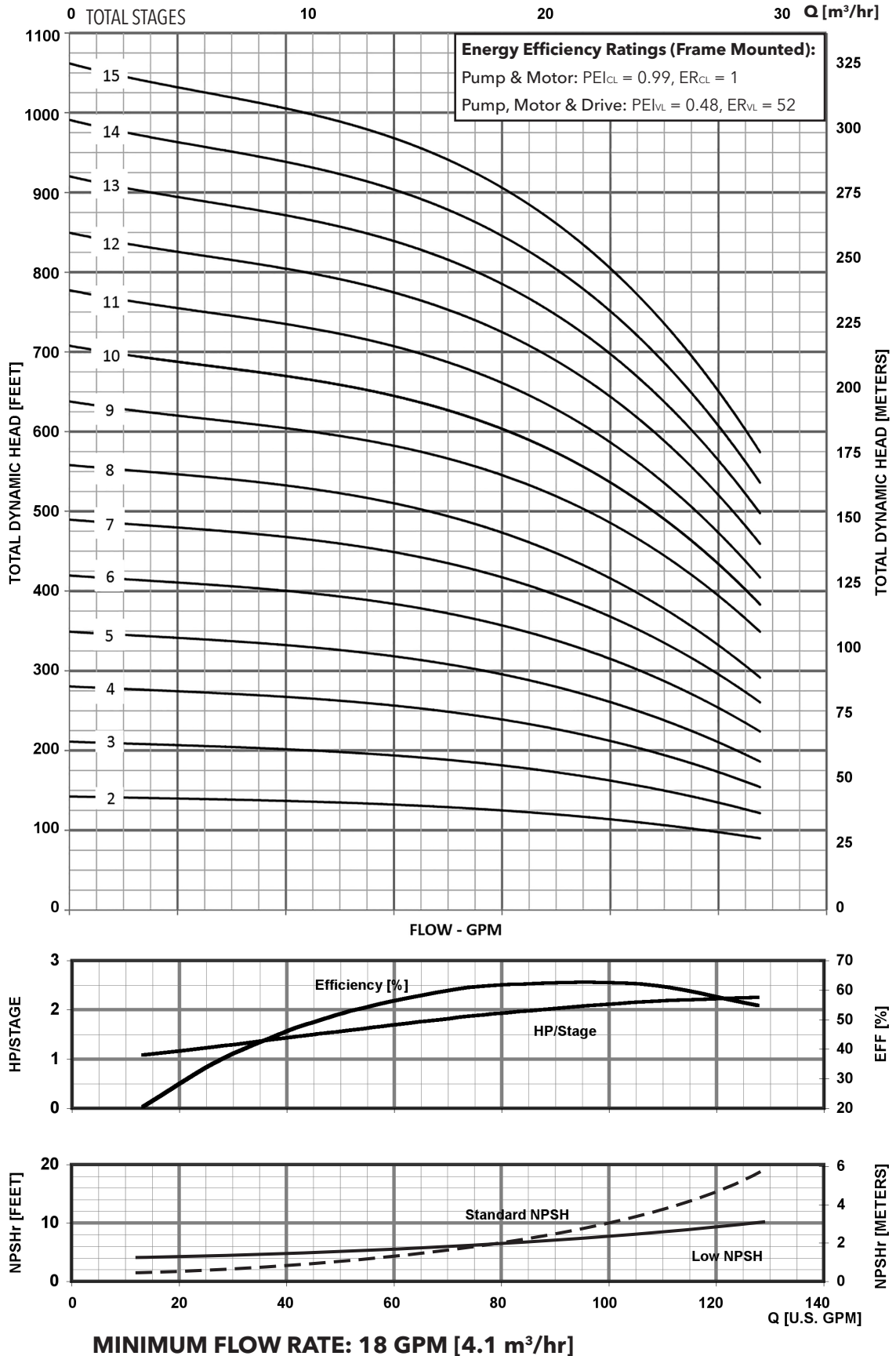

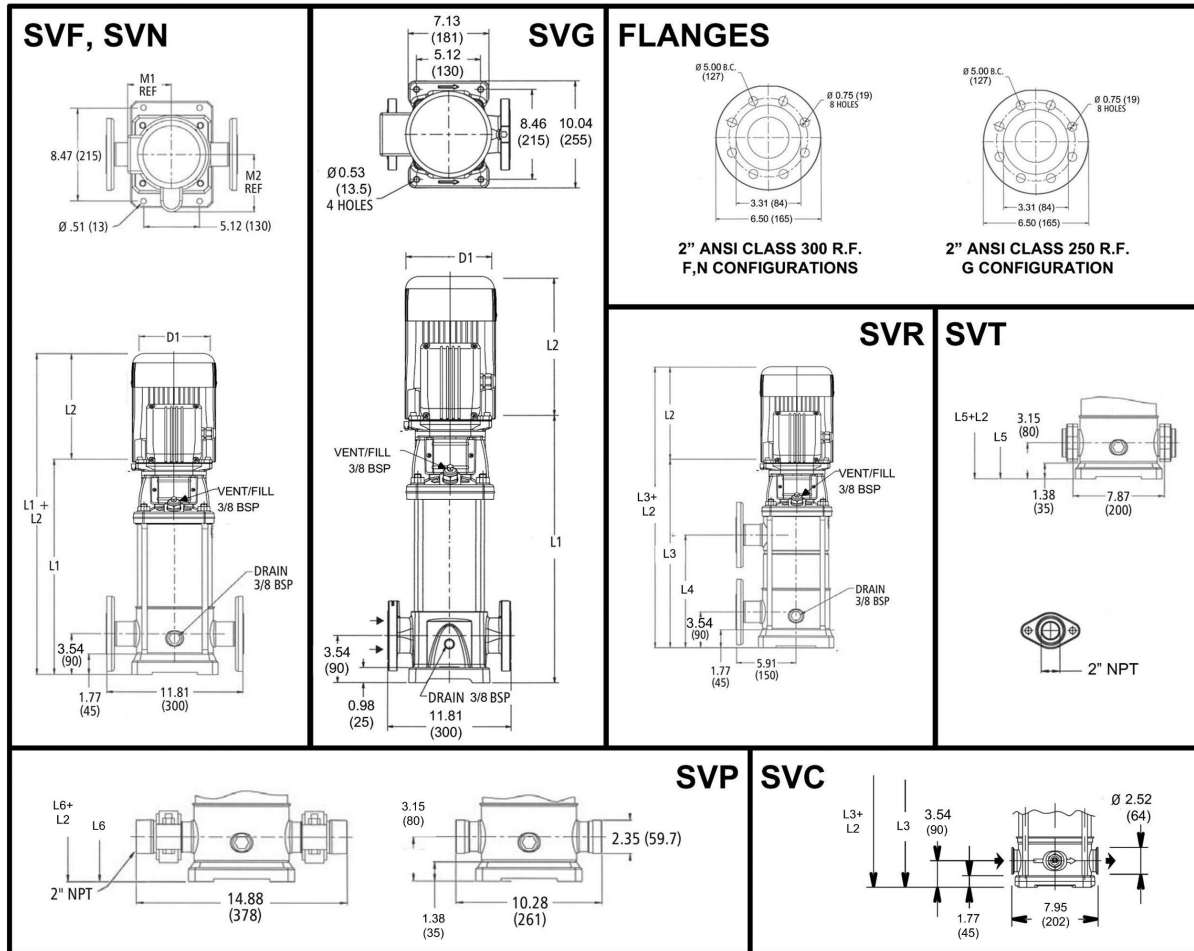

All dimensions are in inches (mm).

PUMP DIMENSIONS AND WEIGHTS - 22SV SERIES – 60Hz, 3500 RPM ODP/TEFC Enclosures

Pump Type Stages	HP	Motor				Dimensions (in)											Weight (lbs.)											
		NEMA Frame				L2				L3			D1 (max.)				D2	Pump	Motor				Pump/Motor					
		ODP 1Ø	TEFC 1Ø	ODP 3Ø	TEFC 3Ø	L1	ODP 1Ø	TEFC 1Ø	ODP 3Ø	TEFC 3Ø	L4	L5	L6	M (Ref.)	ODP 1Ø	TEFC 1Ø			ODP 3Ø	TEFC 3Ø	ODP 1Ø	TEFC 1Ø	ODP 3Ø	TEFC 3Ø				
22SV-02	7.5	213TC	184TC	184TC	18.71	13.88	15.53	13.93	15.43	18.71	-	18.32	18.32	8.05	8.89	10.62	8.88	8.86	5.51	45	100	120	75	85	145	165	120	130
22SV-03	10	215TC	213TC	215TC	21.17	16.63	16.68	15.55	15.51	21.17	-	20.78	20.78	8.77	10.62	10.18	10.18	10.28	5.51	55	132	145	107	122	187	200	162	177
22SV-04		23.06			16.63	16.68	15.55	15.51	23.06	11.85	22.67	22.67	8.77	10.62	10.18	10.18	10.28	5.51	58	132	145	107	122	190	203	165	180	
22SV-05	15		215TC		25.60	-	-	15.55	16.57	25.60	13.74	25.21	25.21	9.22	-	-	10.18	10.28	5.51	66	-	-	125	195	-	-	191	261
22SV-06					27.49	-	-	15.55	16.57	27.49	15.63	27.10	27.10	9.22	-	-	10.18	10.28	5.51	69	-	-	125	195	-	-	194	264
22SV-07	20		254TC		29.38	-	-	16.66	20.08	29.38	17.52	28.99	28.99	9.5	-	-	10.18	13.13	5.51	72	-	-	144	285	-	-	216	357
22SV-08					31.27	-	-	16.66	20.08	31.27	19.41	-	30.88	9.5	-	-	10.18	13.13	5.51	75	-	-	144	285	-	-	219	360
22SV-09					33.16	-	-	16.66	20.08	33.16	21.30	-	32.77	9.5	-	-	10.18	13.13	5.51	77	-	-	144	285	-	-	221	362
22SV-10	25		254TC	284TC	35.68	-	-	21.44	19.54	35.68	23.19	-	35.29	12.94	-	-	11.63	12.94	5.51	89	-	-	185	283	-	-	274	372
22SV-11					37.57	-	-	21.44	19.54	37.57	25.08	-	37.18	12.94	-	-	11.63	12.94	5.51	92	-	-	185	283	-	-	277	375
22SV-12					30	284TC	286TC	39.46	-	-	21.75	19.54	-	-	-	39.07	12.21	-	-	13.25	12.94	5.51	95	-	-	296	382	-

Performance Curve

22SV 60 Hz 3500 RPM

LOW NPSH CURVE

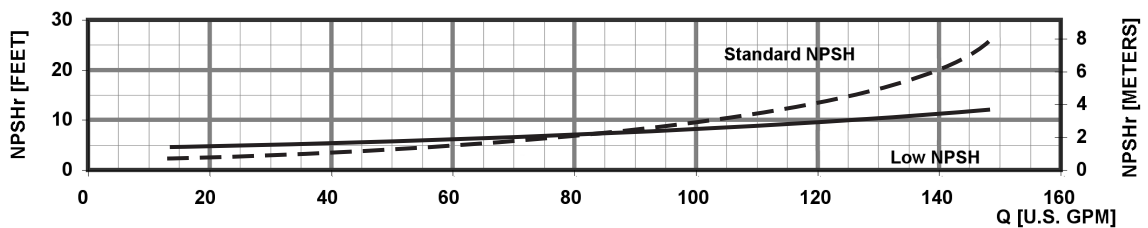
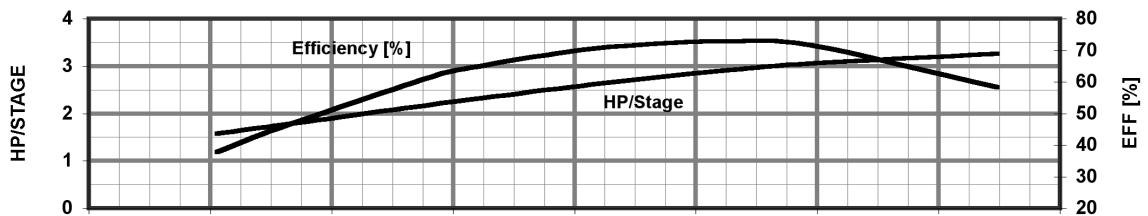
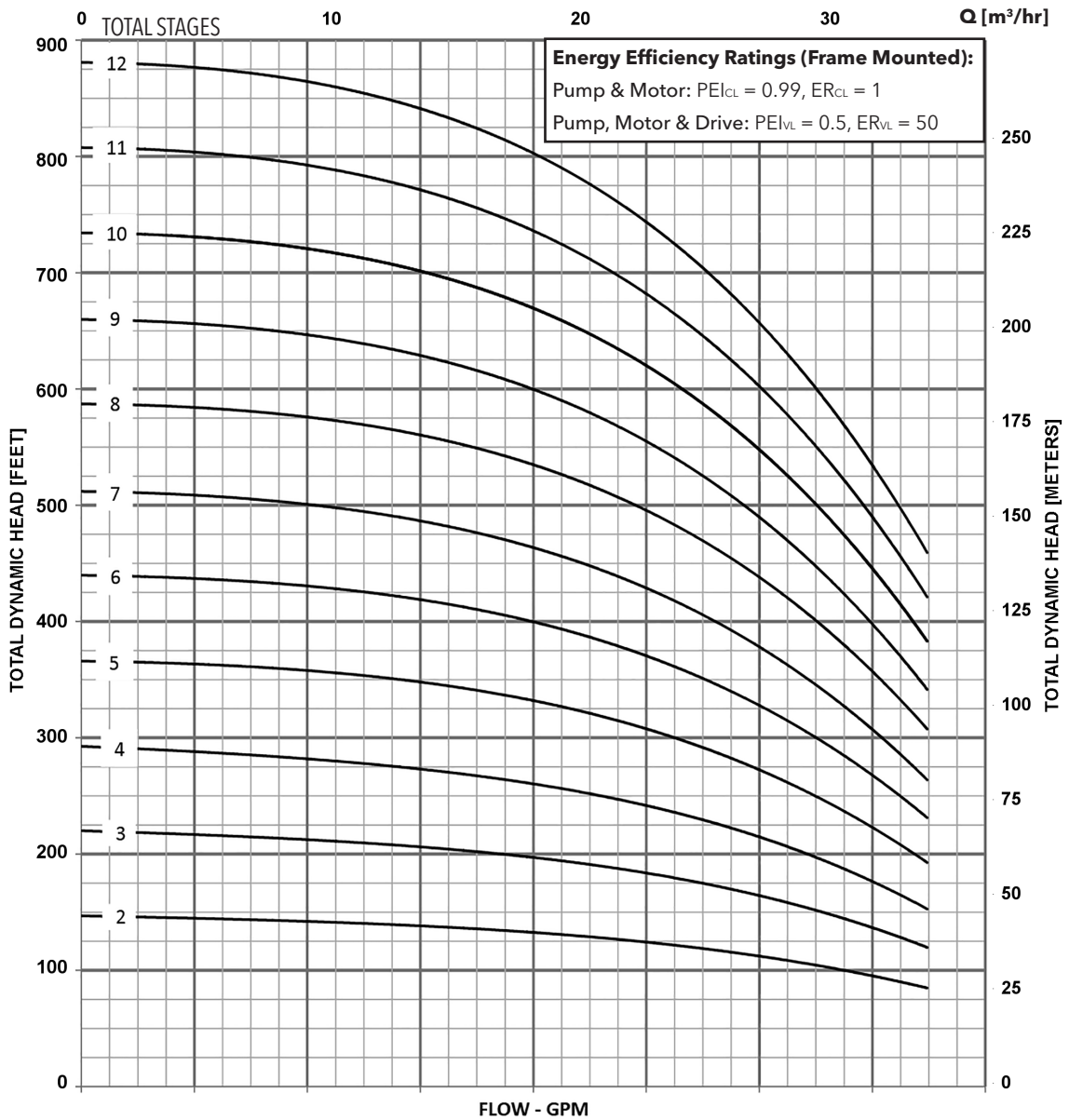

MINIMUM FLOW RATE: 21 GPM [4.8 m³/hr]

Dimensions and Weights

33SV Series 3500 RPM

LOW NPSH

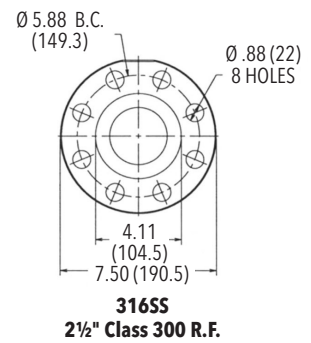
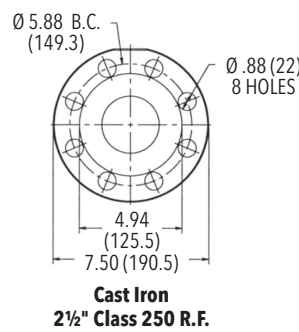
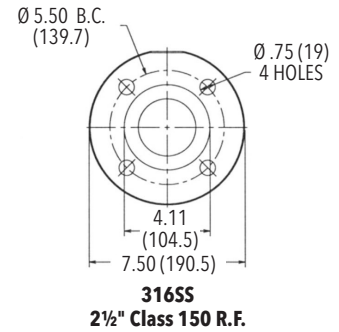
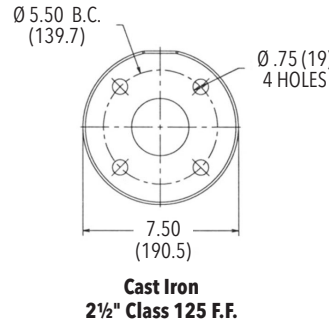
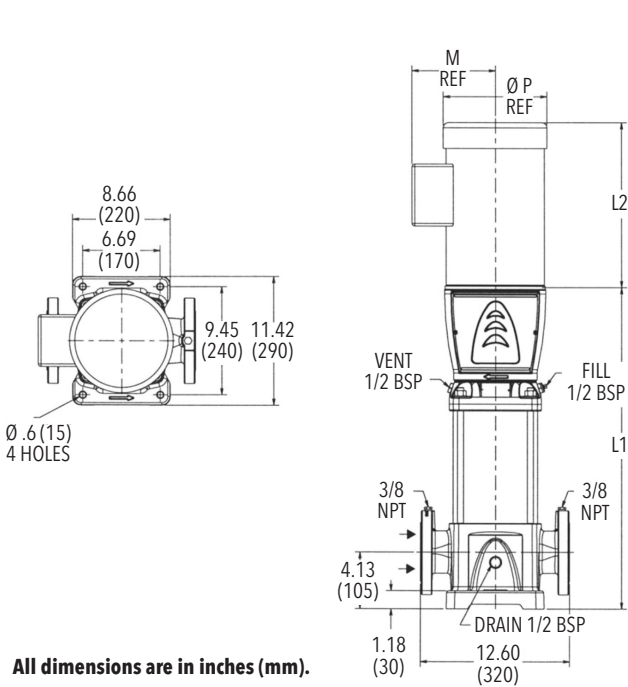

PUMP DIMENSIONS AND WEIGHTS - 33SV SERIES – 60Hz, 3500 RPM ODP/TEFC Enclosures

Pump Type Stages	Motor				Dimensions (in)										Weight (lbs.)										
	HP	NEMA Frame		L1	L2				M (Ref.)	D1 (max.)				D2	Pump Only	Motor				Pump/Motor					
		ODP 1Ø	TEFC 1Ø		ODP 3Ø	TEFC 3Ø	ODP 1Ø	TEFC 1Ø		ODP 3Ø	TEFC 3Ø	ODP 1Ø	TEFC 1Ø			ODP 3Ø	TEFC 3Ø	ODP 1Ø	TEFC 1Ø	ODP 3Ø	TEFC 3Ø	ODP 1Ø	TEFC 1Ø	ODP 3Ø	TEFC 3Ø
33SV-2/1	10	215TC	213TC	215TC	23.58	16.63	16.68	15.55	15.51	8.77	10.62	10.18	10.18	10.28	5.51181	143	132	145	107	122	275	288	250	265	
33SV-2					23.58	16.63	16.68	15.55	15.51	8.77	10.62	10.18	10.18	10.28	5.51181	143	132	145	107	122	275	288	250	265	
33SV-3/2	15	-	215TC	254TC	26.54	-	-	15.55	16.57	9.22	-	-	10.18	10.28	5.51181	152	-	-	125	195	-	-	277	347	
33SV-3/1					26.54	-	-	15.55	16.57	9.22	-	-	10.18	10.28	5.51181	152	-	-	125	195	-	-	277	347	
33SV-3					26.54	-	-	16.66	20.08	9.5	-	-	10.18	13.13	5.51181	152	-	-	144	285	-	-	296	371	469
33SV-4/2					29.50	-	-	16.66	20.08	9.5	-	-	10.18	13.13	5.51181	161	-	-	144	285	-	-	305	446	
33SV-4/1	20	-	254TC	256TC	29.50	-	-	16.66	20.08	9.5	-	-	10.18	13.13	5.51181	161	-	-	144	285	-	-	305	446	
33SV-4					29.50	-	-	21.44	19.54	12.94	-	-	11.63	12.94	5.51181	161	-	-	185	283	-	-	346	444	
33SV-5/2	25	-	254TC	284TC	32.44	-	-	21.44	19.54	12.94	-	-	11.63	12.94	5.51181	172	-	-	185	283	-	-	357	455	
33SV-5/1					32.44	-	-	21.44	19.54	12.94	-	-	11.63	12.94	5.51181	172	-	-	185	283	-	-	357	455	
33SV-5					32.44	-	-	21.44	19.54	12.94	-	-	11.63	12.94	5.51181	186	-	-	185	283	-	-	371	469	
33SV-6/2					35.40	-	-	21.75	19.54	12.21	-	-	13.25	12.94	5.51181	194	-	-	296	382	-	-	490	576	
33SV-6/1	30	-	284TC	286TC	35.40	-	-	21.75	19.54	12.21	-	-	13.25	12.94	5.51181	194	-	-	296	382	-	-	490	576	
33SV-6					35.40	-	-	21.75	23.18	13.11	-	-	13.25	15.56	5.51181	194	-	-	315	446	-	-	509	640	
33SV-7/2	40	-	286TC	286TC	38.55	-	-	21.75	23.18	13.11	-	-	13.25	15.56	5.51181	204	-	-	315	446	-	-	519	650	
33SV-7/1					38.55	-	-	21.75	23.18	13.11	-	-	13.25	15.56	5.51181	204	-	-	315	446	-	-	519	650	
33SV-7					38.55	-	-	21.75	23.18	13.11	-	-	13.25	15.56	5.51181	204	-	-	315	446	-	-	519	650	
33SV-8/2					41.30	-	-	21.75	23.18	13.11	-	-	13.25	15.56	5.51181	221	-	-	315	446	-	-	536	667	
33SV-8/1	50	-	324TSC	326TSC	41.30	-	-	21.75	23.18	13.11	-	-	13.25	15.56	5.51181	229	-	-	315	446	-	-	544	675	
33SV-8					41.30	-	-	21.75	23.18	13.11	-	-	13.25	15.56	5.51181	229	-	-	315	446	-	-	544	675	
33SV-9/2	50	-	324TSC	326TSC	44.25	-	-	22.75	23.19	12.21	-	-	13.03	15.69	5.51	238	-	-	320	450	-	-	558	688	
33SV-9/1					44.25	-	-	22.75	23.19	12.21	-	-	13.03	15.69	5.51	238	-	-	320	450	-	-	558	688	
33SV-9					44.25	-	-	22.75	23.19	12.21	-	-	13.03	15.69	5.51	238	-	-	320	450	-	-	558	688	
33SV-10/2					47.20	-	-	22.75	23.19	12.21	-	-	13.03	15.69	5.51	249	-	-	320	450	-	-	569	699	
33SV-10/1					47.20	-	-	22.75	23.19	12.21	-	-	13.03	15.69	5.51	249	-	-	320	450	-	-	569	699	
33SV-10					47.20	-	-	22.75	23.19	12.21	-	-	13.03	15.69	5.51	249	-	-	320	450	-	-	569	699	

Performance Curve

33SV 60 Hz 3500 RPM

LOW NPSH CURVE

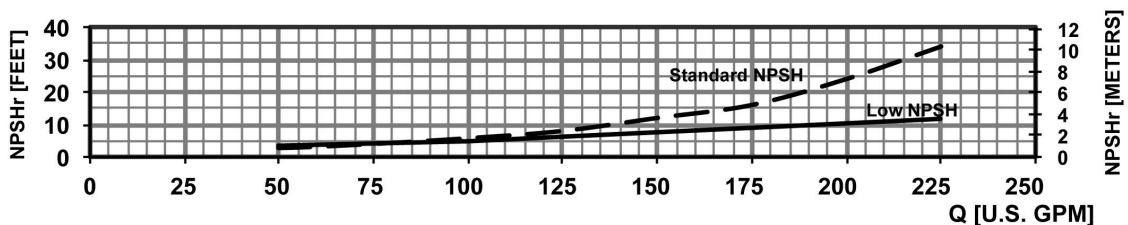
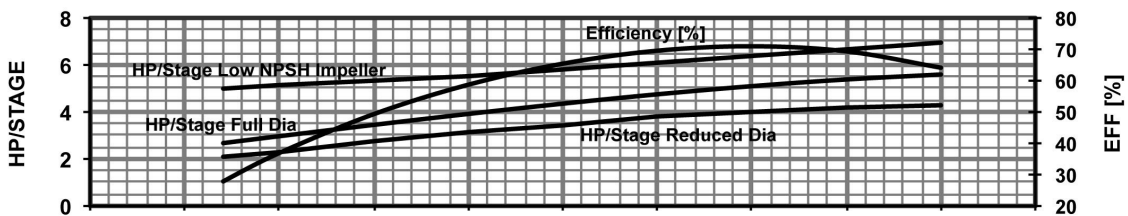
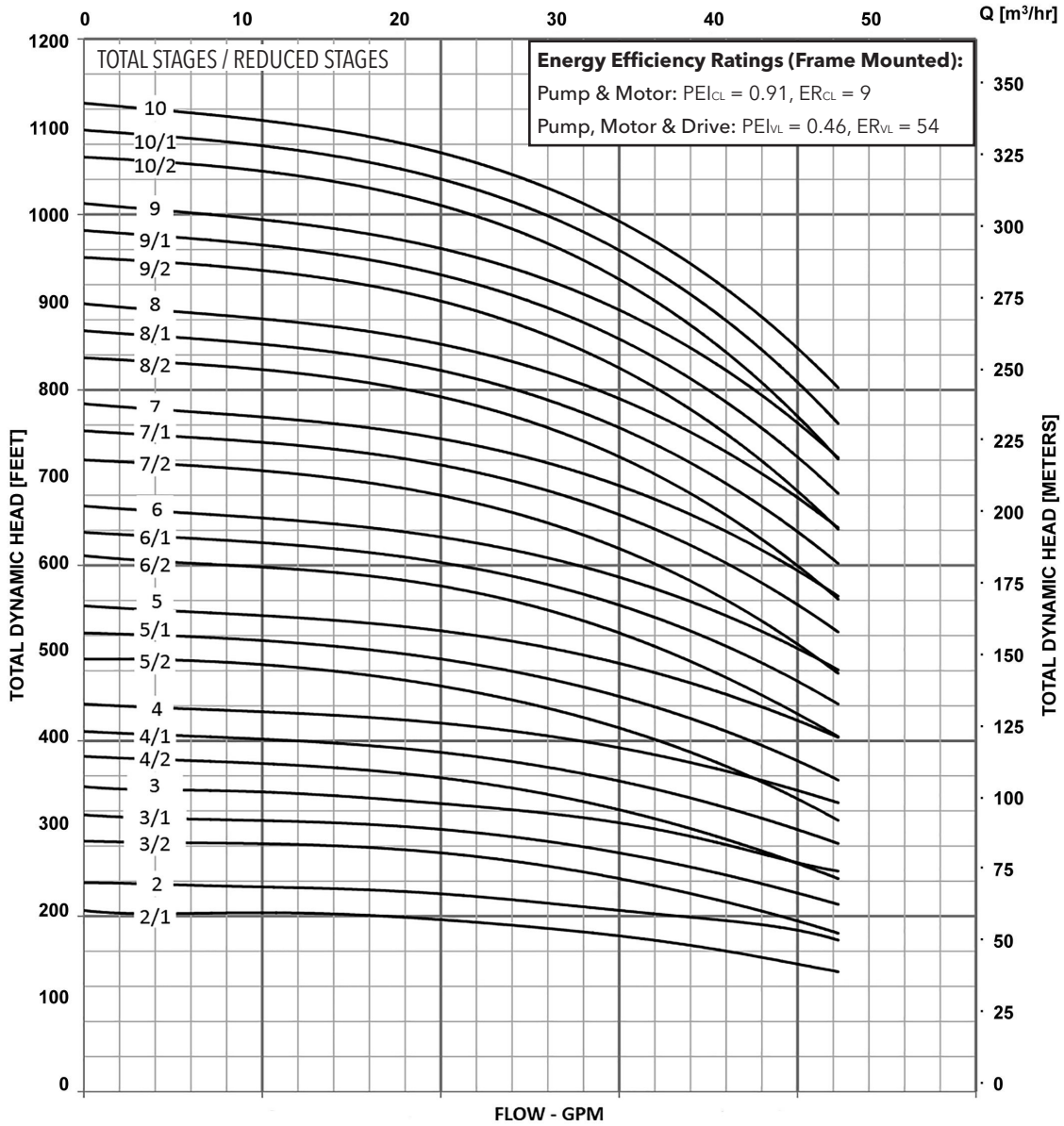

MINIMUM FLOW RATE: 35 GPM [8 m³/hr]

Dimensions and Weights

46SV Series 3500 RPM

LOW NPSH

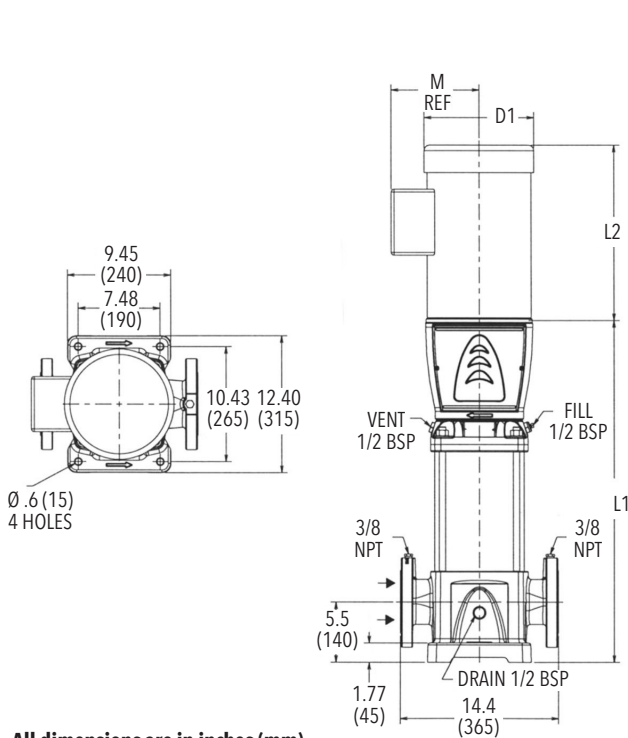

All dimensions are in inches (mm).

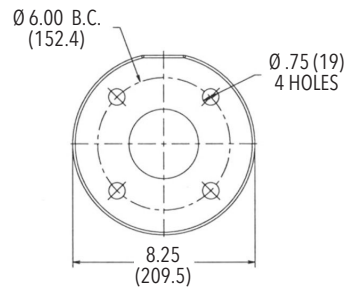

Cast Iron
3" Class 125 R.F.

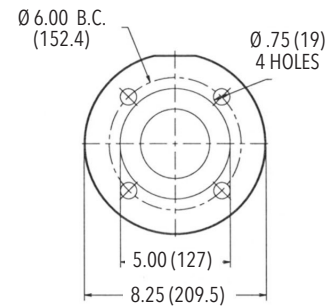

316SS
3" Class 150 R.F.

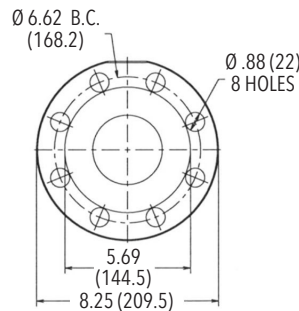

Cast Iron
3" Class 250 R.F.

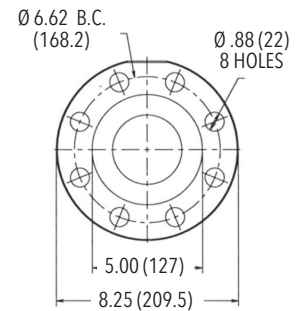

316SS
3" Class 300 R.F.

PUMP DIMENSIONS AND WEIGHTS - 46SV SERIES – 60Hz, 3500 RPM ODP/TEFC Enclosures

Pump Type Stages	Motor				Dimensions (in)										Weight (lbs.)										
	HP	NEMA Frame			L1	L2				M (Ref.)	D1 (max.)				D2	Pump Only	Motor				Pump/Motor				
		ODP 1Ø	TEFC 1Ø	ODP 3Ø		TEFC 3Ø	ODP 1Ø	TEFC 1Ø	ODP 3Ø		TEFC 3Ø	ODP 1Ø	TEFC 1Ø	ODP 3Ø			TEFC 3Ø	ODP 1Ø	TEFC 1Ø	ODP 3Ø	TEFC 3Ø	ODP 1Ø	TEFC 1Ø	ODP 3Ø	TEFC 3Ø
46SV-2/1	15	-	-	215TC	254TC	25.19	-	-	15.55	16.57	9.22	-	-	10.18	10.28	5.51	158	-	-	125	195	-	-	283	353
46SV-2	20	-	-	254TC	256TC	25.19	-	-	16.66	20.08	9.5	-	-	10.18	13.13	5.51	158	-	-	144	285	-	-	302	443
46SV-3/2		-	-	-	-	28.12	-	-	16.66	20.08	9.5	-	-	10.18	13.13	5.51	169	-	-	144	285	-	-	313	454
46SV-3/1	25	-	-	254TC	284TC	28.12	-	-	21.44	19.54	12.94	-	-	11.63	12.94	5.51	169	-	-	185	283	-	-	354	452
46SV-3		-	-	-	-	29.63	-	-	21.44	19.54	12.94	-	-	11.63	12.94	5.51	183	-	-	185	283	-	-	368	466
46SV-4/2	30	-	-	284TC	286TC	32.63	-	-	21.75	19.54	12.21	-	-	13.25	12.94	5.51	192	-	-	296	382	-	-	488	574
46SV-4/1		-	-	-	-	32.63	-	-	21.75	19.54	12.21	-	-	13.25	12.94	5.51	192	-	-	296	382	-	-	488	574
46SV-4	40	-	-	286TC	286TC	35.56	-	-	21.75	23.18	13.11	-	-	13.25	15.56	5.51	199	-	-	315	446	-	-	514	645
46SV-5/2		-	-	-	-	35.56	-	-	21.75	23.18	13.11	-	-	13.25	15.56	5.51	199	-	-	315	446	-	-	514	645
46SV-5/1	50	-	-	324TSC	326TSC	38.50	-	-	22.75	23.19	12.21	-	-	13.03	15.69	5.51	208	-	-	320	450	-	-	528	658
46SV-6/2		-	-	-	-	38.00	-	-	22.75	23.19	12.21	-	-	13.03	15.69	5.51	216	-	-	320	450	-	-	536	666
46SV-6/1	60	-	-	324TSC	326TSC	38.00	-	-	22.75	23.19	12.21	-	-	13.03	15.69	5.51	216	-	-	320	450	-	-	536	666
46SV-6		-	-	-	-	40.94	-	-	22.75	23.19	12.21	-	-	13.03	15.69	5.51	233	-	-	320	450	-	-	553	683
46SV-7/2	75	-	-	364TSC	365TSC	40.94	-	-	22.75	30.69	14.95	-	-	13.03	19.25	5.51	233	-	-	372	689	-	-	605	922
46SV-7		-	-	-	-	43.94	-	-	22.75	30.69	14.95	-	-	13.03	19.25	5.51	242	-	-	372	689	-	-	614	931
46SV-8/2	75	-	-	364TSC	365TSC	43.94	-	-	22.75	30.69	14.95	-	-	13.03	19.25	5.51	242	-	-	372	689	-	-	614	931
46SV-8/1		-	-	-	-	43.94	-	-	22.75	30.69	14.95	-	-	13.03	19.25	5.51	242	-	-	372	689	-	-	614	931
46SV-8	75	-	-	364TSC	365TSC	46.88	-	-	24.38	30.69	14.95	-	-	15.13	19.25	5.51	253	-	-	447	747	-	-	700	1000
46SV-9/2		-	-	-	-	46.88	-	-	24.38	30.69	14.95	-	-	15.13	19.25	5.51	253	-	-	447	747	-	-	700	1000
46SV-9/1	75	-	-	364TSC	365TSC	46.88	-	-	24.38	30.69	14.95	-	-	15.13	19.25	5.51	253	-	-	447	747	-	-	700	1000
46SV-9		-	-	-	-	49.81	-	-	24.38	30.69	14.95	-	-	15.13	19.25	5.51	264	-	-	447	747	-	-	711	1011
46SV-10/2		-	-																						

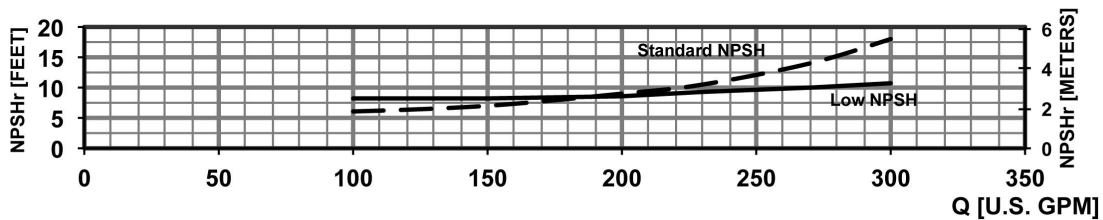
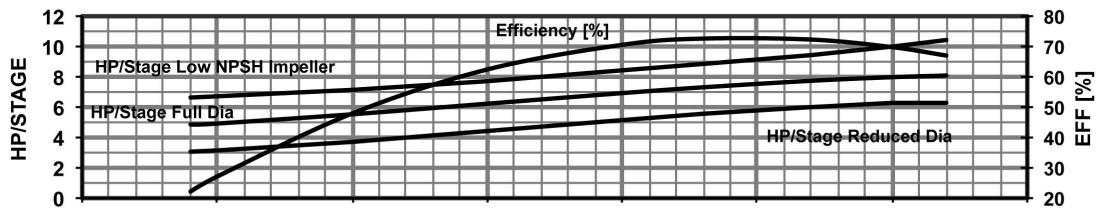
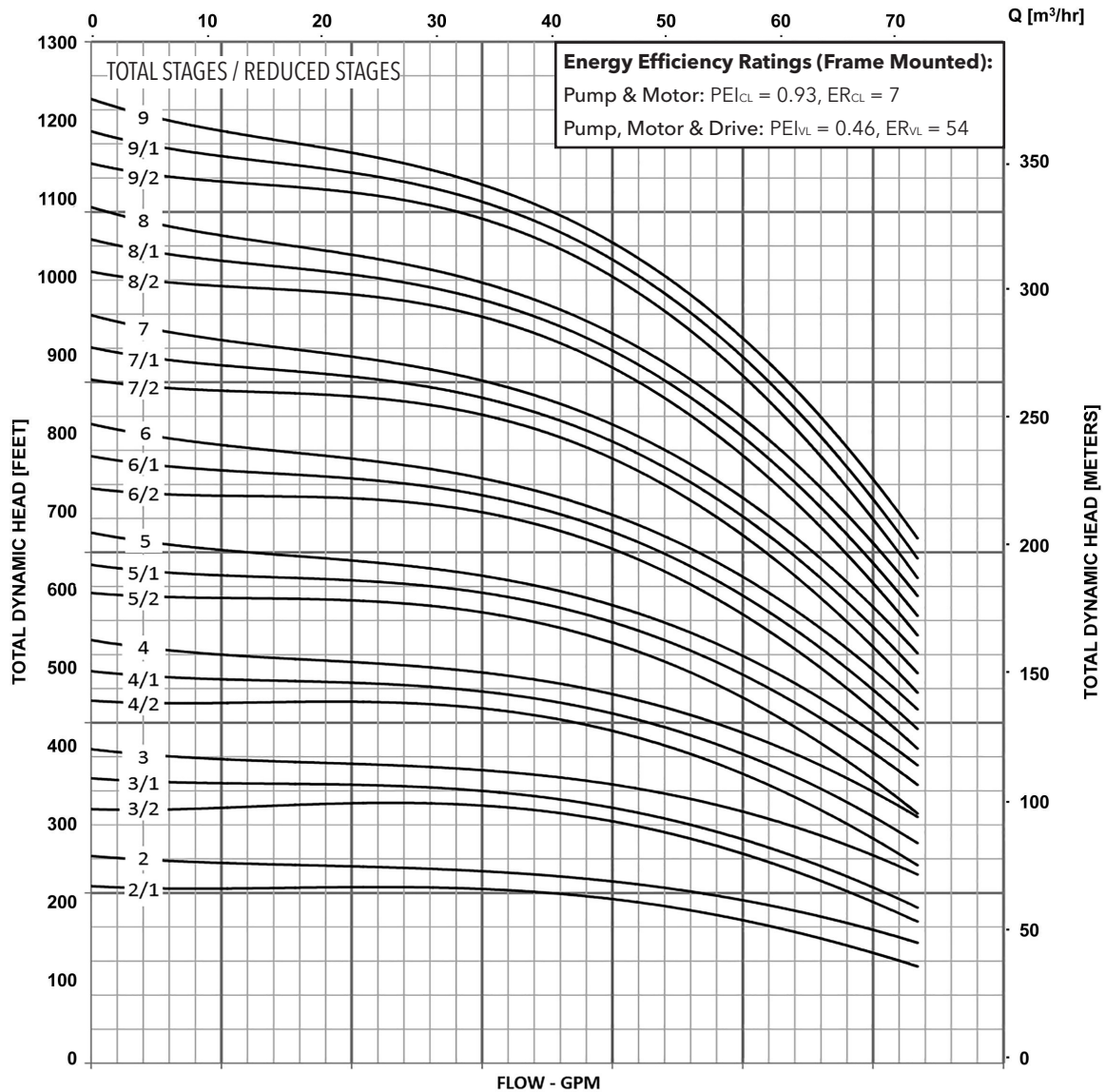

MINIMUM FLOW RATE: 40 GPM [9 m³/hr]

Dimensions and Weights

66SV Series 3500 RPM

LOW NPSH

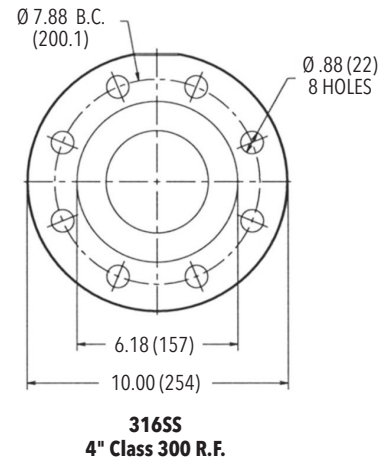
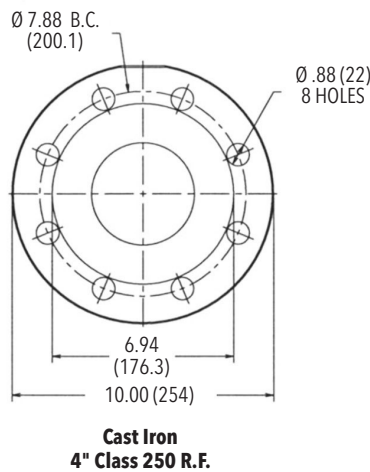
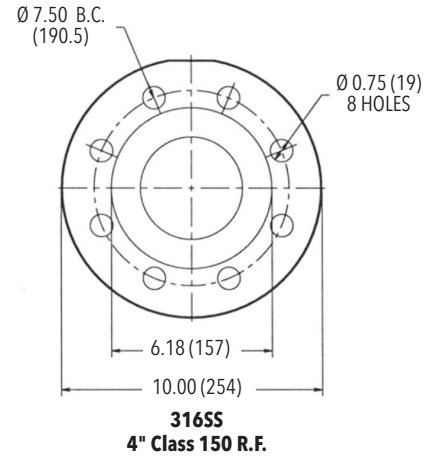
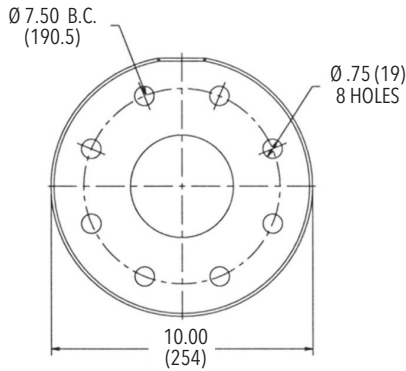
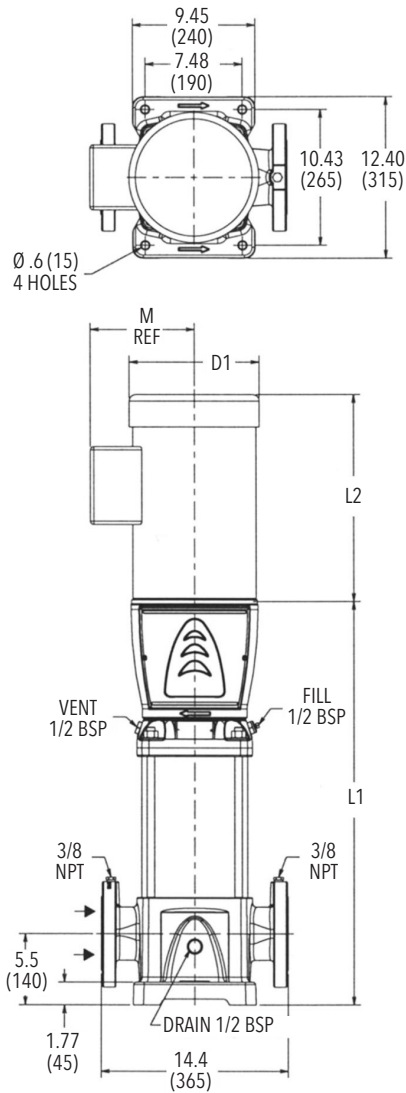

All dimensions are in inches (mm).

PUMP DIMENSIONS AND WEIGHTS - 66SV SERIES – 60Hz, 3500 RPM ODP/TEFC Enclosures

Pump Type Stages	Motor				Dimensions (in)											Weight (lbs.)									
	HP	NEMA Frame			L1	L2				M (Ref.)	D1 (max.)				D2	Pump Only	Motor				Pump/Motor				
		ODP 1Ø	TEFC 1Ø	ODP 3Ø		TEFC 3Ø	ODP 1Ø	TEFC 1Ø	ODP 3Ø		TEFC 3Ø	ODP 1Ø	TEFC 1Ø	ODP 3Ø			TEFC 3Ø	ODP 1Ø	TEFC 1Ø	ODP 3Ø	TEFC 3Ø	ODP 1Ø	TEFC 1Ø	ODP 3Ø	TEFC 3Ø
66SV-2/1	20	-	-	254TC	256TC	26.75	-	-	16.66	20.08	9.5	-	-	10.18	13.13	5.51	196	-	-	144	285	-	-	340	481
66SV-2	25	-	-	254TC	284TC	28.31	-	-	21.44	19.54	12.94	-	-	11.63	12.94	5.51	210	-	-	185	283	-	-	395	493
66SV-3/2	30	-	-	284TC	286TC	31.81	-	-	21.75	19.54	12.21	-	-	13.25	12.94	5.51	223	-	-	296	382	-	-	519	605
66SV-3/1		-	-			31.81	-	-	21.75	19.54	12.21	-	-	13.25	12.94	5.51	223	-	-	296	382	-	-	519	605
66SV-3	40	-	-	286TC	286TC	31.81	-	-	21.75	23.18	13.11	-	-	13.25	15.56	5.51	223	-	-	315	446	-	-	538	669
66SV-4/2		-	-			35.38	-	-	21.75	23.18	13.11	-	-	13.25	15.56	5.51	234	-	-	315	446	-	-	549	680
66SV-4/1	50	-	-	324TSC	326TSC	34.88	-	-	22.75	23.19	12.21	-	-	13.03	15.69	5.51	242	-	-	320	450	-	-	562	692
66SV-4		-	-			34.88	-	-	22.75	23.19	12.21	-	-	13.03	15.69	5.51	242	-	-	320	450	-	-	562	692
66SV-5/2		-	-			38.44	-	-	22.75	23.19	12.21	-	-	13.03	15.69	5.51	252	-	-	320	450	-	-	572	702
66SV-5/1	60	-	-	324TSC	326TSC	38.44	-	-	22.75	30.69	14.95	-	-	13.03	19.25	5.51	252	-	-	372	689	-	-	624	941
66SV-5		-	-			38.44	-	-	22.75	30.69	14.95	-	-	13.03	19.25	5.51	252	-	-	372	689	-	-	624	941
66SV-6/2		-	-			41.94	-	-	24.38	30.69	14.95	-	-	15.13	19.25	5.51	266	-	-	447	747	-	-	713	1013
66SV-6/1	75	-	-	364TSC	365TSC	41.94	-	-	24.38	30.69	14.95	-	-	15.13	19.25	5.51	266	-	-	447	747	-	-	713	1013
66SV-6		-	-			41.94	-	-	24.38	30.69	14.95	-	-	15.13	19.25	5.51	266	-	-	447	747	-	-	713	1013

Performance Curve

66SV 60 Hz 3500 RPM

LOW NPSH CURVE

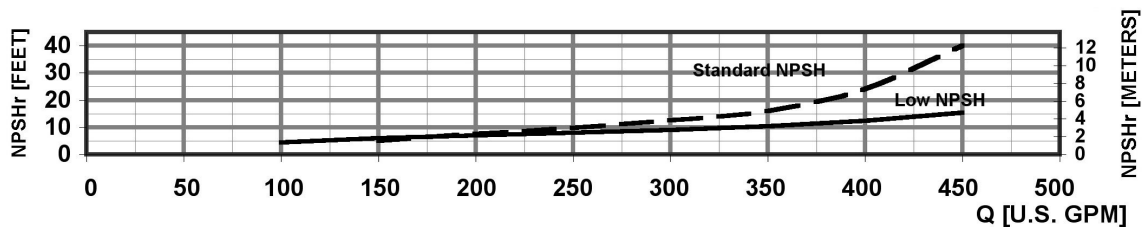
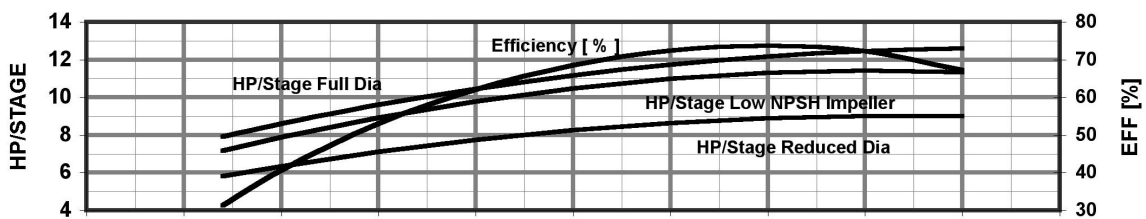
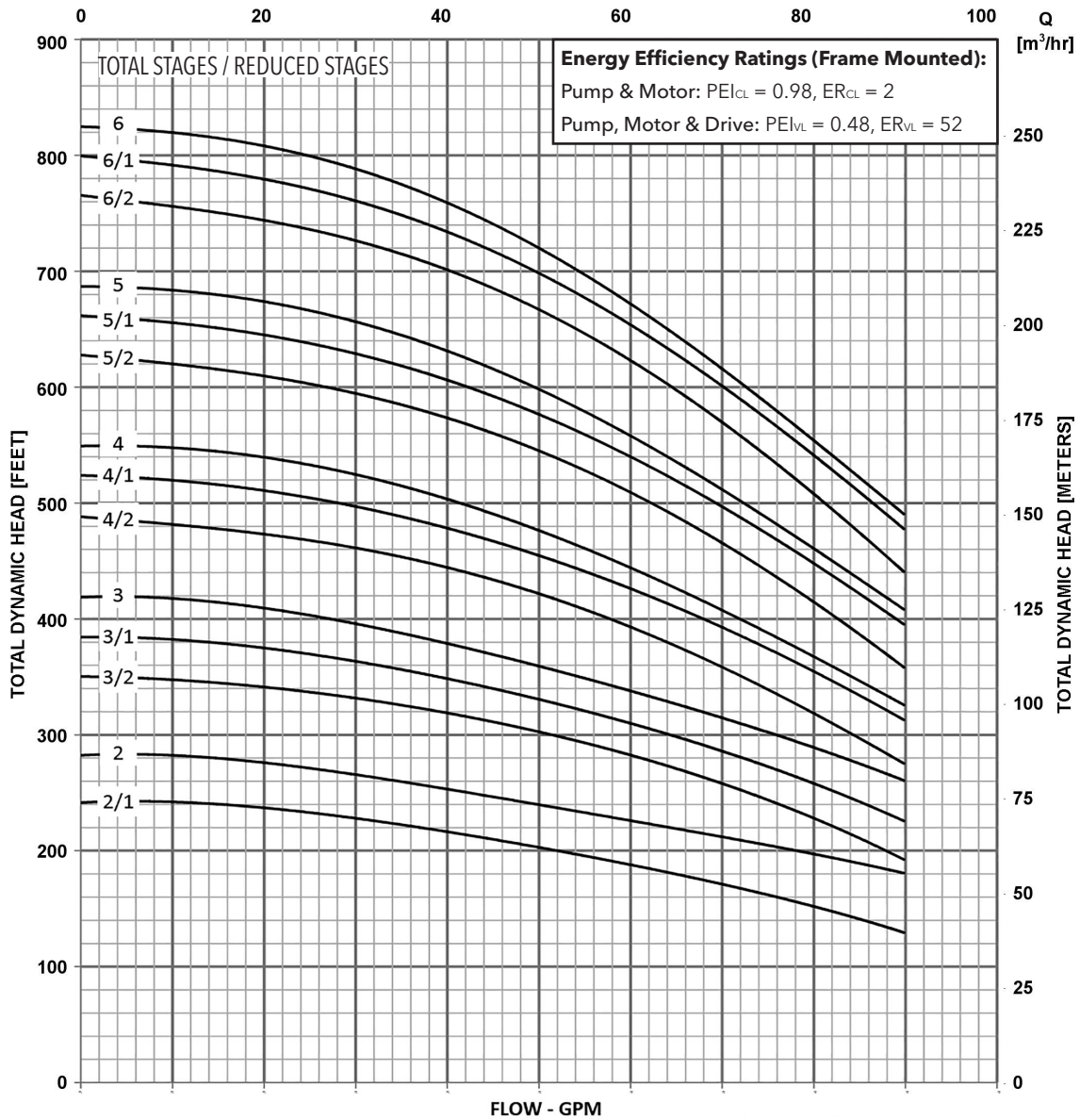

MINIMUM FLOW RATE: 70 GPM [16 m³/hr]

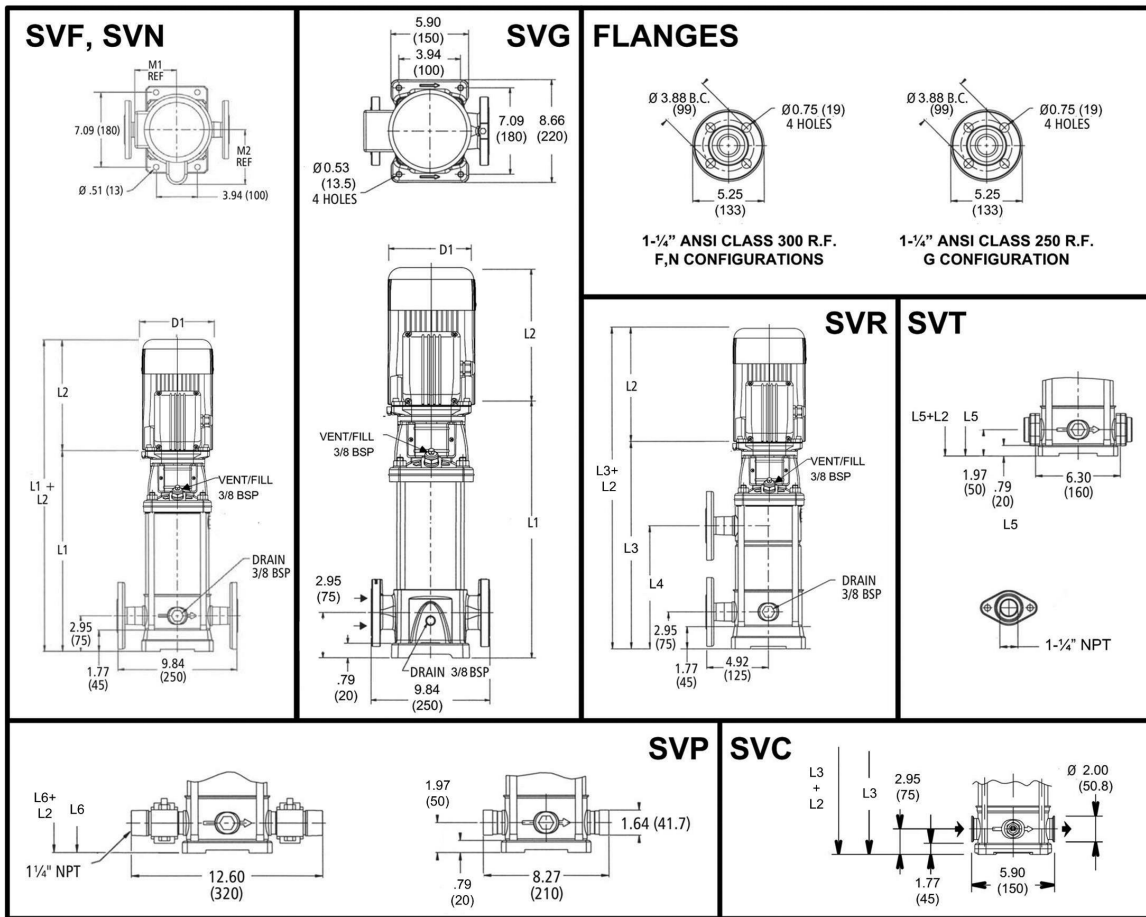

PUMP DIMENSIONS AND WEIGHTS - 1SV SERIES – 50Hz, 2900 RPM ODP/TEFC Enclosures

Pump Type Stages	HP	Motor				Dimensions (in)											Weight (lbs.)												
		NEMA Frame				L1	L2				L3	L4	L5	L6	M (Ref.)	D1 (max.)				D2	Pump Only	Motor				Pump/Motor			
		ODP 1Ø	TEFC 1Ø	ODP 3Ø	TEFC 3Ø		ODP 1Ø	TEFC 1Ø	ODP 3Ø	TEFC 3Ø						ODP 1Ø	TEFC 1Ø	ODP 3Ø	TEFC 3Ø			ODP 1Ø	TEFC 1Ø	ODP 3Ø	TEFC 3Ø	ODP 1Ø	TEFC 1Ø	ODP 3Ø	TEFC 3Ø
1SV-02	0.5	56C	13.27	10.79	9.91	9.16	9.29	-	-	12.29	12.29	5.19	6.19	6.19	6.19	6.19	4.13	25	27	29	21	21	52	54	46	46			
1SV-03			13.27	10.79	9.91	9.16	9.29	-	-	12.29	12.29	5.19	6.19	6.19	6.19	6.19	4.13	26	27	29	21	21	53	55	47	47			
1SV-04			14.06	10.79	9.91	9.16	9.29	-	-	13.07	13.07	5.19	6.19	6.19	6.19	6.19	4.13	27	27	29	21	21	54	56	48	48			
1SV-05			14.85	10.79	9.91	9.16	9.29	-	-	13.86	13.86	5.19	6.19	6.19	6.19	6.19	4.13	28	27	29	21	21	55	57	49	49			
1SV-06			15.63	10.79	9.91	9.16	9.29	-	-	14.65	14.65	5.19	6.19	6.19	6.19	6.19	4.13	28	27	29	21	21	55	57	49	49			
1SV-07			16.42	10.79	9.91	9.16	9.29	-	-	15.44	15.44	5.19	6.19	6.19	6.19	6.19	4.13	29	27	29	21	21	56	58	50	50			
1SV-08			17.21	10.79	9.91	9.16	9.29	17.21	8.94	16.22	16.22	5.19	6.19	6.19	6.19	6.19	4.13	30	27	29	21	21	57	59	51	51			
1SV-09			18.00	10.66	11.19	9.16	9.29	18.00	9.72	17.01	17.01	5.74	6.19	7.19	6.19	6.19	4.13	31	32	40	23	23	63	71	54	54			
1SV-10	18.78	10.66	11.19	9.16	9.29	18.78	10.51	17.80	17.80	5.74	6.19	7.19	6.19	6.19	4.13	32	32	40	23	23	64	72	55	55					
1SV-11	19.57	10.66	11.19	9.16	9.29	19.57	11.30	18.59	18.59	5.74	6.19	7.19	6.19	6.19	4.13	33	32	40	23	23	65	73	56	56					
1SV-12	20.36	10.66	11.19	9.16	9.29	20.36	12.09	19.37	19.37	5.74	6.19	7.19	6.19	6.19	4.13	34	32	40	23	23	66	74	57	57					
1SV-13	21.14	10.67	11.19	10.66	9.91	21.14	12.87	20.16	20.16	5.74	6.19	7.19	6.19	6.19	4.72	35	32	40	30	28	67	75	65	63					
1SV-14	21.93	10.67	11.19	10.66	9.91	21.93	13.66	20.95	20.95	5.74	6.19	7.19	6.19	6.19	4.72	36	32	40	30	28	68	76	66	64					
1SV-15	22.72	10.67	11.19	10.66	9.91	22.72	14.45	21.74	21.74	5.74	6.19	7.19	6.19	6.19	4.72	37	32	40	30	28	69	77	67	65					
1SV-16	23.51	10.67	11.19	10.66	9.91	23.51	15.24	22.52	22.52	5.74	6.19	7.19	6.19	6.19	4.72	38	32	40	30	28	70	78	68	66					
1SV-17	24.29	10.67	11.19	10.66	9.91	24.29	16.02	23.31	23.31	5.74	6.19	7.19	6.19	6.19	4.72	38	32	40	30	28	70	78	68	66					
1SV-18	25.08	11.18	12.06	11.16	10.79	25.08	16.81	24.10	24.10	5.74	7.19	7.19	6.19	6.19	4.72	39	43	51	32	33	82	90	71	72					
1SV-19	25.87	11.18	12.06	11.16	10.79	25.87	17.60	24.89	24.89	5.74	7.19	7.19	6.19	6.19	4.72	40	43	51	32	33	83	91	72	73					
1SV-20	26.66	11.18	12.06	11.16	10.79	26.66	18.39	25.67	25.67	5.74	7.19	7.19	6.19	6.19	4.72	41	43	51	32	33	84	92	73	74					
1SV-21	27.44	11.18	12.06	11.16	10.79	27.44	19.17	26.46	26.46	5.74	7.19	7.19	6.19	6.19	4.72	42	43	51	32	33	85	93	74	75					
1SV-22	28.23	11.18	12.06	11.16	10.79	28.23	19.96	27.25	27.25	5.74	7.19	7.19	6.19	6.19	4.72	43	43	51	32	33	86	94	75	76					
1SV-23	29.02	11.18	12.06	11.16	10.79	29.02	20.75	28.03	28.03	5.74	7.19	7.19	6.19	6.19	4.72	45	43	51	32	33	88	96	77	78					
1SV-24	29.81	11.18	12.06	11.16	10.79	29.81	21.54	28.82	28.82	5.74	7.19	7.19	6.19	6.19	4.72	46	43	51	32	33	89	97	78	79					
1SV-25	30.59	11.18	12.06	11.16	10.79	30.59	22.32	29.61	29.61	5.74	7.19	7.19	6.19	6.19	4.72	47	43	51	32	33	90	98	79	80					
1SV-26	31.38	11.57	13.44	11.18	11.16	31.38	23.11	30.40	30.40	5.75	6.50	7.19	7.16	7.19	5.51	47	49	64	41	44	96	111	88	91					
1SV-27	32.17	11.57	13.44	11.18	11.16	32.17	23.90	-	31.18	5.75	6.50	7.19	7.16	7.19	5.51	48	49	64	41	44	97	112	89	92					
1SV-28	32.96	11.57	13.44	11.18	11.16	32.96	24.68	-	31.97	5.75	6.50	7.19	7.16	7.19	5.51	49	49	64	41	44	98	113	90	93					
1SV-29	34.14	11.57	13.44	11.18	11.16	34.14	25.47	-	33.15	5.75	6.50	7.19	7.16	7.19	5.51	50	49	64	41	44	99	114	91	94					
1SV-30	34.53	11.57	13.44	11.18	11.16	34.53	26.26	-	33.55	5.75	6.50	7.19	7.16	7.19	5.51	51	49	64	41	44	100	115	92	95					

Performance Curve

1SV 50 Hz 2900 RPM

LOW NPSH CURVE

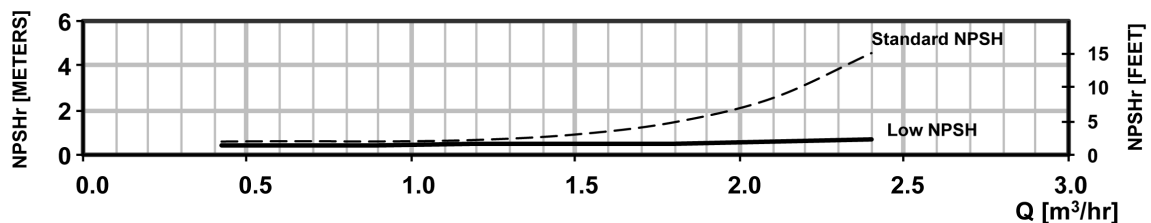
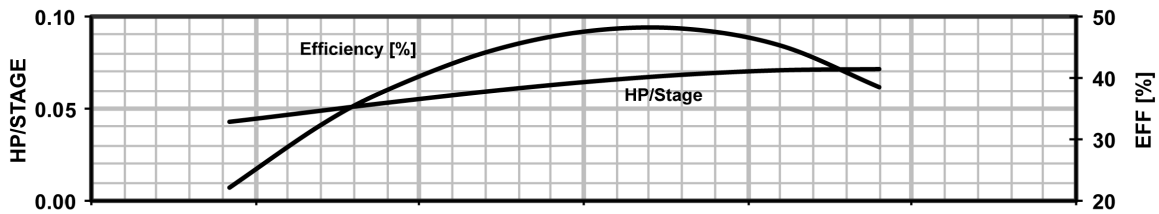
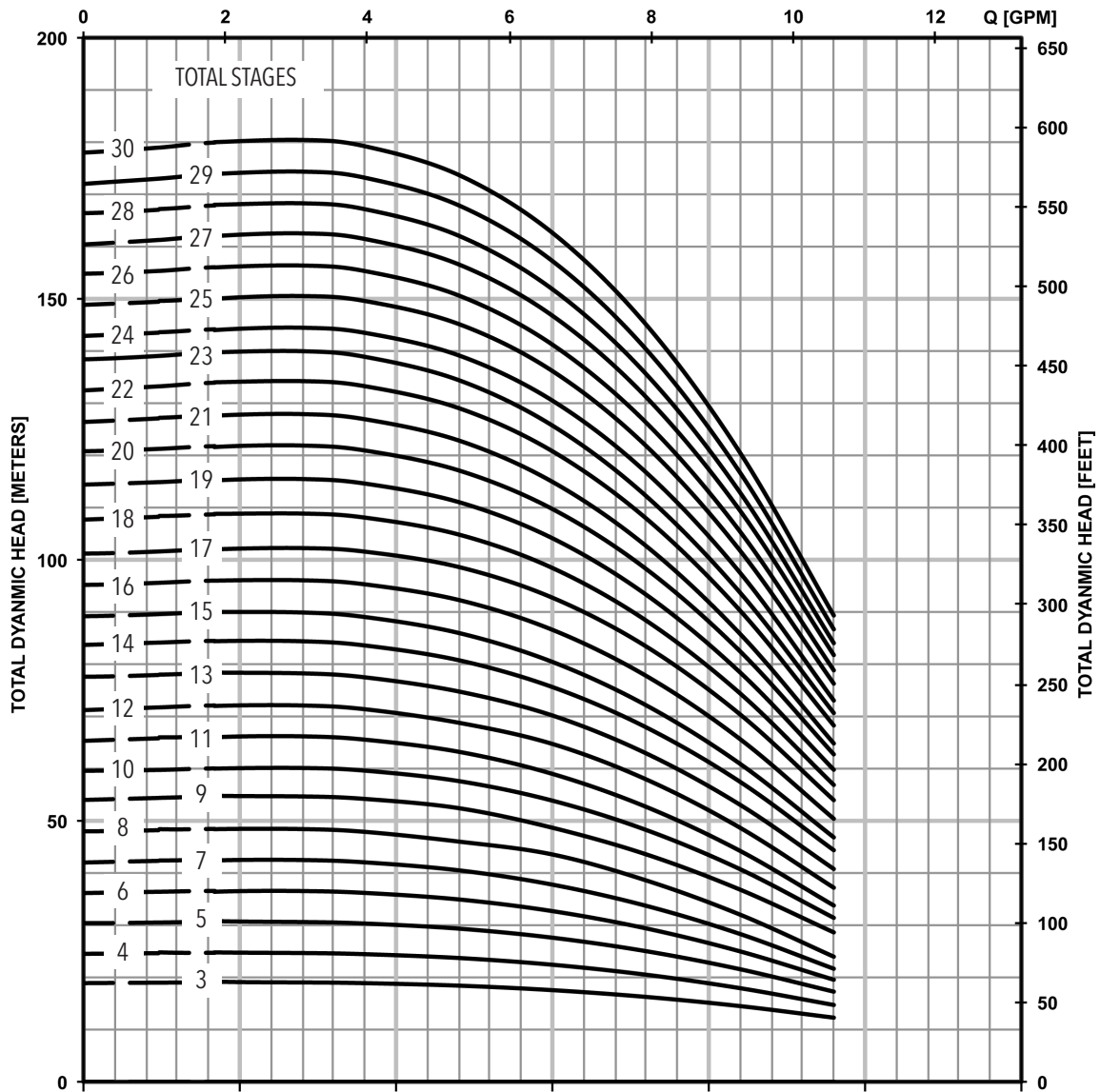

MINIMUM FLOW RATE: .5 m³/hr [2 GPM]

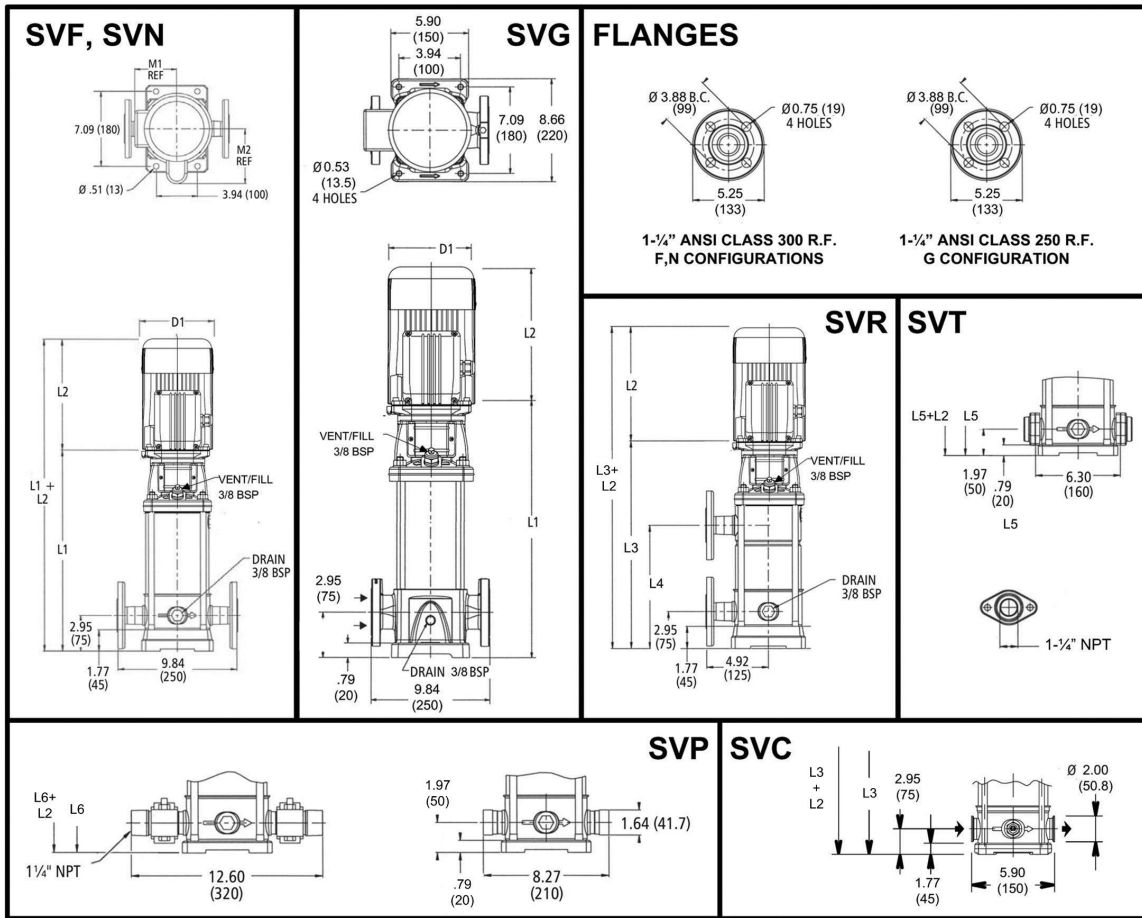

PUMP DIMENSIONS AND WEIGHTS - 3SV SERIES – 50Hz, 2900 RPM ODP/TEFC Enclosures

Pump Type Stages	Motor				Dimensions (in)											Weight (lbs.)														
	HP	NEMA Frame			L1	L2				L3	L4	L5	L6	M (Ref.)	D1 (max.)				D2	Pump	Motor				Pump/Motor					
		ODP 1Ø	TEFC 1Ø	ODP 3Ø		TEFC 3Ø	ODP 1Ø	TEFC 1Ø	ODP 3Ø						TEFC 3Ø	ODP 1Ø	TEFC 1Ø	ODP 3Ø			TEFC 3Ø	ODP 1Ø	TEFC 1Ø	ODP 3Ø	TEFC 3Ø	ODP 1Ø	TEFC 1Ø	ODP 3Ø	TEFC 3Ø	
3SV-02	0.5	56C			13.27	10.79	9.91	9.16	9.29	-	-	12.29	12.29	5.19	6.19	6.19	6.19	6.19	4.13	24	27	29	21	21	51	53	45	45		
3SV-03					13.27	10.79	9.91	9.16	9.29	-	-	12.29	12.29	5.19	6.19	6.19	6.19	6.19	6.19	6.19	4.13	25	27	29	21	21	52	54	46	46
3SV-04					14.06	10.79	9.91	9.16	9.29	-	-	13.07	13.07	5.19	6.19	6.19	6.19	6.19	6.19	6.19	4.13	26	27	29	21	21	53	55	47	47
3SV-05					14.85	10.79	9.91	9.16	9.29	-	-	13.86	13.86	5.19	6.19	6.19	6.19	6.19	6.19	6.19	4.13	27	27	29	21	21	54	56	48	48
3SV-06					15.63	10.66	11.19	9.16	9.29	-	-	14.65	14.65	5.74	6.19	7.19	6.19	6.19	6.19	6.19	4.13	28	32	40	23	23	60	68	51	51
3SV-07					16.42	10.66	11.19	9.16	9.29	-	-	15.44	15.44	5.74	6.19	7.19	6.19	6.19	6.19	6.19	4.13	30	32	40	23	23	62	70	53	53
3SV-08					17.21	10.67	11.19	10.66	9.91	17.21	8.94	16.22	16.22	5.74	6.19	7.19	6.19	6.19	6.19	6.19	4.72	31	32	40	30	28	63	71	61	59
3SV-09					18.00	10.67	11.19	10.66	9.91	18.00	9.72	17.01	17.01	5.74	6.19	7.19	6.19	6.19	6.19	6.19	4.72	32	32	40	30	28	64	72	62	60
3SV-10					18.78	10.67	11.19	10.66	9.91	18.78	10.51	17.80	17.80	5.74	6.19	7.19	6.19	6.19	6.19	6.19	4.72	33	32	40	30	28	65	73	63	61
3SV-11					19.57	11.18	12.06	11.16	10.79	19.57	11.30	18.59	18.59	5.74	7.19	7.19	6.19	6.19	6.19	6.19	4.72	34	43	51	32	33	77	85	66	67
3SV-12					20.36	11.18	12.06	11.16	10.79	20.36	12.09	19.37	19.37	5.74	7.19	7.19	6.19	6.19	6.19	6.19	4.72	35	43	51	32	33	78	86	67	68
3SV-13					21.14	11.18	12.06	11.16	10.79	21.14	12.87	20.16	20.16	5.74	7.19	7.19	6.19	6.19	6.19	6.19	4.72	36	43	51	32	33	79	87	68	69
3SV-14					21.93	11.18	12.06	11.16	10.79	21.93	13.66	20.95	20.95	5.74	7.19	7.19	6.19	6.19	6.19	6.19	4.72	37	43	51	32	33	80	88	69	70
3SV-15					22.72	11.18	12.06	11.16	10.79	22.72	14.45	21.74	21.74	5.74	7.19	7.19	6.19	6.19	6.19	6.19	4.72	38	43	51	32	33	81	89	70	71
3SV-16					23.51	11.57	13.44	11.18	11.16	23.51	15.24	22.52	22.52	5.75	6.50	7.19	7.16	7.19	5.51	5.51	39	49	64	41	44	88	103	80	83	
3SV-17	24.29	11.57	13.44	11.18	11.16	24.29	16.02	23.31	23.31	5.75	6.50	7.19	7.16	7.19	5.51	5.51	40	49	64	41	44	89	104	81	84					
3SV-18	25.08	11.57	13.44	11.18	11.16	25.08	16.81	24.10	24.10	5.75	6.50	7.19	7.16	7.19	5.51	5.51	41	49	64	41	44	90	105	82	85					
3SV-19	25.87	11.57	13.44	11.18	11.16	25.87	17.60	24.89	24.89	5.75	6.50	7.19	7.16	7.19	5.51	5.51	41	49	64	41	44	90	105	82	85					
3SV-20	26.66	11.57	13.44	11.18	11.16	26.66	18.39	25.67	25.67	5.75	6.50	7.19	7.16	7.19	5.51	5.51	42	49	64	41	44	91	106	83	86					
3SV-21	27.44	11.57	13.44	11.18	11.16	27.44	19.17	26.46	26.46	5.75	6.50	7.19	7.16	7.19	5.51	5.51	43	49	64	41	44	92	107	84	87					
3SV-22	28.93	13.93	15.43	12.55	13.93	28.93	19.96	-	27.95	6.87	8.88	8.86	9.02	8.86	5.51	5.51	46	81	92	62	69	127	138	108	115					
3SV-23	29.72	13.93	15.43	12.55	13.93	29.72	20.75	-	28.73	6.87	8.88	8.86	9.02	8.86	5.51	5.51	47	81	92	62	69	128	139	109	116					
3SV-24	30.51	13.93	15.43	12.55	13.93	30.51	21.54	-	29.52	6.87	8.88	8.86	9.02	8.86	5.51	5.51	48	81	92	62	69	129	140	110	117					
3SV-25	31.29	13.93	15.43	12.55	13.93	31.29	22.32	-	30.31	6.87	8.88	8.86	9.02	8.86	5.51	5.51	49	81	92	62	69	130	141	111	118					
3SV-26	32.08	13.93	15.43	12.55	13.93	32.08	23.11	-	31.10	6.87	8.88	8.86	9.02	8.86	5.51	5.51	50	81	92	62	69	131	142	112	119					
3SV-27	32.47	13.93	15.43	12.55	13.93	32.47	23.90	-	31.49	6.87	8.88	8.86	9.02	8.86	5.51	5.51	52	81	92	62	69	133	144	114	121					
3SV-28	33.26	13.93	15.43	12.55	13.93	33.26	24.68	-	32.28	6.87	8.88	8.86	9.02	8.86	5.51	5.51	53	81	92	62	69	134	145	115	122					
3SV-29	34.44	13.93	15.43	12.55	13.93	34.44	25.47	-	33.46	6.87	8.88	8.86	9.02	8.86	5.51	5.51	54	81	92	62	69	135	146	116	123					
3SV-30	35.23	13.93	15.43	12.55	13.93	35.23	26.26	-	34.25	6.87	8.88	8.86	9.02	8.86	5.51	5.51	55	81	92	62	69	136	147	117	124					

Performance Curve

3SV 50 Hz 2900 RPM

LOW NPSH CURVE

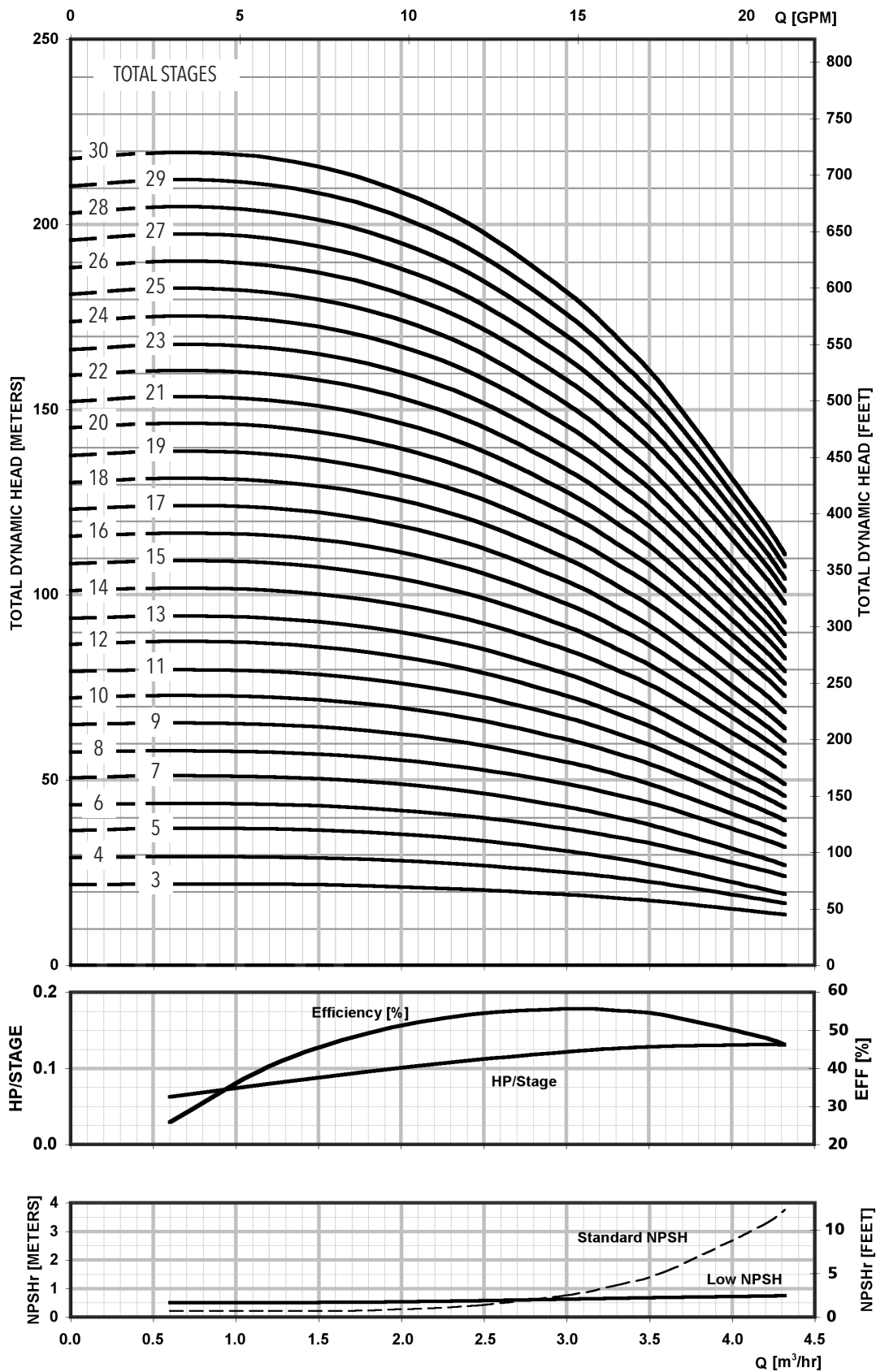

MINIMUM FLOW RATE: .7 m³/hr [3 GPM]

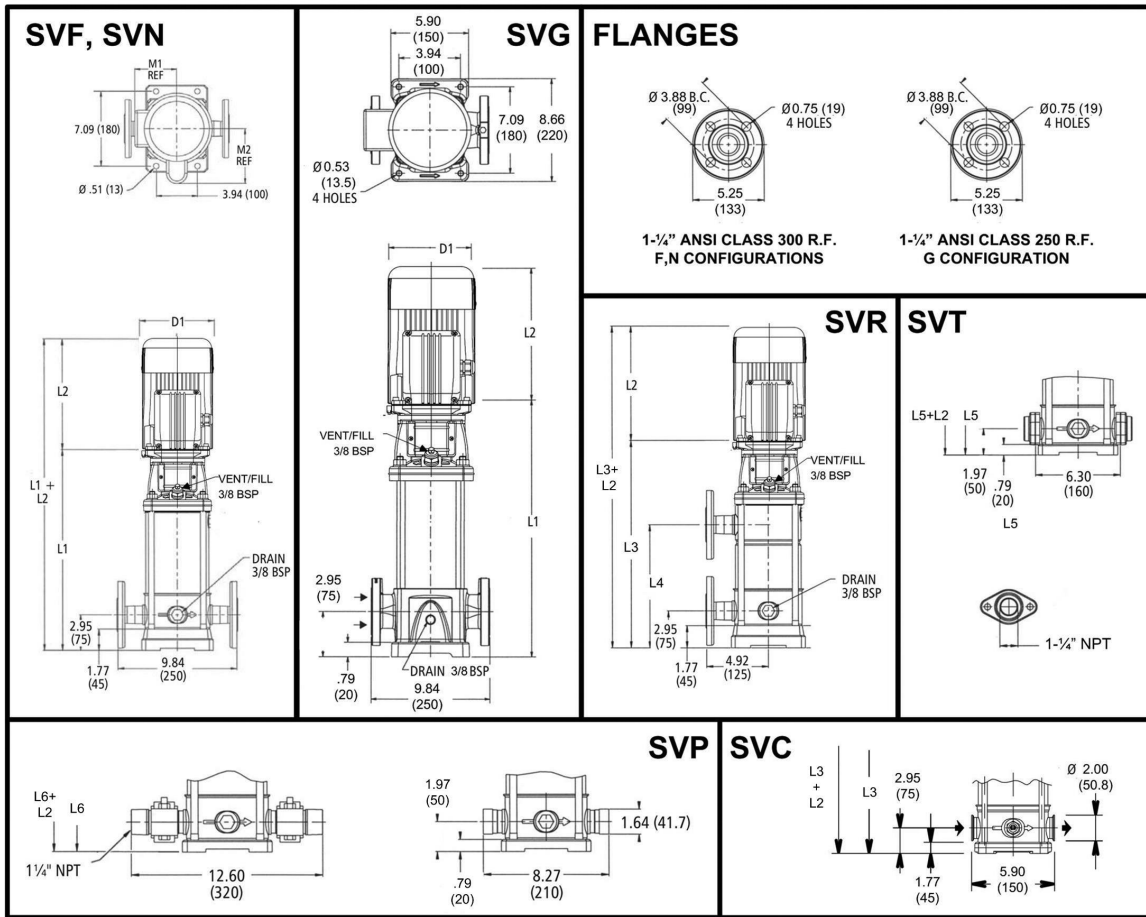

All dimensions are in inches (mm).

PUMP DIMENSIONS AND WEIGHTS - 5SV SERIES – 50Hz, 2900 RPM ODP/TEFC Enclosures

Pump Type Stages	Motor					Dimensions (in)											Weight (lbs.)												
	HP	NEMA Frame				L1	L2				L3	L4	L5	L6	M (Ref.)	D1 (max.)				D2	Pump	Motor				Pump/Motor			
		ODP 1Ø	TEFC 1Ø	ODP 3Ø	TEFC 3Ø		ODP 1Ø	TEFC 1Ø	ODP 3Ø	TEFC 3Ø						ODP 1Ø	TEFC 1Ø	ODP 3Ø	TEFC 3Ø			ODP 1Ø	TEFC 1Ø	ODP 3Ø	TEFC 3Ø	ODP 1Ø	TEFC 1Ø	ODP 3Ø	TEFC 3Ø
5SV-02	0.75	56C			13.86	10.66	11.19	9.16	9.29	-	-	12.88	12.88	5.74	6.19	7.19	6.19	6.19	4.13	25	32	40	23	23	57	65	48	48	
5SV-03					13.86	10.66	11.19	9.16	9.29	-	-	12.88	12.88	5.74	6.19	7.19	6.19	6.19	4.13	26	32	40	23	23	58	66	49	49	
5SV-04					14.85	10.67	11.19	10.66	9.91	-	-	13.86	13.86	5.74	6.19	7.19	6.19	6.19	4.72	28	32	40	30	28	60	68	58	56	
5SV-05	1.5	56C			15.83	11.18	12.06	11.16	10.79	-	-	14.85	14.85	5.74	7.19	7.19	6.19	6.19	4.72	29	43	51	32	33	72	80	61	62	
5SV-06					16.81	11.18	12.06	11.16	10.79	-	-	15.83	15.83	5.74	7.19	7.19	6.19	6.19	4.72	30	43	51	32	33	73	81	62	63	
5SV-07					17.80	11.18	12.06	11.16	10.79	17.80	9.53	16.81	16.81	5.74	7.19	7.19	6.19	6.19	4.72	31	43	51	32	33	74	82	63	64	
5SV-08	2	56C			18.78	11.18	12.06	11.16	10.79	18.78	10.51	17.80	17.80	5.74	7.19	7.19	6.19	6.19	4.72	33	43	51	32	33	76	84	65	66	
5SV-09					19.77	11.57	13.44	11.18	11.16	19.77	11.50	18.78	18.78	5.75	6.50	7.19	7.16	7.19	5.51	33	49	64	41	44	82	97	74	77	
5SV-10					20.75	11.57	13.44	11.18	11.16	20.75	12.48	19.77	19.77	5.75	6.50	7.19	7.16	7.19	5.51	34	49	64	41	44	83	98	75	78	
5SV-11	3	184TC	182TC	184TC	21.74	11.57	13.44	11.18	11.16	21.74	13.46	20.75	20.75	5.75	6.50	7.19	7.16	7.19	5.51	35	49	64	41	44	84	99	76	79	
5SV-12					23.42	13.93	15.43	12.55	13.93	23.42	14.45	22.44	22.44	6.87	8.88	8.86	9.02	8.86	5.51	38	81	92	62	69	119	130	100	107	
5SV-13					24.40	13.93	15.43	12.55	13.93	24.40	15.43	23.42	23.42	6.87	8.88	8.86	9.02	8.86	5.51	40	81	92	62	69	121	132	102	109	
5SV-14	5	213TC	184TC		25.39	13.93	15.43	12.55	13.93	25.39	16.42	24.40	24.40	6.87	8.88	8.86	9.02	8.86	5.51	40	81	92	62	69	121	132	102	109	
5SV-15					26.37	13.93	15.43	12.55	13.93	26.37	17.40	25.39	25.39	6.87	8.88	8.86	9.02	8.86	5.51	41	81	92	62	69	122	133	103	110	
5SV-16					27.36	13.93	15.43	12.55	13.93	27.36	18.39	26.37	26.37	6.87	8.88	8.86	9.02	8.86	5.51	43	81	92	62	69	124	135	105	112	
5SV-17	5	213TC	184TC		28.54	13.93	15.43	12.55	13.93	28.54	19.37	27.55	27.55	6.87	8.88	8.86	9.02	8.86	5.51	45	81	92	62	69	126	137	107	114	
5SV-18					29.33	13.88	15.53	13.93	15.43	29.33	20.35	28.34	28.34	8.05	8.89	10.62	8.88	8.86	5.51	46	100	120	75	85	146	166	121	131	
5SV-19					30.51	13.88	15.53	13.93	15.43	30.51	21.34	29.52	29.52	8.05	8.89	10.62	8.88	8.86	5.51	47	100	120	75	85	147	167	122	132	
5SV-20	5	213TC	184TC		31.69	13.88	15.53	13.93	15.43	31.69	22.32	30.70	30.70	8.05	8.89	10.62	8.88	8.86	5.51	48	100	120	75	85	148	168	123	133	
5SV-21					32.28	13.88	15.53	13.93	15.43	32.28	23.31	31.29	31.29	8.05	8.89	10.62	8.88	8.86	5.51	49	100	120	75	85	149	169	124	134	
5SV-22					33.34	13.88	15.53	13.93	15.43	33.34	24.29	-	32.36	8.05	8.89	10.62	8.88	8.86	5.51	50	100	120	75	85	150	170	125	135	
5SV-23	5	213TC	184TC		34.25	13.88	15.53	13.93	15.43	34.25	25.28	-	33.26	8.05	8.89	10.62	8.88	8.86	5.51	51	100	120	75	85	151	171	126	136	
5SV-24					35.31	13.88	15.53	13.93	15.43	35.31	26.26	-	34.33	8.05	8.89	10.62	8.88	8.86	5.51	53	100	120	75	85	153	173	128	138	
5SV-25					36.21	13.88	15.53	13.93	15.43	36.21	27.24	-	35.23	8.05	8.89	10.62	8.88	8.86	5.51	53	100	120	75	85	153	173	128	138	
5SV-26	5	213TC	184TC		37.28	13.88	15.53	13.93	15.43	37.28	28.23	-	36.29	8.05	8.89	10.62	8.88	8.86	5.51	54	100	120	75	85	154	174	129	139	
5SV-27					38.26	13.88	15.53	13.93	15.43	38.26	29.21	-	37.28	8.05	8.89	10.62	8.88	8.86	5.51	55	100	120	75	85	155	175	130	140	

Performance Curve

5SV 50 Hz 2900 RPM

LOW NPSH CURVE

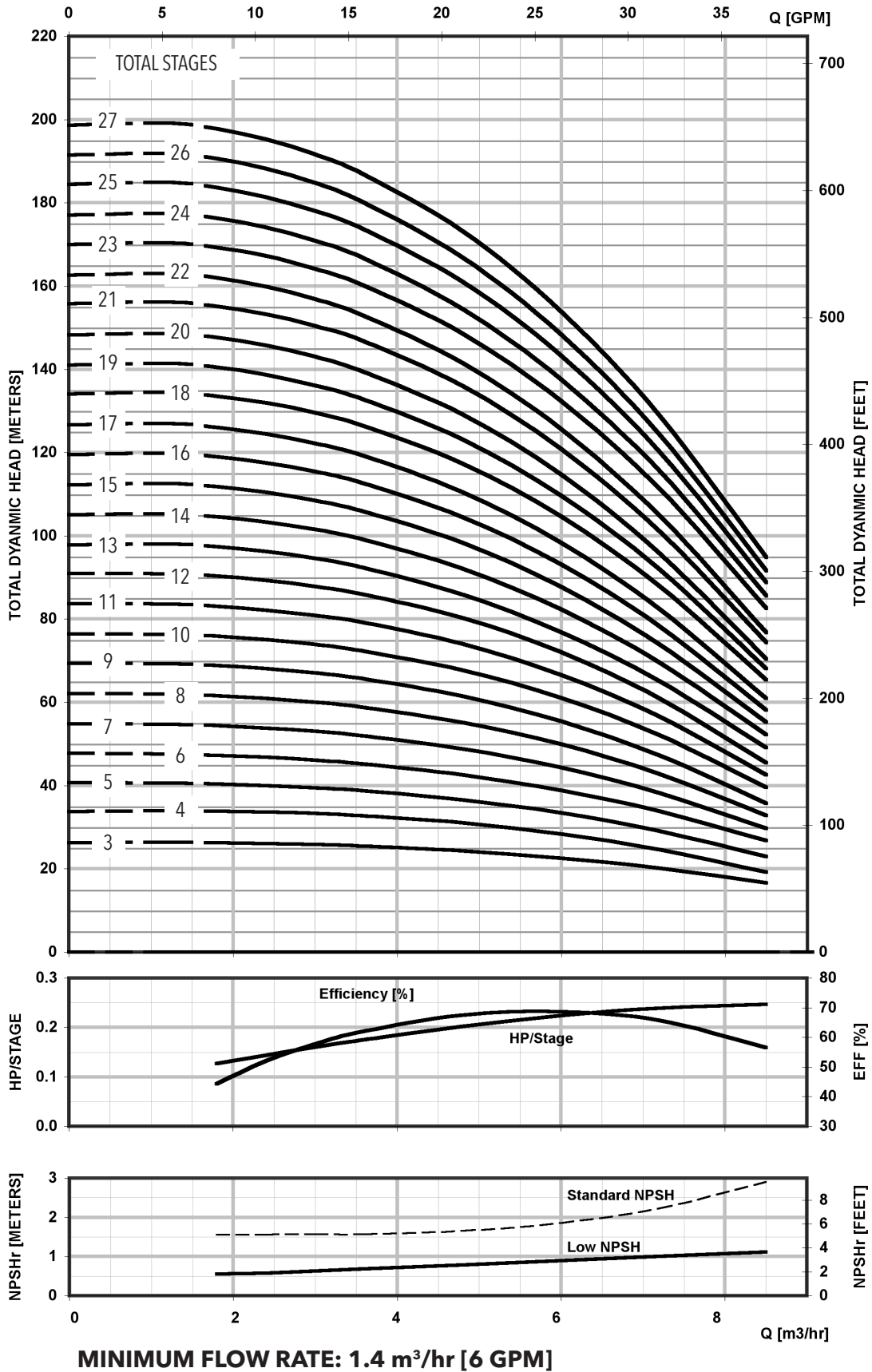

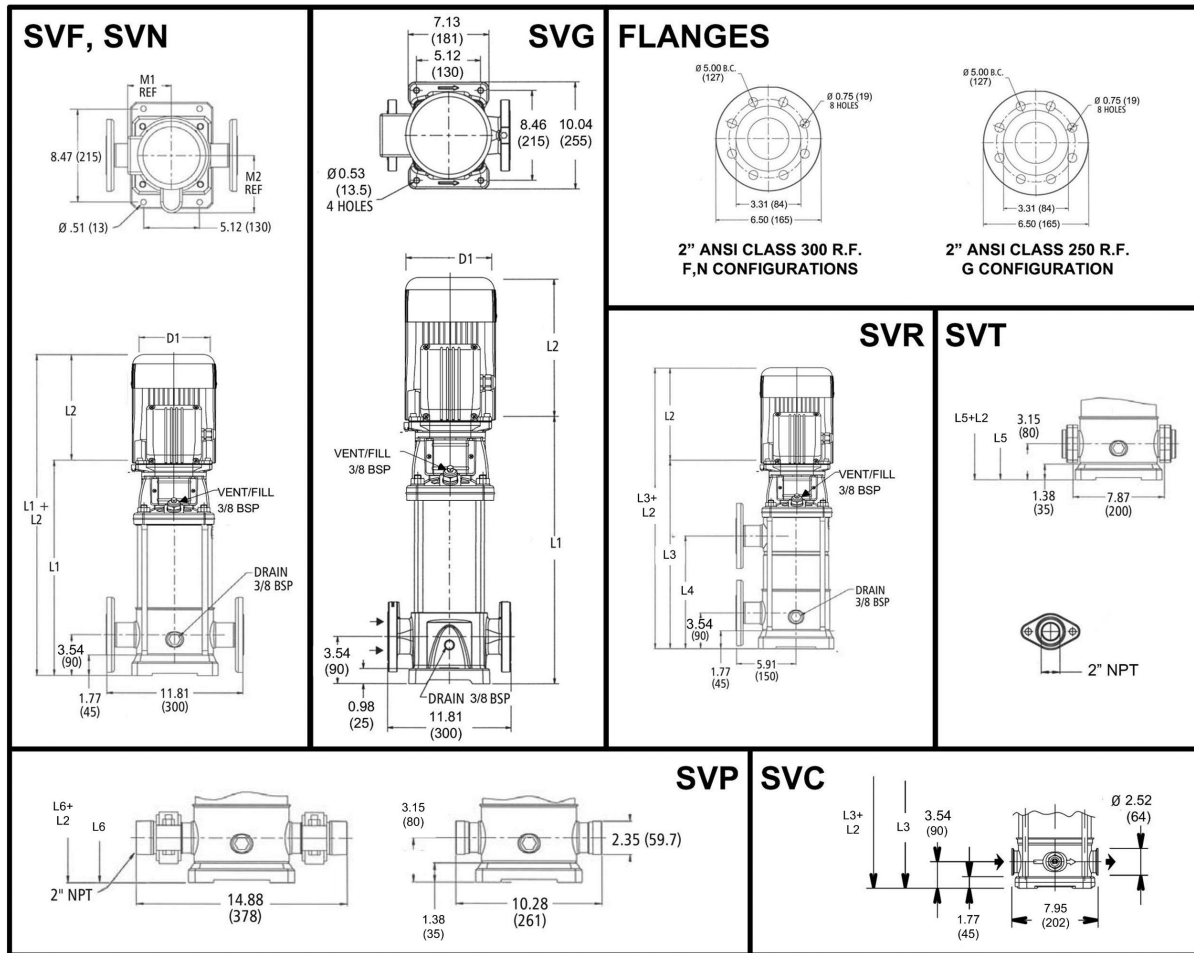

PUMP DIMENSIONS AND WEIGHTS - 10SV SERIES – 50Hz, 2900 RPM ODP/TEFC Enclosures

Pump Type Stages	Motor					Dimensions (in)											Weight (lbs.)												
	HP	NEMA Frame				L1	L2				L3	L4	L5	L6	M (Ref.)	D1 (max.)				D2	Pump	Motor				Pump/Motor			
		ODP 1Ø	TEFC 1Ø	ODP 3Ø	TEFC 3Ø		ODP 1Ø	TEFC 1Ø	ODP 3Ø	TEFC 3Ø						ODP 1Ø	TEFC 1Ø	ODP 3Ø	TEFC 3Ø			ODP 1Ø	TEFC 1Ø	ODP 3Ø	TEFC 3Ø	ODP 1Ø	TEFC 1Ø	ODP 3Ø	TEFC 3Ø
10SV-02	1.5	56C				16.56	11.18	12.06	11.16	10.79	-	-	16.17	16.17	5.74	7.19	7.19	6.19	6.19	4.72	38	43	51	32	33	81	89	70	71
10SV-03						17.82	11.18	12.06	11.16	10.79	-	-	17.43	17.43	5.74	7.19	7.19	6.19	6.19	4.72	40	43	51	32	33	83	91	72	73
10SV-04						2	19.08	11.57	13.44	11.18	11.16	-	-	18.69	18.69	5.75	6.50	7.19	7.16	7.19	5.51	43	49	64	41	44	92	107	84
10SV-05	3	184TC	182TC	184TC	20.84	13.93	15.43	12.55	13.93	20.84	10.20	20.45	20.45	6.87	8.88	8.86	9.02	8.86	5.51	48	81	92	62	69	129	140	110	117	
10SV-06					22.10	13.93	15.43	12.55	13.93	22.10	11.46	21.71	21.71	6.87	8.88	8.86	9.02	8.86	5.51	50	81	92	62	69	131	142	112	119	
10SV-07					23.36	13.93	15.43	12.55	13.93	23.36	12.72	22.97	22.97	6.87	8.88	8.86	9.02	8.86	5.51	52	81	92	62	69	133	144	114	121	
10SV-08	5	213TC	184TC	184TC	24.62	13.88	15.53	13.93	15.43	24.62	13.98	24.22	24.22	8.05	8.89	10.62	8.88	8.86	5.51	54	100	120	75	85	154	174	129	139	
10SV-09					25.88	13.88	15.53	13.93	15.43	25.88	15.24	25.48	25.48	8.05	8.89	10.62	8.88	8.86	5.51	56	100	120	75	85	156	176	131	141	
10SV-10					27.14	13.88	15.53	13.93	15.43	27.14	16.50	26.74	26.74	8.05	8.89	10.62	8.88	8.86	5.51	59	100	120	75	85	159	179	134	144	
10SV-11	7.5	215TC	213TC	215TC	28.40	13.88	15.53	13.93	15.43	28.40	17.76	28.00	28.00	8.05	8.89	10.62	8.88	8.86	5.51	61	100	120	75	85	161	181	136	146	
10SV-12					29.44	16.63	16.68	15.55	15.51	29.44	19.02	29.05	29.05	8.77	10.62	10.18	10.18	10.28	5.51	70	132	145	107	122	202	215	177	192	
10SV-13					31.51	16.63	16.68	15.55	15.51	31.51	20.28	31.11	31.11	8.77	10.62	10.18	10.18	10.28	5.51	75	132	145	107	122	207	220	182	197	
10SV-14	10	-	215TC	254TC	32.85	16.63	16.68	15.55	15.51	32.85	21.54	-	32.45	8.77	10.62	10.18	10.18	10.28	5.51	77	132	145	107	122	209	222	184	199	
10SV-15					34.03	16.63	16.68	15.55	15.51	34.03	22.80	-	33.63	8.77	10.62	10.18	10.18	10.28	5.51	79	132	145	107	122	211	224	186	201	
10SV-16					35.29	16.63	16.68	15.55	15.51	35.29	24.06	-	34.89	8.77	10.62	10.18	10.18	10.28	5.51	81	132	145	107	122	213	226	188	203	
10SV-17	10	-	215TC	254TC	36.55	16.63	16.68	15.55	15.51	36.55	25.31	-	36.15	8.77	10.62	10.18	10.18	10.28	5.51	83	132	145	107	122	215	228	190	205	
10SV-18					38.44	-	-	15.55	16.57	38.44	26.57	-	38.04	9.22	-	-	10.18	10.28	5.51	90	-	-	125	195	-	-	215	285	
10SV-19					39.78	-	-	15.55	16.57	39.78	27.83	-	39.38	9.22	-	-	10.18	10.28	5.51	92	-	-	125	195	-	-	217	287	
10SV-20	10	-	215TC	254TC	40.96	-	-	15.55	16.57	40.96	29.09	-	40.56	9.22	-	-	10.18	10.28	5.51	94	-	-	125	195	-	-	219	289	

Performance Curve

10SV 50 Hz 2900 RPM

LOW NPSH CURVE

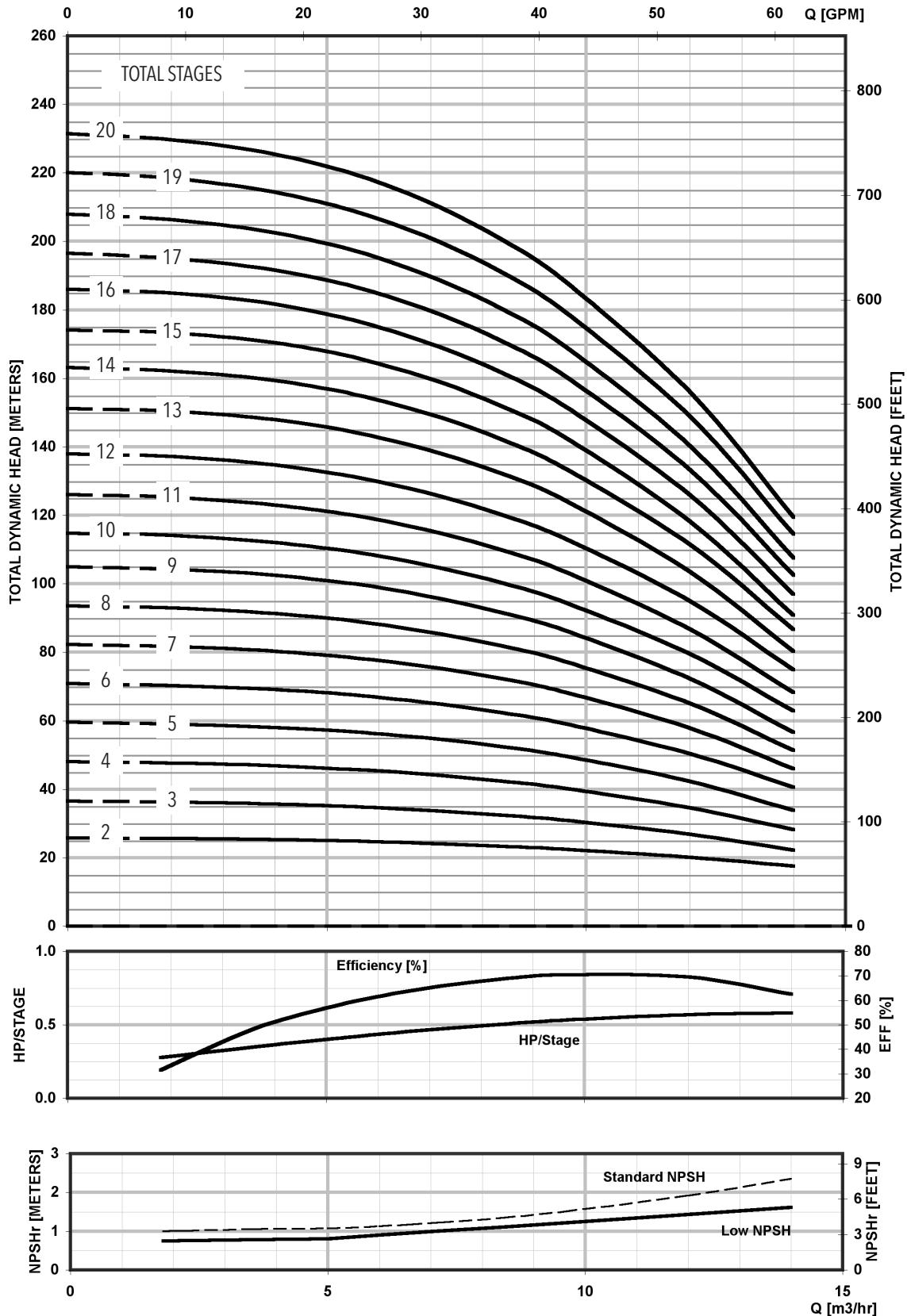

MINIMUM FLOW RATE: 1.8 m³/hr [8 GPM]

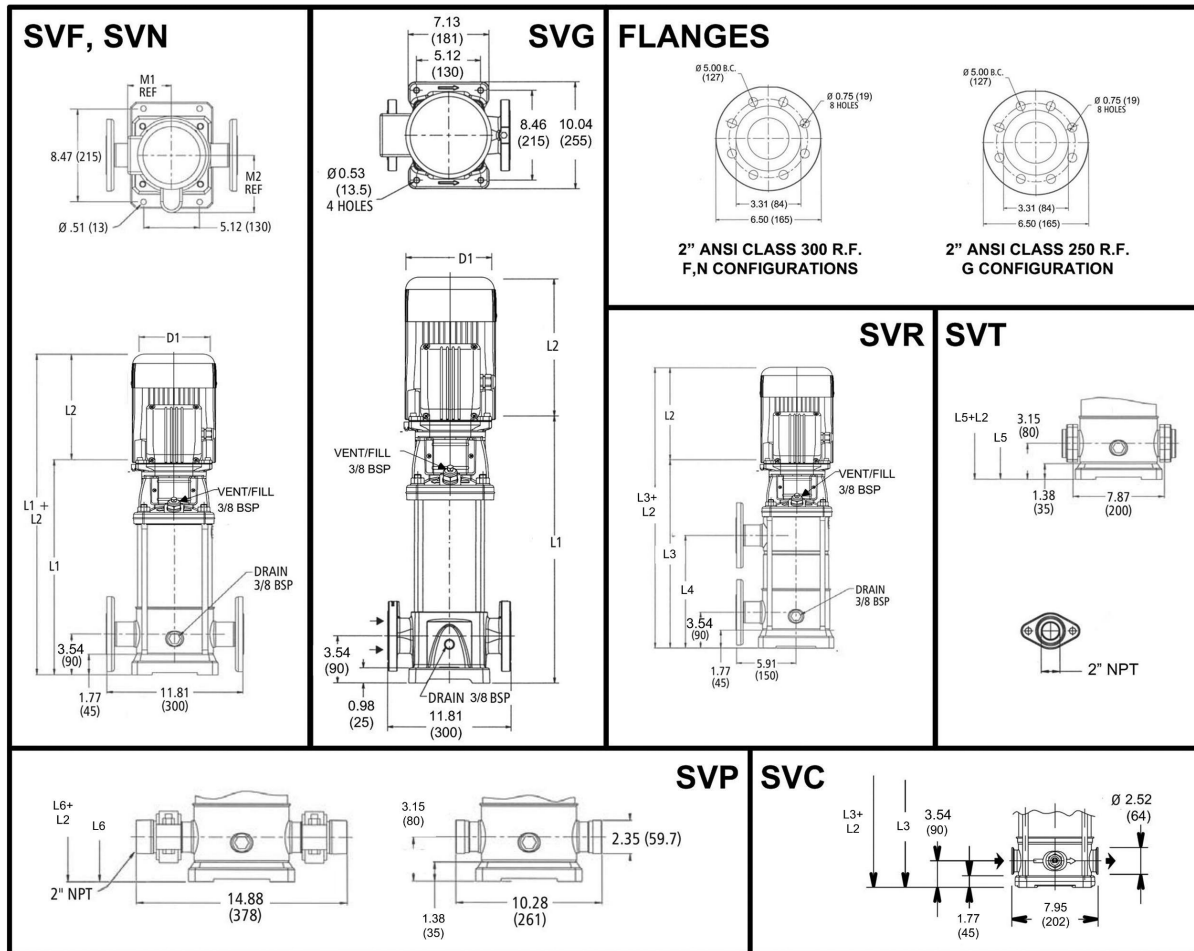

All dimensions are in inches (mm).

PUMP DIMENSIONS AND WEIGHTS - 15SV SERIES – 50Hz, 2900 RPM ODP/TEFC Enclosures

Pump Type Stages	HP	Motor			Dimensions (in)												Weight (lbs.)															
		NEMA Frame			L1	L2				L3	L4	L5	L6	M (Ref.)	D1 (max.)				D2	Pump	Motor						Pump/Motor					
		ODP 10	TEFC 10	ODP 30		TEFC 30	ODP 10	TEFC 10	ODP 30						TEFC 30	ODP 10	TEFC 10	ODP 30			TEFC 30	ODP 10	TEFC 10	ODP 30	TEFC 30	ODPE 30	TEPE 30	ODP 10	TEFC 10	ODP 30	TEFC 30	ODPE 30
15SV02	3	184TC	182TC	184TC	18.71	13.93	15.43	12.55	13.93	-	-	18.32	18.32	6.87	8.88	8.86	9.02	8.86	5.51	44	81	92	62	69	75	73	125	136	106	113	119	117
15SV03	5	213TC	184TC	184TC	20.60	13.88	15.53	13.93	15.43	-	-	20.21	20.21	8.05	8.89	10.62	8.88	8.86	5.51	47	100	120	75	85	69	80	147	167	122	132	116	127
15SV04					22.49	13.88	15.53	13.93	15.43	22.49	11.85	22.10	22.10	8.05	8.89	10.62	8.88	8.86	5.51	50	100	120	75	85	69	80	150	170	125	135	119	130
15SV05	7.5	215TC	213TC	215TC	24.95	16.63	16.68	15.55	15.51	24.95	13.74	24.56	24.56	8.77	10.62	10.18	10.18	10.28	5.51	59	132	145	107	122	103	118	191	204	166	181	162	177
15SV06					26.86	16.63	16.68	15.55	15.51	26.86	15.63	26.47	26.47	8.77	10.62	10.18	10.18	10.28	5.51	66	132	145	107	122	103	118	198	211	173	188	169	184
15SV07					28.75	16.63	16.68	15.55	15.51	28.75	17.52	28.36	28.36	8.77	10.62	10.18	10.28	5.51	69	132	145	107	122	103	118	201	214	176	191	172	187	
15SV08	10	215TC	254TC	31.27	-	-	15.55	16.57	31.27	19.41	30.88	30.88	9.22	-	-	10.18	10.28	5.51	76	-	-	125	195	130	154	-	-	201	271	206	230	
15SV09				33.16	-	-	15.55	16.57	33.16	21.30	32.77	32.77	9.22	-	-	10.18	10.28	5.51	79	-	-	125	195	130	154	-	-	204	274	209	233	
15SV10				35.05	-	-	15.55	16.57	35.05	23.19	34.66	34.66	9.22	-	-	10.18	10.28	5.51	83	-	-	125	195	130	154	-	-	208	278	213	237	
15SV11				36.94	-	-	16.66	20.08	36.94	25.08	-	36.55	9.5	-	-	10.18	13.13	5.51	86	-	-	144	285	128	276	-	-	230	371	214	362	
15SV12				38.83	-	-	16.66	20.08	38.83	26.97	-	38.44	9.5	-	-	10.18	13.13	5.51	89	-	-	144	285	128	276	-	-	233	374	217	365	
15SV13	15	254TC	256TC	40.72	-	-	16.66	20.08	40.72	28.86	-	40.33	9.5	-	-	10.18	13.13	5.51	92	-	-	144	285	128	276	-	-	236	377	220	368	
15SV14				42.61	-	-	16.66	20.08	42.61	26.97	-	42.22	9.5	-	-	10.18	13.13	5.51	95	-	-	144	285	128	276	-	-	239	380	223	371	
15SV15				44.50	-	-	16.66	20.08	44.50	32.64	-	44.11	9.5	-	-	10.18	13.13	5.51	98	-	-	144	285	128	276	-	-	242	383	226	374	

Performance Curve

15SV 50 Hz 2900 RPM

LOW NPSH CURVE

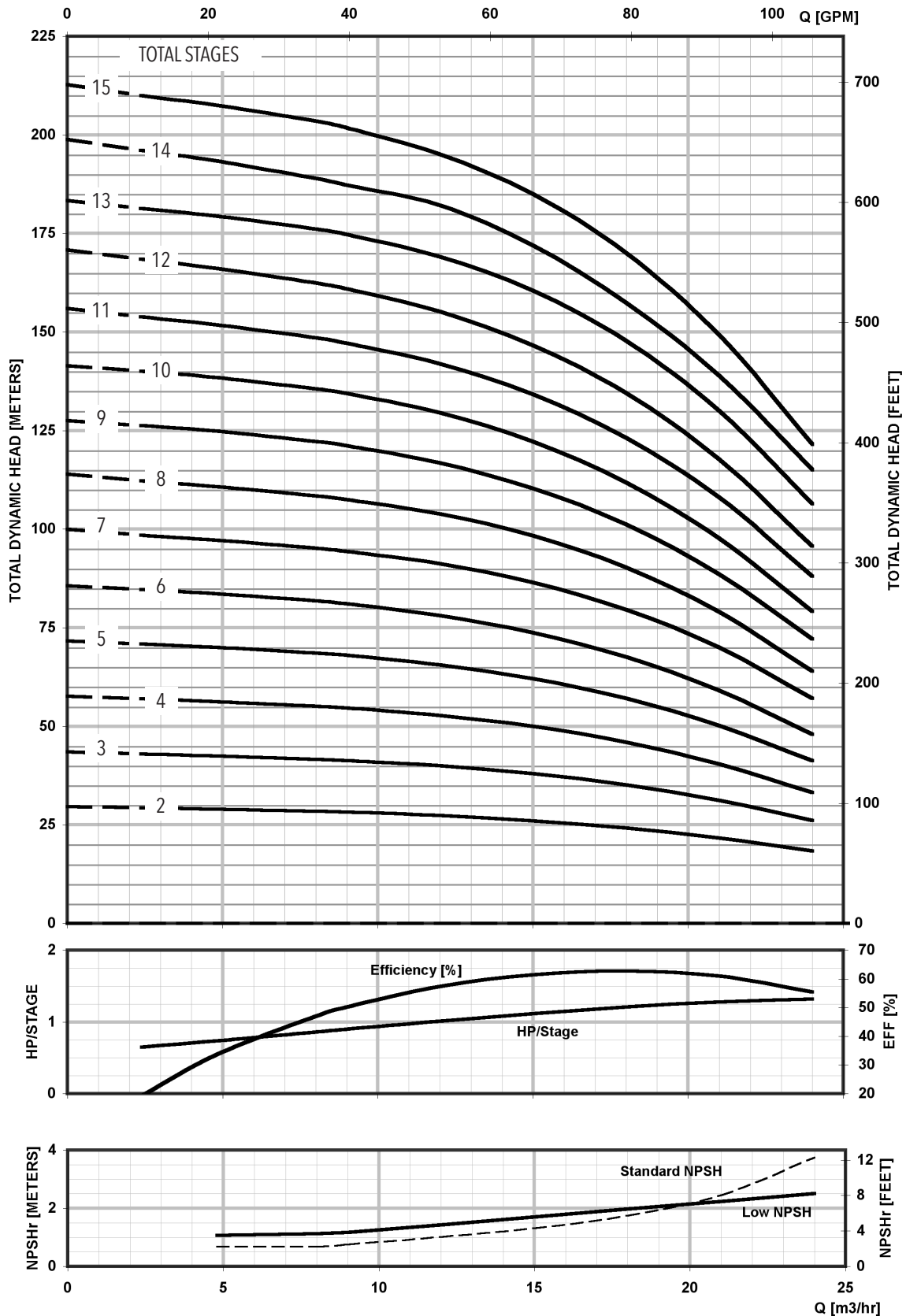

MINIMUM FLOW RATE: 3.4 m³/hr [15 GPM]

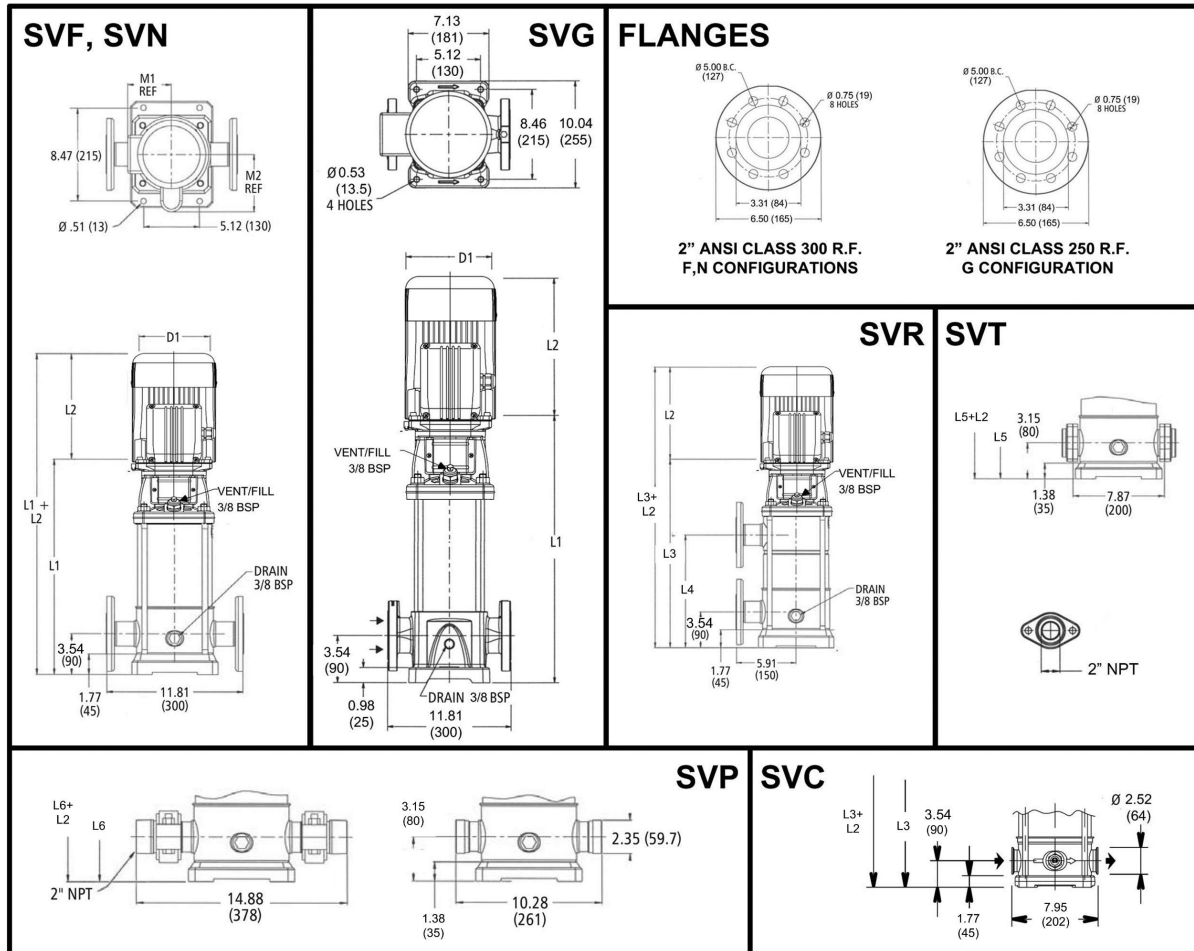

All dimensions are in inches (mm).

PUMP DIMENSIONS AND WEIGHTS - 22SV SERIES – 50Hz, 2900 RPM ODP/TEFC Enclosures

Pump Type Stages	Motor					Dimensions (in)											Weight (lbs.)												
	HP	NEMA Frame		L1	L2					L3	L4	L5	L6	M (Ref.)	D1 (max.)				D2	Pump	Motor				Pump/Motor				
		ODP 1Ø	TEFC 1Ø		ODP 3Ø	TEFC 3Ø	ODP 1Ø	TEFC 1Ø	ODP 3Ø						TEFC 3Ø	ODP 1Ø	TEFC 1Ø	ODP 3Ø			TEFC 3Ø	ODP 1Ø	TEFC 1Ø	ODP 3Ø	TEFC 3Ø	ODP 1Ø	TEFC 1Ø	ODP 3Ø	TEFC 3Ø
22SV-02	5	213TC		184TC		18.71	13.88	15.53	13.93	15.43	18.71	-	18.32	18.32	8.05	8.89	10.62	8.88	8.86	5.51	45	100	120	75	85	145	165	120	130
22SV-03						20.60	13.88	15.53	13.93	15.43	20.60	-	20.21	20.21	8.05	8.89	10.62	8.88	8.86	5.51	48	100	120	75	85	148	168	123	133
22SV-04	7.5	215TC		213TC	215TC	23.06	16.63	16.68	15.55	15.51	23.06	11.85	22.67	22.67	8.77	10.62	10.18	10.18	10.28	5.51	58	132	145	107	122	190	203	165	180
22SV-05				24.97	16.63	16.68	15.55	15.51	24.97	13.74	24.58	24.58	8.77	10.62	10.18	10.18	10.28	5.51	61	132	145	107	122	193	206	168	183		
22SV-06	10	215TC		254TC	27.49	-	-	15.55	16.57	27.49	15.63	27.10	27.10	9.22	-	-	10.18	10.28	5.51	69	-	-	125	195	-	-	194	264	
22SV-07					29.38	-	-	15.55	16.57	29.38	17.52	28.99	28.99	9.22	-	-	10.18	10.28	5.51	72	-	-	125	195	-	-	197	267	
22SV-08	15	254TC		256TC	31.27	-	-	16.66	20.08	31.27	19.41	30.88	30.88	9.5	-	-	10.18	13.13	5.51	75	-	-	144	285	-	-	219	360	
22SV-09					33.16	-	-	16.66	20.08	33.16	21.30	32.77	32.77	9.5	-	-	10.18	13.13	5.51	77	-	-	144	285	-	-	221	362	
22SV-10	15	254TC		256TC	35.05	-	-	16.66	20.08	35.05	23.19	34.66	34.66	9.5	-	-	10.18	13.13	5.51	81	-	-	144	285	-	-	225	366	
22SV-11					36.94	-	-	16.66	20.08	36.94	25.08	-	36.55	9.5	-	-	10.18	13.13	5.51	84	-	-	144	285	-	-	228	369	
22SV-12					38.83	-	-	16.66	20.08	38.83	26.97	-	38.44	9.5	-	-	10.18	13.13	5.51	87	-	-	144	285	-	-	231	372	

Performance Curve

22SV 50 Hz 2900 RPM

LOW NPSH CURVE

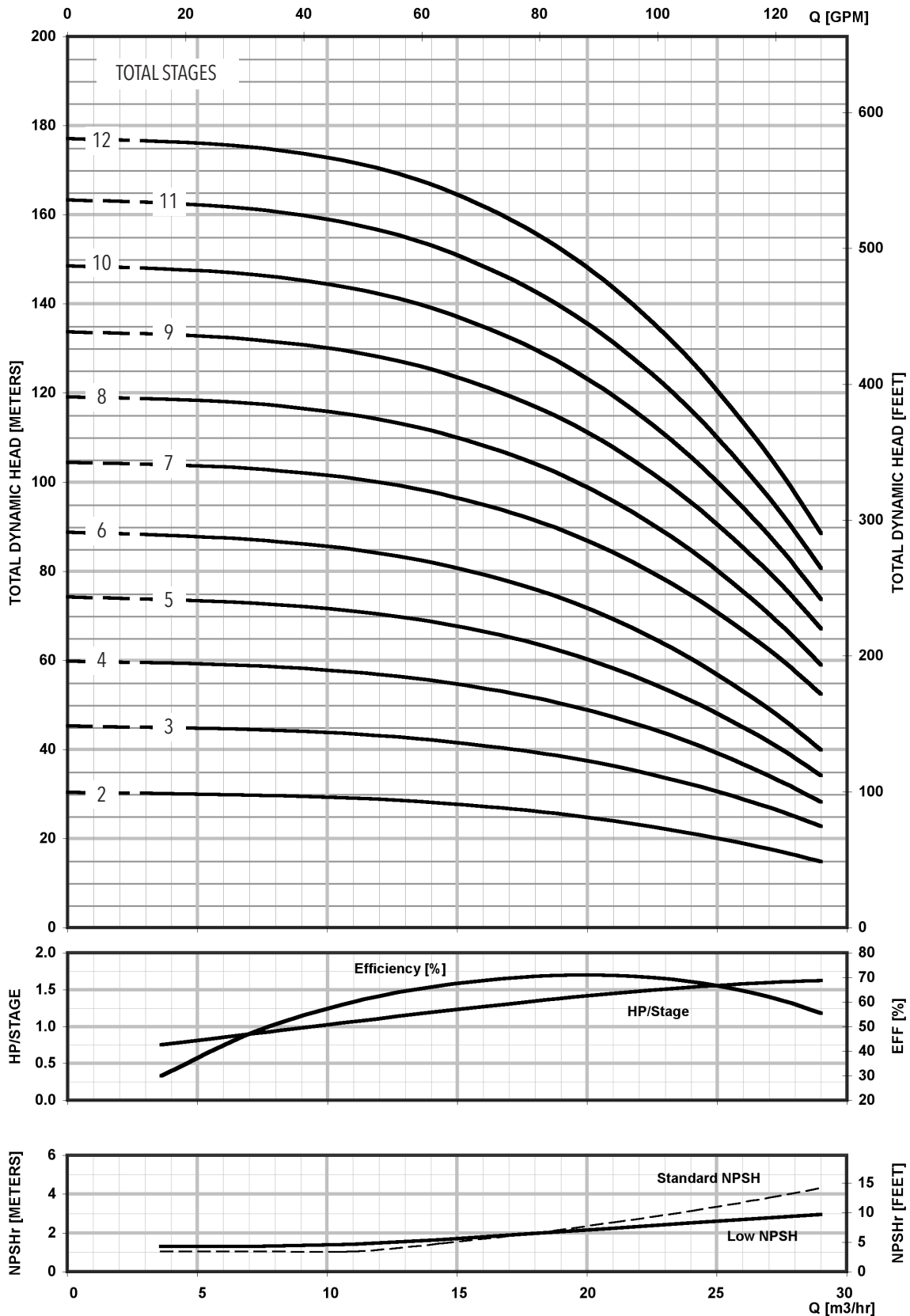

MINIMUM FLOW RATE: 4.1 m³/hr [18 GPM]

Commercial Water

Dimensions and Weights

33SV Series 2900 RPM

LOW NPSH

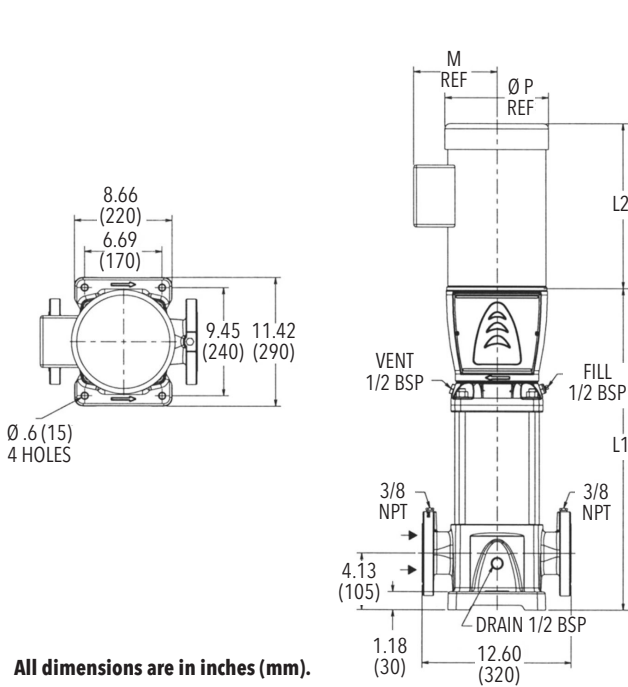

All dimensions are in inches (mm).

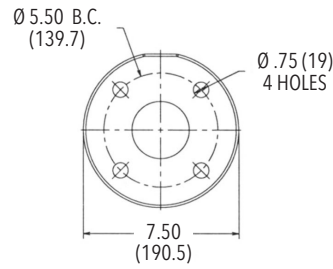

Cast Iron
2 1/2" Class 125 F.F.

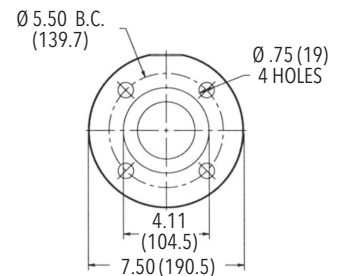

316SS
2 1/2" Class 150 R.F.

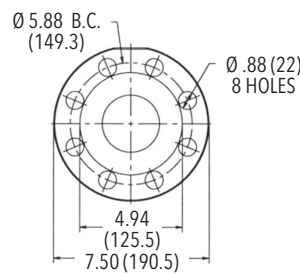

Cast Iron
2 1/2" Class 250 R.F.

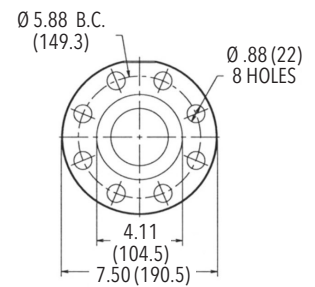

316SS
2 1/2" Class 300 R.F.

Pump Type Stages	Motor					Dimensions (in)										Weight (lbs.)									
	HP	NEMA Frame				L1	L2				M (Ref.)	D1 (max.)				D2	Pump Only	Motor				Pump/Motor			
		ODP 1Ø	TEFC 1Ø	ODP 3Ø	TEFC 3Ø		ODP 1Ø	TEFC 1Ø	ODP 3Ø	TEFC 3Ø		ODP 1Ø	TEFC 1Ø	ODP 3Ø	TEFC 3Ø			ODP 1Ø	TEFC 1Ø	ODP 3Ø	TEFC 3Ø	ODP 1Ø	TEFC 1Ø	ODP 3Ø	TEFC 3Ø
33SV-2/1	7.5	215TC	215TC	213TC	215TC	23.58	16.63	16.68	15.55	15.51	8.77	10.62	10.18	10.18	10.28	5.51	143	132	145	107	122	275	288	250	265
33SV-2						23.58	16.63	16.68	15.55	15.51	8.77	10.62	10.18	10.18	10.28	5.51	143	132	145	107	122	275	288	250	265
33SV-3/2	10			215TC	254TC	26.54	-	-	15.55	16.57	9.22	-	-	10.18	10.28	5.51	152	-	-	125	195	-	-	277	347
33SV-3/1						26.54	-	-	15.55	16.57	9.22	-	-	10.18	10.28	5.51	152	-	-	125	195	-	-	277	347
33SV-3						26.54	-	-	15.55	16.57	9.22	-	-	10.18	10.28	5.51	152	-	-	125	195	-	-	277	347
33SV-4/2	15			254TC	256TC	29.50	-	-	16.66	20.08	9.5	-	-	10.18	13.13	5.51	161	-	-	144	285	-	-	305	446
33SV-4/1						29.50	-	-	16.66	20.08	9.5	-	-	10.18	13.13	5.51	161	-	-	144	285	-	-	305	446
33SV-4						29.50	-	-	16.66	20.08	9.5	-	-	10.18	13.13	5.51	161	-	-	144	285	-	-	305	446
33SV-5/2						32.44	-	-	16.66	20.08	9.5	-	-	10.18	13.13	5.51	172	-	-	144	285	-	-	316	457
33SV-5/1						32.44	-	-	16.66	20.08	9.5	-	-	10.18	13.13	5.51	172	-	-	144	285	-	-	316	457
33SV-5						32.44	-	-	16.66	20.08	9.5	-	-	10.18	13.13	5.51	172	-	-	144	285	-	-	316	457
33SV-6/2						20			254TC	284TC	35.40	-	-	21.44	19.54	12.94	-	-	11.63	12.94	5.51	194	-	-	185
33SV-6/1	35.40	-	-	21.44	19.54						12.94	-	-	11.63	12.94	5.51	194	-	-	185	283	-	-	379	477
33SV-6	35.40	-	-	21.44	19.54						12.94	-	-	11.63	12.94	5.51	194	-	-	185	283	-	-	379	477
33SV-7/2	38.35	-	-	21.44	19.54						12.94	-	-	11.63	12.94	5.51	204	-	-	185	283	-	-	389	487
33SV-7/1	38.35	-	-	21.44	19.54						12.94	-	-	11.63	12.94	5.51	204	-	-	185	283	-	-	389	487
33SV-7	38.35	-	-	21.44	19.54						12.94	-	-	11.63	12.94	5.51	204	-	-	185	283	-	-	389	487
33SV-8/2	25			284TC	286TC						41.30	-	-	21.75	19.54	12.21	-	-	13.25	12.94	5.51	221	-	-	296
33SV-8/1						41.30	-	-	21.75	19.54	12.21	-	-	13.25	12.94	5.51	221	-	-	296	382	-	-	517	603
33SV-8						41.30	-	-	21.75	19.54	12.21	-	-	13.25	12.94	5.51	221	-	-	296	382	-	-	517	603
33SV-9/2						44.25	-	-	21.75	19.54	12.21	-	-	13.25	12.94	5.51	230	-	-	296	382	-	-	526	612
33SV-9/1						44.25	-	-	21.75	19.54	12.21	-	-	13.25	12.94	5.51	230	-	-	296	382	-	-	526	612
33SV-9						44.25	-	-	21.75	23.18	13.11	-	-	13.25	15.56	5.51	230	-	-	315	446	-	-	545	676
33SV-10/2						30			286TC	286TC	47.20	-	-	21.75	23.18	13.11	-	-	13.25	15.56	5.51	249	-	-	315
33SV-10/1	47.20	-	-	21.75	23.18						13.11	-	-	13.25	15.56	5.51	249	-	-	315	446	-	-	564	695
33SV-10	47.20	-	-	21.75	23.18						13.11	-	-	13.25	15.56	5.51	249	-	-	315	446	-	-	564	695

Performance Curve

33SV 50 Hz 2900 RPM

LOW NPSH CURVE

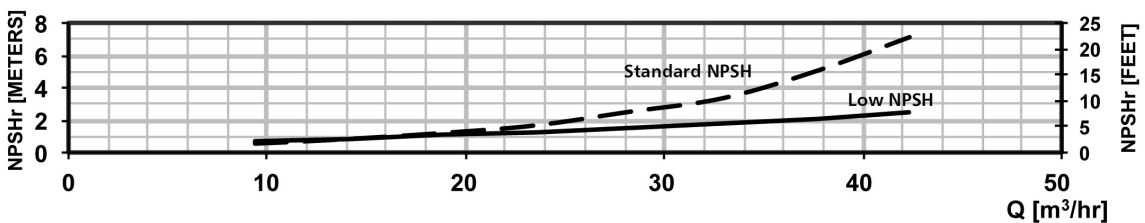
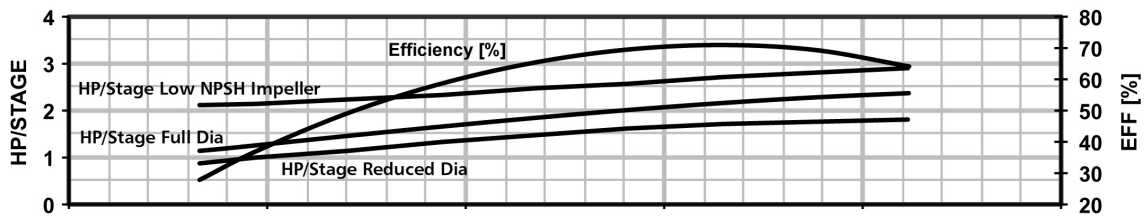
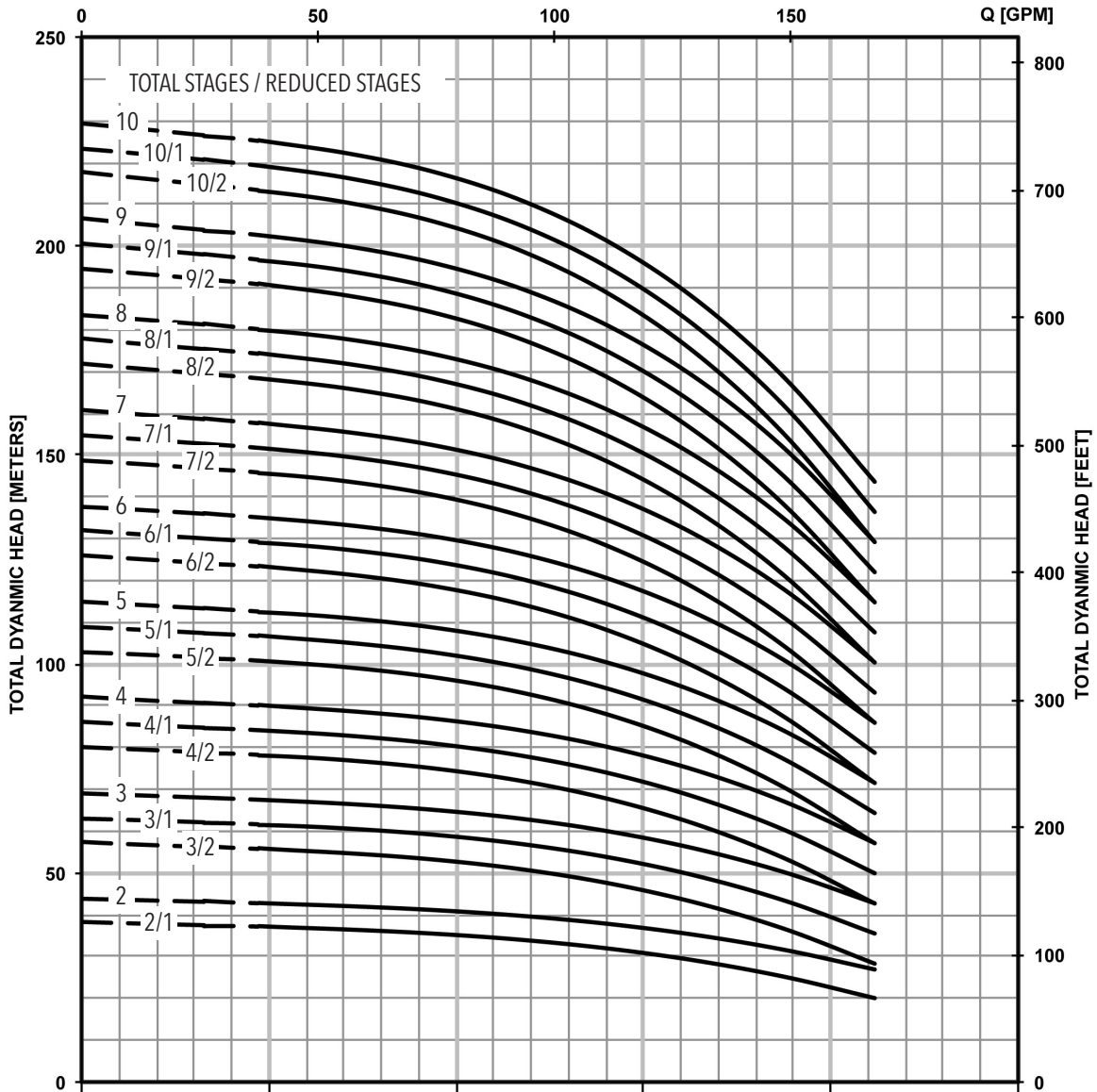

MINIMUM FLOW RATE: 8 m³/hr [35 GPM]

Commercial Water

Dimensions and Weights

46SV Series 2900 RPM

LOW NPSH

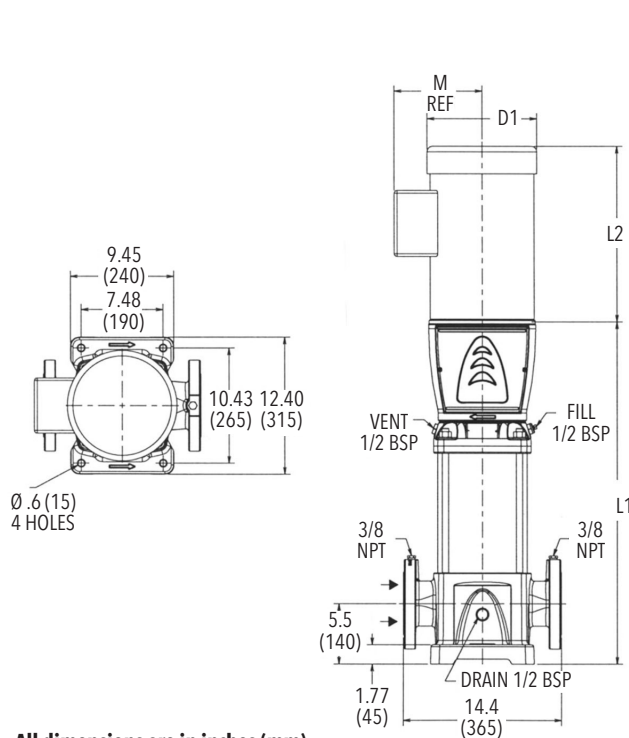

All dimensions are in inches (mm).

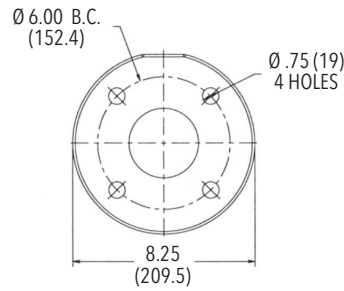

Cast Iron
3" Class 125 F.F.

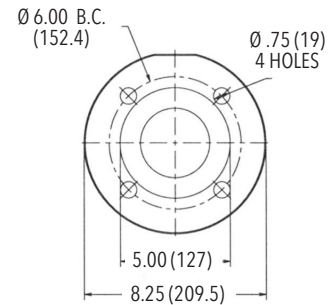

316SS
3" Class 150 R.F.

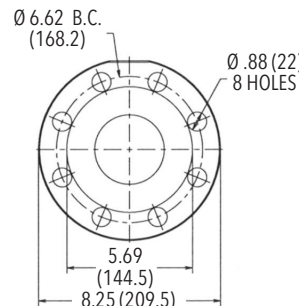

Cast Iron
3" Class 250 R.F.

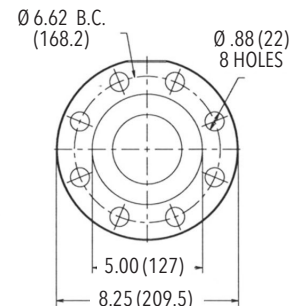

316SS
3" Class 300 R.F.

Pump Type Stages	Motor				Dimensions (in)											Weight (lbs.)									
	HP	NEMA Frame			L1	L2				M (Ref.)	D1 (max.)				D2	Pump Only	Motor				Pump/Motor				
		ODP 1Ø	TEFC 1Ø	ODP 3Ø		TEFC 3Ø	ODP 1Ø	TEFC 1Ø	ODP 3Ø		TEFC 3Ø	ODP 1Ø	TEFC 1Ø	ODP 3Ø			TEFC 3Ø	ODP 1Ø	TEFC 1Ø	ODP 3Ø	TEFC 3Ø	ODP 1Ø	TEFC 1Ø	ODP 3Ø	TEFC 3Ø
46SV-2/1	10	-	-	215TC	254TC	25.19	-	-	15.55	16.57	9.22	-	-	10.18	10.28	5.51181	158	-	-	125	195	-	-	283	353
46SV-2		-	-			25.19	-	-	15.55	16.57	9.22	-	-	10.18	10.28	5.51181	158	-	-	125	195	-	-	283	353
46SV-3/2	15	-	-	254TC	256TC	28.12	-	-	16.66	20.08	9.5	-	-	10.18	13.13	5.51181	169	-	-	144	285	-	-	313	454
46SV-3/1		-	-			28.12	-	-	16.66	20.08	9.5	-	-	10.18	13.13	5.51181	169	-	-	144	285	-	-	313	454
46SV-3		-	-			28.12	-	-	16.66	20.08	9.5	-	-	10.18	13.13	5.51181	169	-	-	144	285	-	-	313	454
46SV-4/2		-	-			32.63	-	-	21.44	19.54	12.94	-	-	11.63	12.94	5.51181	185	-	-	185	283	-	-	370	468
46SV-4/1	20	-	-	254TC	284TC	32.63	-	-	21.44	19.54	12.94	-	-	11.63	12.94	5.51181	185	-	-	185	283	-	-	370	468
46SV-4		-	-			32.63	-	-	21.44	19.54	12.94	-	-	11.63	12.94	5.51181	185	-	-	185	283	-	-	370	468
46SV-5/2		-	-			35.56	-	-	21.44	19.54	12.94	-	-	11.63	12.94	5.51181	199	-	-	185	283	-	-	384	482
46SV-5/1		-	-			35.56	-	-	21.44	19.54	12.94	-	-	11.63	12.94	5.51181	199	-	-	185	283	-	-	384	482
46SV-5		-	-			35.56	-	-	21.75	19.54	12.21	-	-	13.25	12.94	5.51181	199	-	-	296	382	-	-	495	581
46SV-6/2		25	-			-	284TC	286TC	38.50	-	-	21.75	19.54	12.21	-	-	13.25	12.94	5.51181	208	-	-	296	382	-
46SV-6/1	-		-	38.50	-	-			21.75	19.54	12.21	-	-	13.25	12.94	5.51181	208	-	-	296	382	-	-	504	590
46SV-6	30	-	-	286TC	286TC	38.50	-	-	21.75	23.18	13.11	-	-	13.25	15.56	5.51181	208	-	-	315	446	-	-	523	654
46SV-7/2		-	-			40.94	-	-	21.75	23.18	13.11	-	-	13.25	15.56	5.51181	225	-	-	315	446	-	-	540	671
46SV-7/1		-	-			40.94	-	-	21.75	23.18	13.11	-	-	13.25	15.56	5.51181	225	-	-	315	446	-	-	540	671
46SV-7		-	-			40.94	-	-	21.75	23.18	13.11	-	-	13.25	15.56	5.51181	225	-	-	315	446	-	-	540	671
46SV-8/2	40	-	-	324TSC	326TSC	43.94	-	-	22.75	23.19	12.21	-	-	13.03	15.69	0	234	-	-	320	450	-	-	554	684
46SV-8/1		-	-			43.94	-	-	22.75	23.19	12.21	-	-	13.03	15.69	0	234	-	-	320	450	-	-	554	684
46SV-8		-	-			43.94	-	-	22.75	23.19	12.21	-	-	13.03	15.69	0	234	-	-	320	450	-	-	554	684
46SV-9/2		-	-			46.88	-	-	22.75	23.19	12.21	-	-	13.03	15.69	0	253	-	-	320	450	-	-	573	703
46SV-9/1		-	-			46.88	-	-	22.75	23.19	12.21	-	-	13.03	15.69	0	253	-	-	320	450	-	-	573	703
46SV-9		-	-			46.88	-	-	22.75	23.19	12.21	-	-	13.03	15.69	0	253	-	-	320	450	-	-	573	703
46SV-10/2	-	-	49.81	-	-	22.75	23.19	12.21	-	-	13.03	15.69	0	264	-	-	320	450	-	-	584	714			

Performance Curve

46SV 50 Hz 2900 RPM

LOW NPSH CURVE

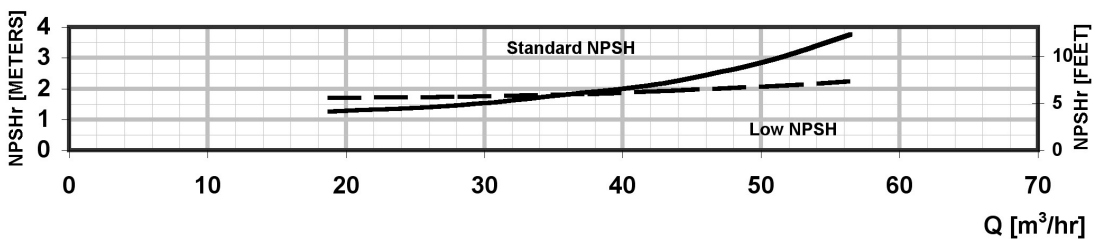
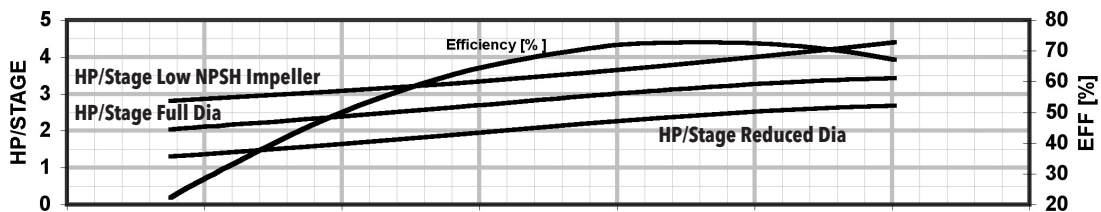
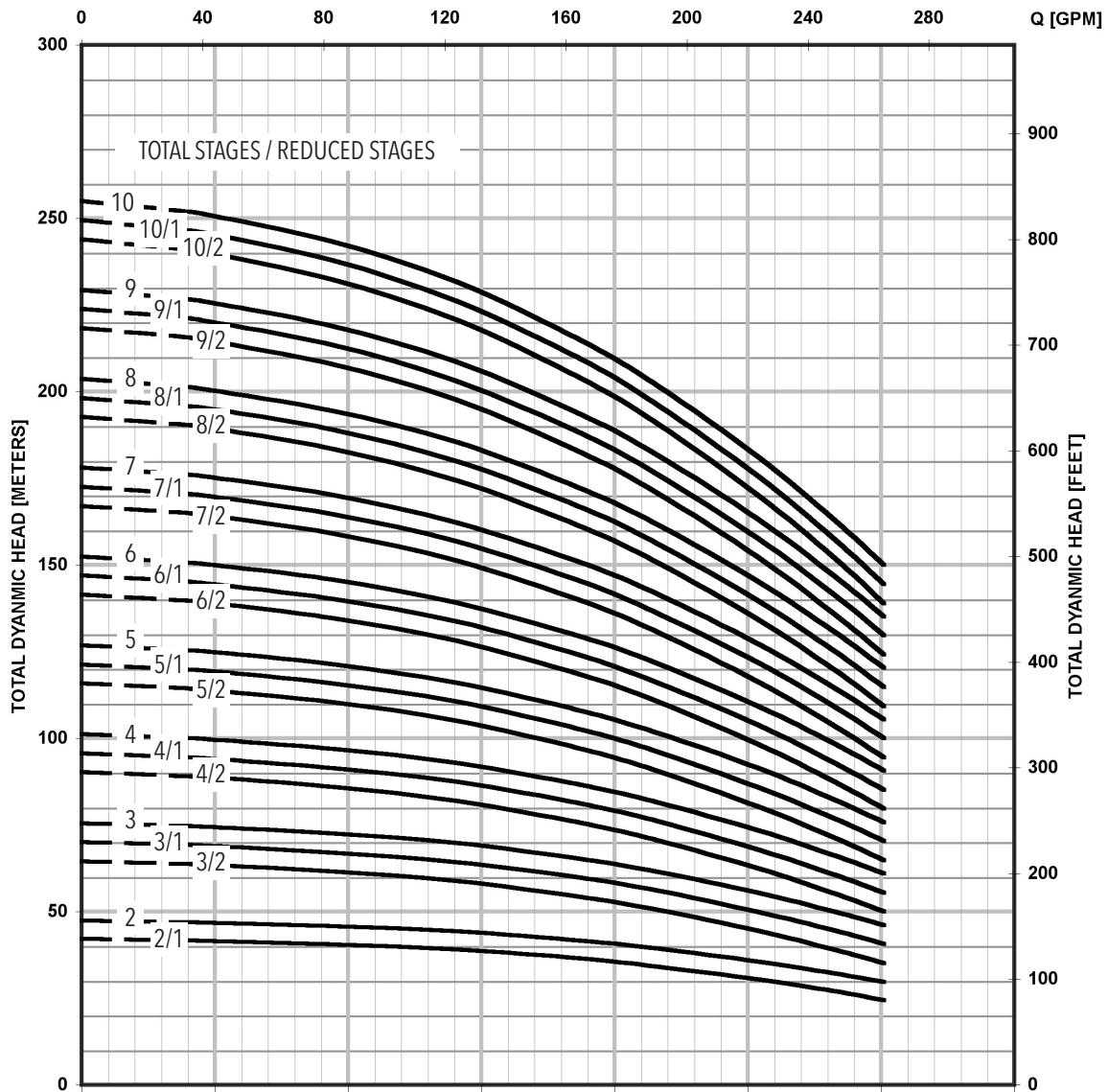

MINIMUM FLOW RATE: 9 m³/hr [40 GPM]

Commercial Water

Dimensions and Weights

66SV Series 2900 RPM

LOW NPSH

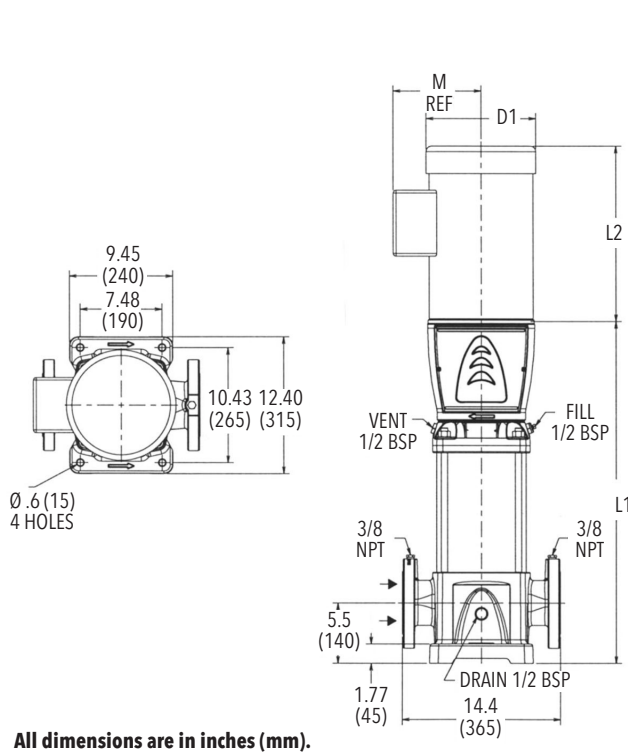

All dimensions are in inches (mm).

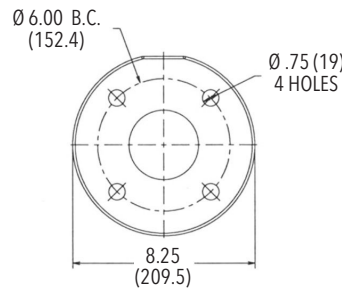

Cast Iron
3" Class 125 F.F.

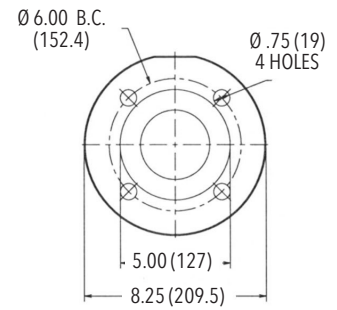

316SS
3" Class 150 R.F.

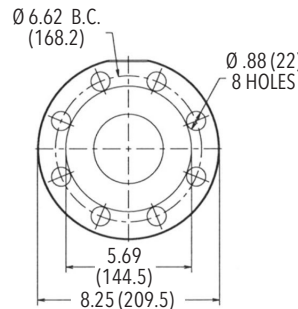

Cast Iron
3" Class 250 R.F.

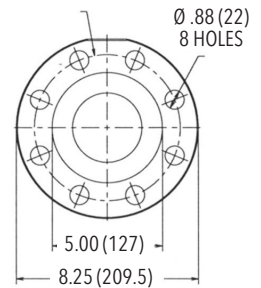

316SS
3" Class 300 R.F.

Pump Type Stages	Motor				Dimensions (in)										Weight (lbs.)										
	HP	NEMA Frame			L1	L2				M (Ref.)	D1 (max.)				D2	Pump Only	Motor				Pump/Motor				
		ODP 1Ø	TEFC 1Ø	ODP 3Ø		TEFC 3Ø	ODP 1Ø	TEFC 1Ø	ODP 3Ø		TEFC 3Ø	ODP 1Ø	TEFC 1Ø	ODP 3Ø			TEFC 3Ø	ODP 1Ø	TEFC 1Ø	ODP 3Ø	TEFC 3Ø	ODP 1Ø	TEFC 1Ø	ODP 3Ø	TEFC 3Ø
66SV-2/1	-	-	-	-	26.75	-	-	16.66	20.08	9.5	-	-	10.18	13.13	5.51181	196	-	-	144	285	-	-	340	481	
66SV-2	15	-	-	254TC	256TC	26.75	-	-	16.66	20.08	9.5	-	-	10.18	13.13	5.51181	196	-	-	144	285	-	-	340	481
66SV-3/2	-	-	-	-	31.81	-	-	16.66	20.08	9.5	-	-	10.18	13.13	5.51181	223	-	-	144	285	-	-	367	508	
66SV-3/1	20	-	-	254TC	284TC	31.81	-	-	21.44	19.54	12.94	-	-	11.63	12.94	5.51181	223	-	-	185	283	-	-	408	506
66SV-3	-	-	-	-	31.81	-	-	21.44	19.54	12.94	-	-	11.63	12.94	5.51181	223	-	-	185	283	-	-	408	506	
66SV-4/2	-	-	-	-	35.38	-	-	21.75	19.54	12.21	-	-	13.25	12.94	5.51181	234	-	-	296	382	-	-	530	616	
66SV-4/1	25	-	-	284TC	286TC	35.38	-	-	21.75	19.54	12.21	-	-	13.25	12.94	5.51181	234	-	-	296	382	-	-	530	616
66SV-4	-	-	-	-	35.38	-	-	21.75	19.54	12.21	-	-	13.25	12.94	5.51181	234	-	-	296	382	-	-	530	616	
66SV-5/2	-	-	-	-	39.44	-	-	21.75	23.18	13.11	-	-	13.25	15.56	5.51181	244	-	-	315	446	-	-	559	690	
66SV-5/1	30	-	-	286TC	286TC	39.44	-	-	21.75	23.18	13.11	-	-	13.25	15.56	5.51181	244	-	-	315	446	-	-	559	690
66SV-5	-	-	-	-	39.44	-	-	22.75	23.19	12.21	-	-	13.03	15.69	0	244	-	-	320	450	-	-	564	694	
66SV-6/2	-	-	-	-	41.94	-	-	22.75	23.19	12.21	-	-	13.03	15.69	0	266	-	-	320	450	-	-	586	716	
66SV-6/1	40	-	-	324TSC	326TSC	41.94	-	-	22.75	23.19	12.21	-	-	13.03	15.69	0	266	-	-	320	450	-	-	586	716
66SV-6	-	-	-	-	41.94	-	-	22.75	23.19	12.21	-	-	13.03	15.69	0	266	-	-	320	450	-	-	586	716	

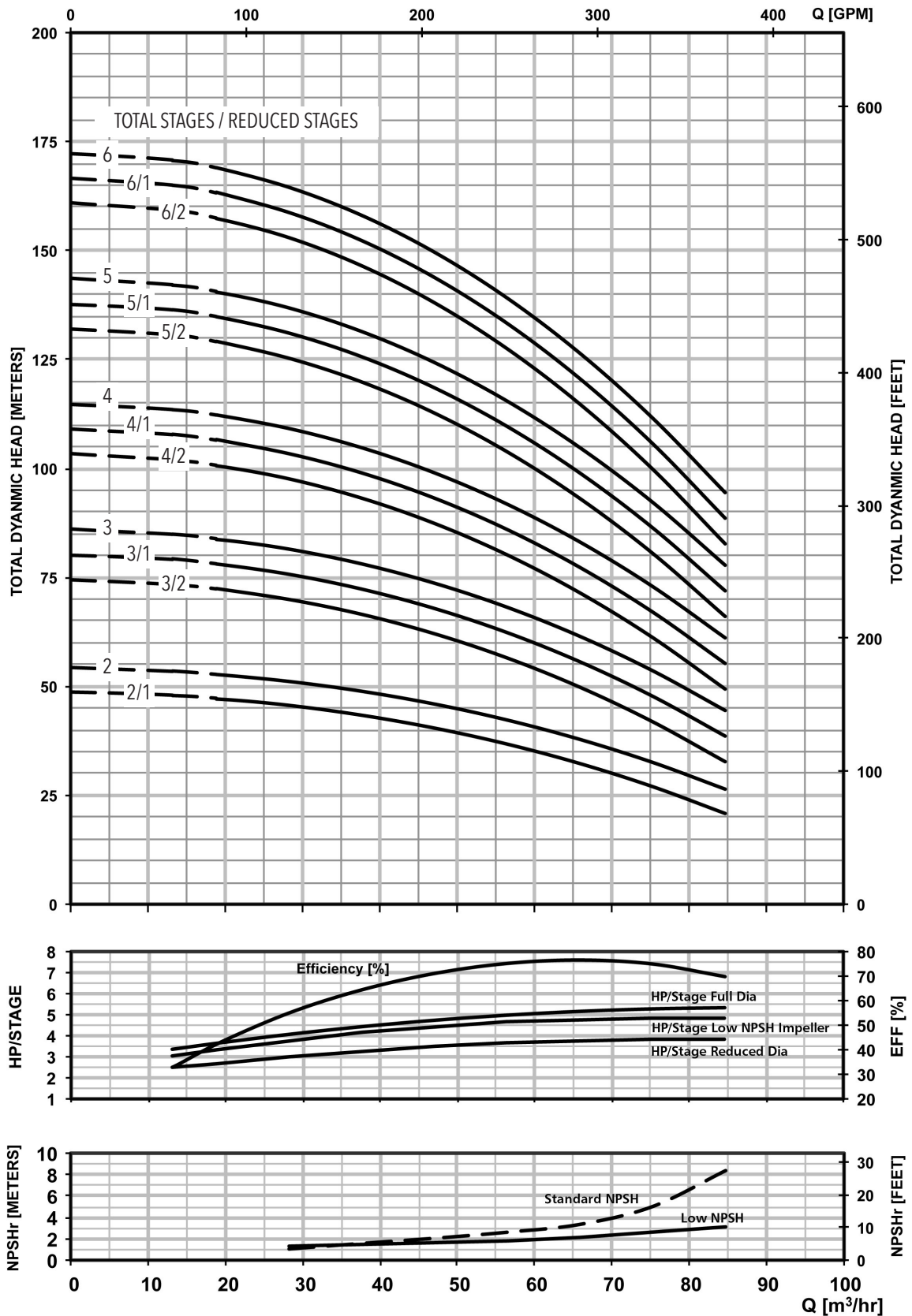

MINIMUM FLOW RATE: 16 m³/hr [70 GPM]

Technical Data - Pump Hydraulics / Motor Sizing

1SV 3500 RPM

No. of Impellers	Maximum HP draw	Motor Selection using SF				Motor Selection 1.0 SF				Shutoff TDH (Feet)	Shutoff TDH (psi)	Shutoff TDH (Bar)	Casing/Sleeve Pressure Rating (standard assy.)	Pump Flange Rating	
		Rated HP	NEMA Motor Frame		Rated HP	NEMA Motor Frame									
			ODP	TEFC		ODP	TEFC								
30	3.52	5.00	184TC	184TC	5.00	184TC	184TC	860	372	25.7	40 Bar (580 psi)	Class 250 / 300			
29	3.41	3.00	56C	56C		184TC	184TC	835	362	24.9					
28	3.29		56C	56C		184TC	184TC	810	351	24.2					
27	3.18		56C	56C		184TC	184TC	780	338	23.3					
26	3.06		56C	56C		184TC	184TC	750	325	22.4					
25	2.95		56C	56C	3.00	56C	56C	720	312	21.5					
24	2.83		56C	56C		56C	56C	695	301	20.7					
23	2.72		56C	56C		56C	56C	665	288	19.8					
22	2.60		56C	56C		56C	56C	635	275	18.9					
21	2.49		56C	56C		56C	56C	610	264	18.2					
20	2.37		56C	56C		56C	56C	580	251	17.3					
19	2.26	2.00	56C	56C		2.00	56C	56C	550	238	16.4				
18	2.14		56C	56C			56C	56C	520	225	15.5				
17	2.03		56C	56C			56C	56C	485	210	14.5				
16	1.91		56C	56C			56C	56C	455	197	13.6				
15	1.80		56C	56C	56C		56C	425	184	12.7					
14	1.68		1.50	56C	56C		1.50	56C	56C	400	173		11.9		
13	1.57			56C	56C			56C	56C	375	162		11.2		
12	1.45			56C	56C			56C	56C	345	149		10.3		
11	1.34			56C	56C			56C	56C	315	136		9.4		
10	1.22			56C	56C			56C	56C	290	126		8.7		
9	1.11	1.00		56C	56C	1.00		56C	56C	255	110		7.6		
8	0.99			56C	56C			56C	56C	230	100		6.9		
7	0.88			56C	56C			56C	56C	200	87		6.0		
6	0.76			0.75	56C			56C	0.75	56C	56C		175	76	5.2
5	0.65				56C			56C		56C	56C		145	63	4.3
4	0.53		56C		56C		56C	56C		115	50		3.4		
3	0.42		56C		56C		0.50	56C		56C	87		37	2.5	

Commercial Water

Technical Data - Pump Hydraulics / Motor Sizing

3SV 3500 RPM

No. of Impellers	Maximum HP draw	Motor Selection using SF				Motor Selection 1.0 SF			Shutoff TDH (Feet)	Shutoff TDH (psi)	Shutoff TDH (Bar)	Casing/Sleeve Pressure Rating (standard assy.)	Pump Flange Rating						
		Rated HP	NEMA Motor Frame		Rated HP	NEMA Motor Frame													
			ODP	TEFC		ODP	TEFC												
30	6.32	7.50	213TC	213TC	7.50	213TC	213TC	1085	470	32.4	40 Bar (580 psi)	Class 250 / 300							
29	6.11		213TC	213TC		213TC	213TC	1050	455	31.3									
28	5.90		213TC	213TC		213TC	213TC	1015	440	30.3									
27	5.70	5.00	184TC	184TC	5.00	213TC	213TC	975	422	29.1			40 Bar (580 psi)	Class 250 / 300					
26	5.49		184TC	184TC		213TC	213TC	940	407	28.0									
25	5.28		184TC	184TC		213TC	213TC	900	390	26.9									
24	5.07		184TC	184TC		213TC	213TC	865	375	25.8									
23	4.86		184TC	184TC		184TC	184TC	825	357	24.6									
22	4.66		184TC	184TC		184TC	184TC	795	344	23.7									
21	4.45		184TC	184TC		184TC	184TC	760	329	22.7									
20	4.24	3.00	184TC	184TC	5.00	184TC	184TC	720	312	21.5	25 Bar (362 psi)		Class 250 / 300						
19	4.03		184TC	184TC		184TC	184TC	680	294	20.3									
18	3.82		184TC	184TC		184TC	184TC	645	279	19.2									
17	3.62		184TC	184TC		184TC	184TC	610	264	18.2									
16	3.41		3.00	56C		56C	3.00	184TC	184TC	575					249	17.2	25 Bar (362 psi)	Class 250 / 300	
15	3.20			56C		56C		184TC	184TC	540					234	16.1			
14	2.99			56C		56C		56C	56C	500					217	14.9			
13	2.78	2.00	56C	56C	2.00	56C	56C	465	201	13.9	25 Bar (362 psi)				Class 250 / 300				
12	2.58		56C	56C		56C	56C	430	186	12.8									
11	2.37		56C	56C		56C	56C	395	171	11.8									
10	2.16	2.00	56C	56C	2.00	56C	56C	360	156	10.7	25 Bar (362 psi)					Class 250 / 300			
9	1.95		56C	56C		56C	56C	320	139	9.5									
8	1.74		56C	56C		56C	56C	285	123	8.5									
7	1.54	1.50	56C	56C	1.50	56C	56C	250	108	7.5	25 Bar (362 psi)						Class 250 / 300		
6	1.33		56C	56C		56C	56C	215	93	6.4									
5	1.12		56C	56C		56C	56C	180	78	5.4									
4	0.91	1.00	56C	56C	1.00	56C	56C	145	63	4.3	25 Bar (362 psi)								Class 250 / 300
3	0.70		0.75	56C		56C	0.75	56C	56C	105									

Commercial Water

Technical Data - Pump Hydraulics / Motor Sizing

5SV 3500 RPM

No. of Impellers	Maximum HP draw	Motor Selection using SF				Motor Selection 1.0 SF			Shutoff TDH (Feet)	Shutoff TDH (psi)	Shutoff TDH (Bar)	Casing/Sleeve Pressure Rating (standard assy.)	Pump Flange Rating
		Rated HP	NEMA Motor Frame		Rated HP	NEMA Motor Frame							
			ODP	TEFC		ODP	TEFC						
27	9.24	10.00	215TC	215TC	10.00	215TC	215TC	975	422	29.1	40 Bar (580 psi)	Class 250 / 300	
26	8.92		215TC	215TC		215TC	215TC	940	407	28.0			
25	8.59		215TC	215TC		215TC	215TC	900	390	26.9			
24	8.26	7.50	213TC	213TC	7.50	215TC	215TC	865	375	25.8			25 Bar (362 psi)
23	7.94		213TC	213TC		215TC	215TC	825	357	24.6			
22	7.61		213TC	213TC		215TC	215TC	785	340	23.4			
21	7.29		213TC	213TC		213TC	213TC	745	323	22.2			
20	6.96		213TC	213TC		213TC	213TC	715	310	21.3			
19	6.63		213TC	213TC		213TC	213TC	685	297	20.4			
18	6.31	5.00	213TC	213TC	5.00	213TC	213TC	650	282	19.4			
17	5.98		213TC	213TC		213TC	213TC	615	266	18.4			
16	5.66		184TC	184TC		213TC	213TC	575	249	17.2			
15	5.33		184TC	184TC		213TC	213TC	540	234	16.1			
14	5.00		184TC	184TC		184TC	184TC	505	219	15.1			
13	4.68		184TC	184TC		184TC	184TC	470	204	14.0			
12	4.35	3.00	184TC	184TC	3.00	184TC	184TC	430	186	12.8			
11	4.03		184TC	184TC		184TC	184TC	395	171	11.8			
10	3.70		184TC	184TC		184TC	184TC	360	156	10.7			
9	3.37		56C	56C		184TC	184TC	320	139	9.5			
8	3.05		56C	56C		184TC	184TC	300	123	8.5			
7	2.72		56C	56C		56C	56C	260	108	7.5			
6	2.40	2.00	56C	56C	2.00	56C	56C	230	95	6.6			
5	2.07		56C	56C		56C	56C	195	78	5.4			
4	1.74		56C	56C		56C	56C	160	63	4.3			
3	1.42	56C	56C	1.50	56C	56C	120	48	3.3				

10SV 3500 RPM

No. of Impellers	Maximum HP draw	Motor Selection using SF				Motor Selection 1.0 SF			Shutoff TDH (Feet)	Shutoff TDH (psi)	Shutoff TDH (Bar)	Casing/Sleeve Pressure Rating (standard assy.)	Pump Flange Rating
		Rated HP	NEMA Motor Frame		Rated HP	NEMA Motor Frame							
			ODP	TEFC		ODP	TEFC						
20	19.79	20.00	254TC	256TC	20.00	254TC	256TC	1150	498	34.3	40 Bar (580 psi)	VICTAULIC	
19	18.90		254TC	256TC		254TC	256TC	1095	474	32.7			
18	18.01		254TC	256TC		254TC	256TC	1035	448	30.9			
17	17.11	15.00	215TC	254TC	15.00	254TC	256TC	975	422	29.1		25 Bar (362 psi)	
16	16.22		215TC	254TC		254TC	256TC	920	398	27.5			
15	15.33		215TC	254TC		254TC	256TC	860	372	25.7			
14	14.44		215TC	254TC		215TC	254TC	805	349	24.0			
13	13.55		215TC	254TC		215TC	254TC	745	323	22.2			
12	12.65		215TC	254TC		215TC	254TC	690	299	20.6			
11	11.76	10.00	215TC	254TC	10.00	215TC	254TC	630	273	18.8			
10	10.87		215TC	215TC		215TC	254TC	575	249	17.2			
9	9.98		215TC	215TC		215TC	215TC	520	225	15.5			
8	9.09		215TC	215TC		215TC	215TC	460	199	13.7			
7	8.19		213TC	213TC		215TC	215TC	400	173	11.9			
6	7.30		7.50	213TC		213TC	7.50	213TC	213TC	340	147		10.1
5	6.41	213TC		213TC	213TC	213TC		285	123	8.5			
4	5.52	184TC		184TC	213TC	213TC		225	97	6.7			
3	4.63	5.00	184TC	184TC	5.00	184TC	184TC	170	74	5.1			
2	3.73		184TC	184TC		184TC	184TC	115	50	3.4			

Commercial Water

Technical Data - Pump Hydraulics / Motor Sizing

15SV 3500 RPM

No. of Impellers	Maximum HP draw	Motor Selection using SF				Motor Selection 1.0 SF				Shutoff TDH (Feet)	Shutoff TDH (psi)	Shutoff TDH (Bar)	Casing/Sleeve Pressure Rating (standard assy.)	Pump Flange Rating
		Rated HP	NEMA Motor Frame		Rated HP	NEMA Motor Frame								
			ODP	TEFC		ODP	TEFC							
15	30.27	30.00	284TC	286TC	40.00	286TC	286TC	1060	459	31.6	40 Bar (580 psi)	Class 250 / 300		
14	28.37	25.00	254TC	284TC	30.00	284TC	286TC	990	429	29.5				
13	26.47		254TC	284TC		284TC	286TC	915	396	27.3				
12	24.57		254TC	284TC		254TC	284TC	850	368	25.4				
11	22.67	20.00	254TC	256TC	25.00	254TC	284TC	780	338	23.3				
10	20.77		254TC	256TC		254TC	284TC	705	305	21.0				
9	18.87		254TC	256TC		254TC	256TC	635	275	18.9				
8	16.97	15.00	215TC	254TC	20.00	254TC	256TC	565	245	16.9				
7	15.07		215TC	254TC		254TC	256TC	485	210	14.5				
6	13.17		215TC	254TC		15.00	215TC	254TC	420	182	12.5			
5	11.27	10.00	215TC	215TC	215TC		254TC	345	149	10.3				
4	9.37		215TC	215TC	215TC		215TC	275	119	8.2				
3	7.47		7.50	213TC	213TC	7.50	213TC	213TC	210	91	6.3			
2	5.57	5.00	184TC	184TC	213TC		213TC	140	61	4.2				

22SV 3500 RPM

No. of Impellers	Maximum HP draw	Motor Selection using SF				Motor Selection 1.0 SF				Shutoff TDH (Feet)	Shutoff TDH (psi)	Shutoff TDH (Bar)	Casing/Sleeve Pressure Rating (standard assy.)	Pump Flange Rating
		Rated HP	NEMA Motor Frame		Rated HP	NEMA Motor Frame								
			ODP	TEFC		ODP	TEFC							
12	30.56	30.00	284TC	286TC	40.00	286TC	286TC	880	381	26.3	40 Bar (580 psi)	Class 250 / 300		
11	28.15	25.00	254TC	284TC	30.00	284TC	286TC	810	351	24.2				
10	25.74		254TC	284TC		284TC	286TC	735	318	21.9				
9	23.33		20.00	254TC		256TC	25.00	254TC	284TC	660			286	19.7
8	20.92	254TC		256TC	254TC	284TC		585	253	17.5				
7	18.51	254TC		256TC	20.00	254TC		256TC	515	223	15.4			
6	16.10	15.00	215TC	254TC		254TC	256TC	440	191	13.1				
5	13.69		215TC	254TC		15.00	215TC	254TC	365	158	10.9			
4	11.28		10.00	215TC	215TC		215TC	254TC	295	128	8.8			
3	8.87	215TC		215TC	10.00		215TC	215TC	220	95	6.6			
2	6.46	7.50		213TC	213TC	7.50	213TC	213TC	115	106	7.3			

Commercial Water

Technical Data - Pump Hydraulics / Motor Sizing

33SV 3500 RPM

No. of Impellers	Maximum HP draw	Motor Selection using SF		Motor Selection 1.0 SF		Shutoff TDH (Feet)	Shutoff TDH (psi)	Shutoff TDH (Bar)	Casing/Sleeve Pressure Rating (standard assy.)	Pump Flange Rating	Stages Requiring Thrust Balancing Piston		
		Rated HP	NEMA Motor Frame		Rated HP							NEMA Motor Frame	
			ODP	TEFC								ODP	TEFC
10	57.3	50.00	326TSC		60	326TSC	364TSC	1096	475	32.7	40 Bar (580 psi)	Class 250 / 300	Thrust Piston Required
10/1	56.0							1068	462	31.9			
10/2	54.7							1039	450	31.0			
9	51.7							986	427	29.4			
9/1	50.4							958	415	28.6			
9/2	49.1							930	403	27.7			
8	46.1	40.00	284TSC		50	326TSC	877	380	26.2				
8/1	44.8						849	368	25.3				
8/2	43.5						820	355	24.5				
7	40.5						768	332	22.9				
7/1	39.2						739	320	22.1				
7/2	37.9						711	308	21.2				
6	34.9	30.00	284TSC		40	284TSC	658	285	19.6				
6/1	33.6						630	273	18.8				
6/2	32.3						602	261	18.0				
5	29.3						549	238	16.4				
5/1	28.0						521	225	15.5				
5/2	26.7						492	213	14.7				
4	23.7	25.00	256TC	284TC	30	284TC	439	190	13.1				
4/1	22.4		20.00	254TC			256TC	25	256TC	284TC	411	178	12.3
4/2	21.1										383	166	11.4
3	18.1										330	143	9.8
3/1	16.8										302	131	9.0
3/2	15.5										273	118	8.2
2	12.5	221			96	6.6							
2/1	11.2	10.00	213TC	215TC	15	215TC	254TC	192	83	5.7	25 Bar (362 psi)	Class 125 / 150	

Commercial Water

Technical Data - Pump Hydraulics / Motor Sizing

46SV 3500 RPM

No. of Impellers	Maximum HP draw	Motor Selection using SF				Motor Selection 1.0 SF			Shutoff TDH (Feet)	Shutoff TDH (psi)	Shutoff TDH (Bar)	Casing/Sleeve Pressure Rating (standard assy.)	Pump Flange Rating	Stages Requiring Thrust Balancing Piston		
		Rated HP	NEMA Motor Frame		Rated HP	NEMA Motor Frame										
			ODP	TEFC		ODP	TEFC									
9	75.2	75	365TSC		75	365TSC		1095	474	32.7	40 Bar (580 psi)	Class 250 / 300	Thrust Piston Required			
9/1	73.4							1069	463	31.9						
9/2	71.6							1042	451	31.1						
8	67.1	60	326TSC	364TSC	75	365TSC		973	421	29.0						
8/1	65.3							946	410	28.2						
8/2	63.5							920	398	27.4						
7	59.0	50	326TSC		60	326TSC	364TSC	850	368	25.4				25 Bar (362 psi)	Class 125 / 150	
7/1	57.2							824	357	24.6						
7/2	55.4							797	345	23.8						
6	50.9	50	326TSC		50	326TSC		728	315	21.7						
6/1	49.1							701	304	20.9						
6/2	47.3							675	292	20.1						
5	42.8	40	284TSC		40	284TSC		605	262	18.1						
5/1	41.0							579	251	17.3						
5/2	39.2							553	239	16.5						
4	34.7	30	284TSC		40	284TSC		483	209	14.4						
4/1	32.9							457	198	13.6						
4/2	31.1							430	186	12.8						
3	26.6	25	256TC	284TC	30			361	156	10.8						
3/1	24.8		25	256TC	284TC	25	256TC	284TC	334	145	10.0					
3/2	23.0								308	133	9.2					
2	18.5	20	254TC	256TC	20	254TC	256TC	238	103	7.1						
2/1	16.7		215TC	254TC				212	92	6.3						

66SV 3500 RPM

No. of Impellers	Maximum HP draw	Motor Selection using SF				Motor Selection 1.0 SF			Shutoff TDH (Feet)	Shutoff TDH (psi)	Shutoff TDH (Bar)	Casing/Sleeve Pressure Rating (standard assy.)	Pump Flange Rating	Stages Requiring Thrust Balancing Piston		
		Rated HP	NEMA Motor Frame		Rated HP	NEMA Motor Frame										
			ODP	TEFC		ODP	TEFC									
6	74.3	75	365TSC		75.00	365TSC		824	357	24.6	40 Bar (580 psi)	Class 250 / 300	Thrust Piston Required			
6/1	70.7							796	345	23.8						
6/2	67.1							769	333	22.9						
5	61.7	60	326TSC	364TSC	60.00	326TSC	364TSC	686	297	20.5						
5/1	58.1							659	285	19.6						
5/2	54.5							631	273	18.8						
4	49.1	50	326TSC		50.00	326TSC		548	237	16.4				25 Bar (362 psi)	Class 125 / 150	
4/1	45.5							521	226	15.5						
4/2	41.9							494	214	14.7						
3	36.5	40	284TSC		40.00	284TSC		411	178	12.3						
3/1	32.9							383	166	11.4						
3/2	29.3							356	154	10.6						
2	23.9	25	256TC	284TC	25.00	256TC	284TC	273	118	8.1						
2/1	20.3		254TC	256TC				246	106	7.3						

Technical Data - Pump Hydraulics / Motor Sizing

1SV 2900 RPM

No. of Impellers	Maximum HP draw	Motor Selection using SF				Motor Selection 1.0 SF			Shutoff TDH (Meters)	Shutoff TDH (psi)	Shutoff TDH (Bar)	Casing/Sleeve Pressure Rating (standard assy.)	Pump Flange Rating
		Rated HP	NEMA Motor Frame		Rated HP	NEMA Motor Frame							
			ODP	TEFC		ODP	TEFC						
30	2.05	2.00	56C	56C	3.00	184TC	184TC	179	254	17.5	25 Bar (362 psi)	Class 250 / 300	
29	1.98		56C	56C		56C	56C	172	244	16.8			
28	1.91		56C	56C		56C	56C	167	237	16.3			
27	1.85		56C	56C		56C	56C	161	228	15.8			
26	1.78		56C	56C		56C	56C	155	220	15.2			
25	1.71		56C	56C		56C	56C	149	212	14.6			
24	1.65	1.50	56C	56C	2.00	56C	56C	143	203	14.0			
23	1.58		56C	56C		56C	56C	137	195	13.4			
22	1.50		56C	56C		56C	56C	133	188	13.0			
21	1.44		56C	56C		56C	56C	127	180	12.4			
20	1.37		56C	56C		56C	56C	121	171	11.8			
19	1.30		56C	56C		56C	56C	115	163	11.2			
18	1.24	1.00	56C	56C	1.50	56C	56C	109	154	10.6			
17	1.17		56C	56C		56C	56C	102	144	10.0			
16	1.11		56C	56C		56C	56C	97	137	9.4			
15	1.03		56C	56C		56C	56C	89	126	8.7			
14	0.97		56C	56C		56C	56C	83	118	8.1			
13	0.90		56C	56C		56C	56C	77	109	7.5			
12	0.84	0.75	56C	56C	1.00	56C	56C	71	101	7.0			
11	0.77		56C	56C		56C	56C	65	92	6.4			
10	0.70		56C	56C		56C	56C	59	84	5.8			
9	0.63		56C	56C		56C	56C	53	75	5.2			
8	0.57		56C	56C		56C	56C	47	67	4.6			
7	0.50		56C	56C		56C	56C	41	59	4.1			
6	0.43	0.50	56C	56C	0.75	56C	56C	36	50	3.5			
5	0.37		56C	56C		56C	56C	29	42	2.9			
4	0.30		56C	56C		56C	56C	24	34	2.3			
3	0.24		56C	56C		56C	56C	18	25	1.7			

Commercial Water

Technical Data - Pump Hydraulics / Motor Sizing

3SV 2900 RPM

No. of Impellers	Maximum HP draw	Motor Selection using SF			Motor Selection 1.0 SF			Shutoff TDH (Meters)	Shutoff TDH (psi)	Shutoff TDH (Bar)	Casing/Sleeve Pressure Rating (standard assy.)	Pump Flange Rating
		Rated HP	NEMA Motor Frame		Rated HP	NEMA Motor Frame						
			ODP	TEFC		ODP	TEFC					
30	3.30	3.00	184TC	184TC	5.00	213TC	213TC	227	322	22.2	25 Bar (362 psi)	Class 250 / 300
29	3.15		184TC	184TC		213TC	213TC	212	301	20.7		
28	3.05		184TC	184TC		213TC	213TC	204	290	20.0		
27	2.94		184TC	184TC		184TC	184TC	197	280	19.3		
26	2.83		184TC	184TC		184TC	184TC	190	270	18.6		
25	2.73		184TC	184TC	3.00	184TC	184TC	183	260	17.9		
24	2.62		184TC	184TC		184TC	184TC	175	249	17.2		
23	2.51		184TC	184TC		184TC	184TC	168	238	16.4		
22	2.40		184TC	184TC		184TC	184TC	160	228	15.7		
21	2.29		2.00	56C		56C	184TC	184TC	153	218		
20	2.19	56C		56C	184TC	184TC	146	207	14.3			
19	2.08	56C		56C	184TC	184TC	139	197	13.6			
18	1.97	56C		56C	2.00	56C	56C	131	186	12.8		
17	1.86	56C		56C		56C	56C	124	176	12.1		
16	1.76	56C		56C		56C	56C	116	165	11.4		
15	1.65	1.50		56C	56C	56C	56C	109	154	10.7		
14	1.54		56C	56C	56C	56C	102	145	10.0			
13	1.43		56C	56C	1.50	56C	56C	95	134	9.3		
12	1.35		56C	56C		56C	56C	87	123	8.5		
11	1.24		56C	56C		56C	56C	80	114	7.8		
10	1.13		1.00	56C	56C	56C	56C	73	103	7.1		
9	1.02	56C		56C	56C	56C	66	93	6.4			
8	0.91	56C		56C	1.00	56C	56C	58	82	5.7		
7	0.80	56C	56C	56C		56C	51	72	5.0			
6	0.68	0.75	56C	56C	0.75	56C	56C	44	62	4.3		
5	0.57		56C	56C		56C	56C	36	52	3.6		
4	0.47	0.50	56C	56C	0.50	56C	56C	29	41	2.9		
3	0.36		56C	56C		56C	56C	22	31	2.1		

Commercial Water

Technical Data - Pump Hydraulics / Motor Sizing

5SV 2900 RPM

No. of Impellers	Maximum HP draw	Motor Selection using SF				Motor Selection 1.0 SF			Shutoff TDH (Meters)	Shutoff TDH (psi)	Shutoff TDH (Bar)	Casing/Sleeve Pressure Rating (standard assy.)	Pump Flange Rating
		Rated HP	NEMA Motor Frame		Rated HP	NEMA Motor Frame							
			ODP	TEFC		ODP	TEFC						
27	5.26	5.00	213TC	213TC	7.50	215TC	215TC	204	290	20.0	25 Bar (362 psi)	Class 250 / 300	
26	5.07		213TC	213TC		215TC	215TC	196	279	19.2			
25	4.83		213TC	213TC		5.00	213TC	213TC	180	256			17.6
24	4.65		213TC	213TC			213TC	213TC	173	245			16.9
23	4.46		213TC	213TC			213TC	213TC	166	235			16.2
22	4.28		213TC	213TC	213TC		213TC	158	225	15.5			
21	4.09		213TC	213TC	213TC		213TC	151	215	14.8			
20	3.91		213TC	213TC	3.00	213TC	213TC	144	204	14.1			
19	3.73		213TC	213TC		213TC	213TC	137	194	13.4			
18	3.54		213TC	213TC		213TC	213TC	130	184	12.7			
17	3.36	3.00	184TC	184TC		213TC	213TC	122	174	12.0			
16	3.17		184TC	184TC		213TC	213TC	115	164	11.3			
15	2.99		184TC	184TC	2.00	184TC	184TC	108	153	10.6			
14	2.81		184TC	184TC		184TC	184TC	101	143	9.9			
13	2.63		184TC	184TC		184TC	184TC	94	133	9.2			
12	2.44	184TC	184TC	184TC		184TC	86	123	8.5				
11	2.27	2.00	56C	56C		184TC	184TC	80	113	7.8			
10	2.08		56C	56C	184TC	184TC	72	103	7.1				
9	1.90		56C	56C	1.50	56C	56C	65	92	6.4			
8	1.71	1.50	56C	56C		56C	56C	58	82	5.7			
7	1.53		56C	56C		56C	56C	51	72	4.9			
6	1.35		56C	56C	1.00	56C	56C	43	61	4.2			
5	1.19	1.00	56C	56C		56C	56C	36	52	3.6			
4	1.00		56C	56C		56C	56C	29	41	2.8			
3	0.80	0.75	56C	56C	1.00	56C	56C	22	31	2.1			

10SV 2900 RPM

No. of Impellers	Maximum HP draw	Motor Selection using SF				Motor Selection 1.0 SF			Shutoff TDH (Meters)	Shutoff TDH (psi)	Shutoff TDH (Bar)	Casing/Sleeve Pressure Rating (standard assy.)	Pump Flange Rating
		Rated HP	NEMA Motor Frame		Rated HP	NEMA Motor Frame							
			ODP	TEFC		ODP	TEFC						
20	9.78	10.00	215TC	254TC	10.00	215TC	254TC	228	324	22.4	25 Bar (362 psi)	Class 250 / 300	
19	9.30		215TC	254TC		215TC	254TC	217	308	21.2			
18	8.83		215TC	254TC		7.50	215TC	254TC	206	292			20.1
17	8.35	215TC	215TC	215TC	254TC		194	276	19.0				
16	7.87	215TC	215TC	215TC	254TC		183	259	17.9				
15	7.41	7.50	215TC	215TC	5.00		215TC	215TC	171	243			16.8
14	6.93		215TC	215TC			215TC	215TC	160	227			15.7
13	6.45		215TC	215TC		215TC	215TC	149	211	14.5			
12	5.98	5.00	215TC	215TC	3.00	215TC	215TC	137	195	13.4			
11	5.40		213TC	213TC		215TC	215TC	123	175	12.1			
10	4.94		213TC	213TC		213TC	213TC	112	159	11.0			
9	4.47		213TC	213TC		213TC	213TC	101	143	9.9			
8	3.97		213TC	213TC		1.50	213TC	213TC	91	129			8.9
7	3.50	3.00	184TC	184TC	213TC		213TC	80	113	7.8			
6	3.10		184TC	184TC	213TC		213TC	68	97	6.7			
5	2.62		184TC	184TC	184TC	184TC	57	81	5.6				
4	2.12	2.00	56C	56C	2.00	184TC	184TC	46	65	4.5			
3	1.68	1.50	56C	56C	1.50	56C	56C	34	49	3.3			
2	1.20		56C	56C		56C	56C	23	32	2.2			

Commercial Water

Technical Data - Pump Hydraulics / Motor Sizing

15SV 2900 RPM

No. of Impellers	Maximum HP draw	Motor Selection using SF				Motor Selection 1.0 SF				Shutoff TDH (Meters)	Shutoff TDH (psi)	Shutoff TDH (Bar)	Casing/Sleeve Pressure Rating (standard assy.)	Pump Flange Rating
		Rated HP	NEMA Motor Frame		Rated HP	NEMA Motor Frame								
			ODP	TEFC		ODP	TEFC							
15	16.36	15.00	254TC	256TC	20.00	254TC	284TC	210	298	20.5	25 Bar (362 psi)	Class 250 / 300		
14	15.36		254TC	256TC		254TC	284TC	196	278	19.2				
13	14.34		254TC	256TC		15.00	254TC	256TC	182	258			17.8	
12	13.33		254TC	256TC			254TC	256TC	168	238			16.4	
11	12.33	254TC	256TC	254TC	256TC		154	218	15.1					
10	11.32	10.00	215TC	254TC	10.00	254TC	256TC	140	198	13.7				
9	10.47		215TC	254TC		254TC	256TC	125	178	12.3				
8	9.45	7.50	215TC	254TC	7.50	215TC	254TC	111	158	10.9				
7	8.41		215TC	215TC		215TC	254TC	98	139	9.6				
6	7.39		215TC	215TC		215TC	215TC	84	119	8.2				
5	6.12	5.00	215TC	215TC	5.00	215TC	215TC	69	98	6.8				
4	5.15		213TC	213TC		215TC	215TC	55	79	5.4				
3	4.23		213TC	213TC		213TC	213TC	41	59	4.0				
2	3.26	3.00	184TC	184TC	5.00	213TC	213TC	27	39	2.7				

22SV 2900 RPM

No. of Impellers	Maximum HP draw	Motor Selection using SF				Motor Selection 1.0 SF				Shutoff TDH (Meters)	Shutoff TDH (psi)	Shutoff TDH (Bar)	Casing/Sleeve Pressure Rating (standard assy.)	Pump Flange Rating
		Rated HP	NEMA Motor Frame		Rated HP	NEMA Motor Frame								
			ODP	TEFC		ODP	TEFC							
12	16.93	15.00	254TC	256TC	20.00	254TC	284TC	176	249	17.2	25 Bar (362 psi)	Class 250 / 300		
11	15.62		254TC	256TC		254TC	284TC	161	228	15.8				
10	14.52		254TC	256TC		15.00	254TC	256TC	147	209			14.4	
9	13.18		254TC	256TC			254TC	256TC	132	188			13.0	
8	11.85	254TC	256TC	254TC	256TC		118	167	11.5					
7	10.51	10.00	215TC	254TC	10.00	254TC	256TC	103	146	10.1				
6	9.17		215TC	254TC		215TC	254TC	88	125	8.6				
5	7.69	7.50	215TC	215TC	7.50	215TC	254TC	72	103	7.1				
4	6.38		215TC	215TC		215TC	215TC	58	82	5.7				
3	5.07	5.00	213TC	213TC	5.00	215TC	215TC	43	62	4.3				
2	3.76		213TC	213TC		213TC	213TC	29	41	2.8				

Technical Data - Pump Hydraulics / Motor Sizing

33SV 2900 RPM

No. of Impellers	Maximum HP draw	Motor Selection using SF			Motor Selection 1.0 SF			Shutoff TDH (Meters)	Shutoff TDH (Feet)	Shutoff TDH (psi)	Shutoff TDH (Bar)	Casing/Sleeve Pressure Rating (standard assy.)	Pump Flange Rating	Stages Requiring Thrust Balancing Piston
		Rated HP	NEMA Motor Frame		Rated HP	NEMA Motor Frame								
			ODP	TEFC		ODP	TEFC							
10	32.6	30	286TC	286TC	40	324TSC	326TSC	229	752	326	22.4	25 Bar (362 psi)	Class 250 / 300	Thrust Piston Required
10/1	31.9							223	733	317	21.9			
10/2	31.1							217	713	309	21.3			
9	29.4	25	284TC	286TC	30	286TC	206	677	293	20.2				
9/1	28.7						201	658	285	19.6				
9/2	27.9						195	638	276	19.0				
8	26.2	20	254TC	284TC	25	284TC	286TC	184	602	261	18.0			
8/1	25.5							178	583	252	17.4			
8/2	24.7							172	563	244	16.8			
7	23.0	15	254TC	256TC	15	254TC	256TC	161	527	228	15.7			
7/1	22.3							155	508	220	15.2			
7/2	21.6							149	488	211	14.6			
6	19.9	10	215TC	254TC	10	215TC	254TC	138	452	196	13.5			
6/1	19.1							132	432	187	12.9			
6/2	18.4							126	413	179	12.3			
5	16.7	7.5	213TC	215TC	7.5	213TC	215TC	115	377	163	11.2			
5/1	15.9							109	357	155	10.7			
5/2	15.2							103	338	146	10.1			
4	13.5	7.5	213TC	215TC	7.5	213TC	215TC	92	302	131	9.0			
4/1	12.7							86	282	122	8.4			
4/2	12.0							80	263	114	7.8			
3	10.3	7.5	213TC	215TC	7.5	213TC	215TC	69	227	98	6.8			
3/1	9.6							63	207	90	6.2			
3/2	8.8							57	188	81	5.6			
2	7.1	7.5	213TC	215TC	7.5	213TC	215TC	46	151	65	4.5			
2/1	6.4							40	132	57	3.9			

Commercial Water

Technical Data - Pump Hydraulics / Motor Sizing

46SV 2900 RPM

No. of Impellers	Maximum HP draw	Motor Selection using SF			Motor Selection 1.0 SF			Shutoff TDH (Meters)	Shutoff TDH (Feet)	Shutoff TDH (psi)	Shutoff TDH (Bar)	Casing/Sleeve Pressure Rating (standard assy.)	Pump Flange Rating	Stages Requiring Thrust Balancing Piston						
		Rated HP	NEMA Motor Frame		Rated HP	NEMA Motor Frame														
			ODP	TEFC		ODP	TEFC													
10/2	45.3	40.00	324TSC	326TSC	50	365TSC	365TSC	244	800	346	23.9	25 Bar (362 psi)	Class 250 / 300	Thrust Piston Required						
9	42.8							229	752	326	22.4									
9/1	41.8							224	734	318	21.9									
9/2	40.7							218	716	310	21.4									
8	38.2							40	324TSC	326TSC	40				324TSC	326TSC	204	668	289	19.9
8/1	37.1																198	650	282	19.4
8/2	36.1	193	632	274	18.9															
7	33.6	30	286TC	286TC	40	324TSC	326TSC						178				584	253	17.4	
7/1	32.5												173				566	245	16.9	
7/2	31.5												167				547	237	16.3	
6	29.0							25	284TC	286TC	30		286TC		286TC	152	500	217	14.9	
6/1	27.9															147	482	209	14.4	
6/2	26.9															141	463	201	13.8	
5	24.3	20	254TC	284TC	25	284TC	286TC									127	416	180	12.4	
5/1	23.3															121	398	172	11.9	
5/2	22.3															116	379	164	11.3	
4	19.7							15	254TC	256TC	20		254TC		284TC	101	332	144	9.9	
4/1	18.7															95	313	136	9.3	
4/2	17.7											90		295		128	8.8			
3	15.1	10	215TC	254TC	15	254TC	256TC					76		248		107	7.4			
3/1	14.1											70		229		99	6.8			
3/2	13.1											64		211		91	6.3			
2	10.5							50	164	71	4.9									
2/1	9.5							10	215TC	254TC	10	215TC	254TC	44	145	63	4.3			

66SV 2900 RPM

No. of Impellers	Maximum HP draw	Motor Selection using SF			Motor Selection 1.0 SF			Shutoff TDH (Meters)	Shutoff TDH (Feet)	Shutoff TDH (psi)	Shutoff TDH (Bar)	Casing/Sleeve Pressure Rating (standard assy.)	Pump Flange Rating	Stages Requiring Thrust Balancing Piston					
		Rated HP	NEMA Motor Frame		Rated HP	NEMA Motor Frame													
			ODP	TEFC		ODP	TEFC												
6	42.3	40	324TSC	326TSC	50	365TSC	365TSC	172	565	245	16.9	25 Bar (362 psi)	Class 250 / 300	Thrust Piston Required					
6/1	40.2							167	547	237	16.3								
6/2	38.2							161	528	229	15.8								
5	35.1	30	286TC	286TC	40	324TSC	326TSC	144	471	204	14.1								
5/1	33.1							138	452	196	13.5								
5/2	31.0							132	433	188	12.9								
4	27.9	25	284TC	286TC	30	286TC	286TC	115	376	163	11.2								
4/1	25.9							109	358	155	10.7								
4/2	23.8							103	339	147	10.1								
3	20.8	20	254TC	284TC	25	284TC	286TC	86	282	122	8.4								
3/1	18.7							80	263	114	7.8								
3/2	16.7							74	244	106	7.3								
2	13.6	15	254TC	256TC	20	254TC	284TC	57	188	81	5.6								
2/1	11.5							15	254TC	256TC	15		254TC		256TC	52	169	73	5.0

Xylem |'zīləm|

- 1) The tissue in plants that brings water upward from the roots;
- 2) a leading global water technology company.

We're a global team unified in a common purpose: creating advanced technology solutions to the world's water challenges. Developing new technologies that will improve the way water is used, conserved, and re-used in the future is central to our work. Our products and services move, treat, analyze, monitor and return water to the environment, in public utility, industrial, residential and commercial building services settings. Xylem also provides a leading portfolio of smart metering, network technologies and advanced analytics solutions for water, electric and gas utilities. In more than 150 countries, we have strong, long-standing relationships with customers who know us for our powerful combination of leading product brands and applications expertise with a strong focus on developing comprehensive, sustainable solutions.

For more information on how Xylem can help you, go to www.xylem.com



Xylem Inc.
1 Goulds Drive
Auburn, NY 13021
Phone: (866) 673-0428
Fax: (888) 322-5877
www.xylem.com/goulds

Goulds is a registered trademark of Goulds Pumps, Inc. and is used under license.
© 2019 Xylem Inc. CeSV5060 R4 December 2019