



Elevator Sump Pump Kits

OIL SMART - Staying dry and protecting the environment



The Oil Smart kits consist of panel, oil smart switch, liquid smart alarm sensor and pump. The setup allows water to be pumped from elevator sumps and transformer vaults without danger of pumping oil into sewers and waterways.

FEATURES

- Protects environment from hazardous waste
- The solid state device senses between oil and water
- Only operates pump if water is sensed by probes.
Does not operate if oil is sensed by probes.

FEATURES FOR PUMP

- Effluent, 1/3, 1/2, 3/4 and 1 HP, single phase pump
- Hard faced seal
- Cast iron construction
- Effluent, 1/2, 3/4 and 1 HP, three phase pump

ELEVATOR PUMP KITS

Brands	Model Number	Electrical	Panel	Oil Smart Switch	Liquid Smart Sensor	Pump
B&G	ELKT2EC0311L	1/3 HP 1/60/115	A1SEE1	Included	Included	2EC0311L
	ELKT2EC0511	1/2 HP 1/60/115				2EC0511
	ELKT2EC0512	1/2 HP 1/60/230				2EC0512
	ELKT2EC0712	3/4 HP 1/60/230				2EC0712
	ELKT2EC1012	1 HP 1/60/230				2EC1012
	ELKT2EC0538	1/2 HP 3/60/200	A3SEE14063			2EC0538
	ELKT2EC0532	1/2 HP 3/60/230	A3SEE12540			2EC0532
	ELKT2EC0534	1/2 HP 3/60/460	A3SEE11625			2EC0534
	ELKT2EC0738	3/4 HP 3/60/200	A3SEE16010			2EC0738
	ELKT2EC0732	3/4 HP 3/60/230	A3SEE14063			2EC0732
	ELKT2EC0734	3/4 HP 3/60/460	A3SEE12540			2EC0734
	ELKT2EC1038	1 HP 3/60/200	A3SEE16010			2EC1038
	ELKT2EC1032	1 HP 3/60/230	A3SEE16010			2EC1032
	ELKT2EC1034	1 HP 3/60/460	A3SEE14063			2EC1034

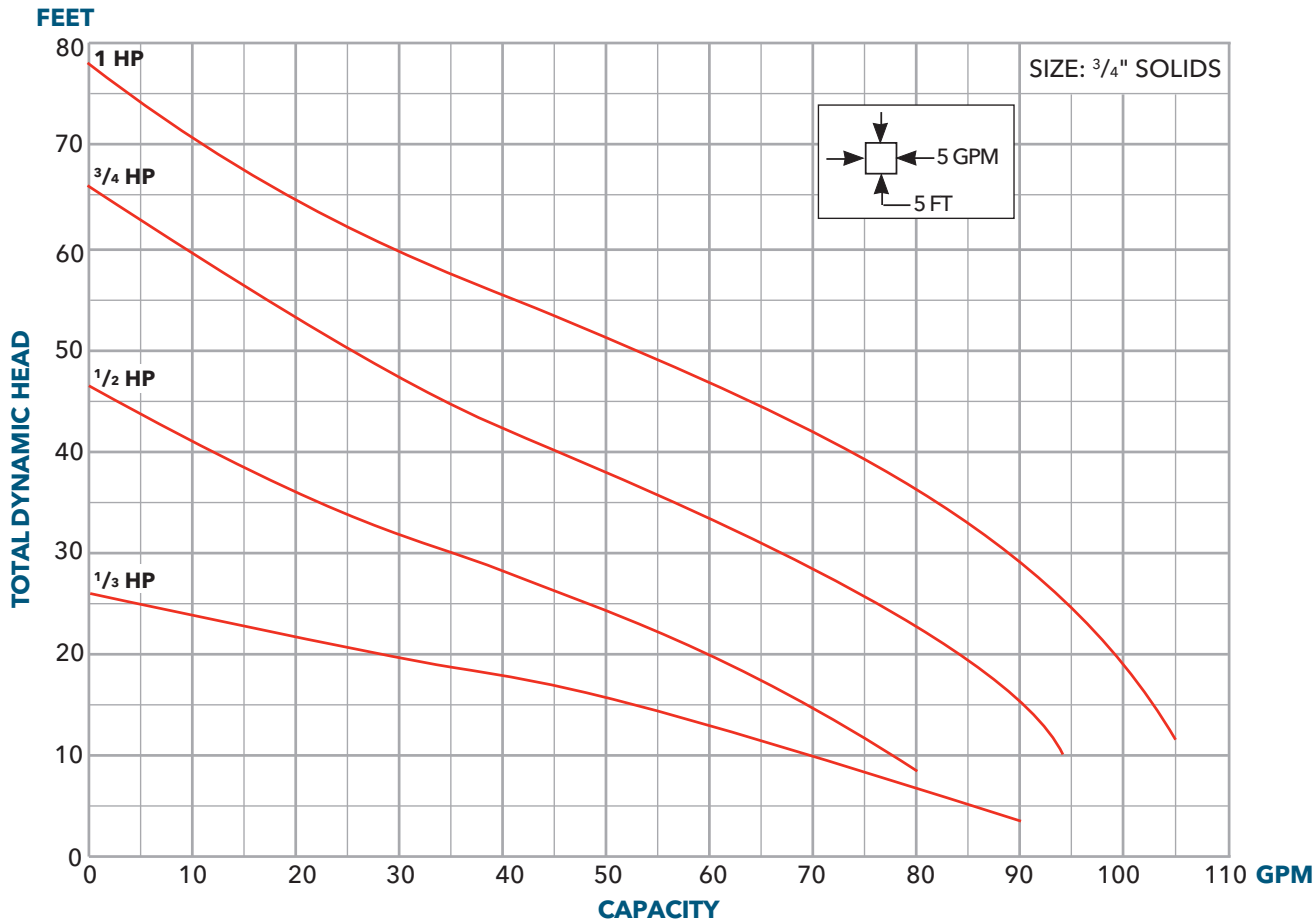

PANEL LAYOUTS

SIMPLEX SINGLE PHASE PANEL – A1SEE1

Enclosure Dimensions (in inches)

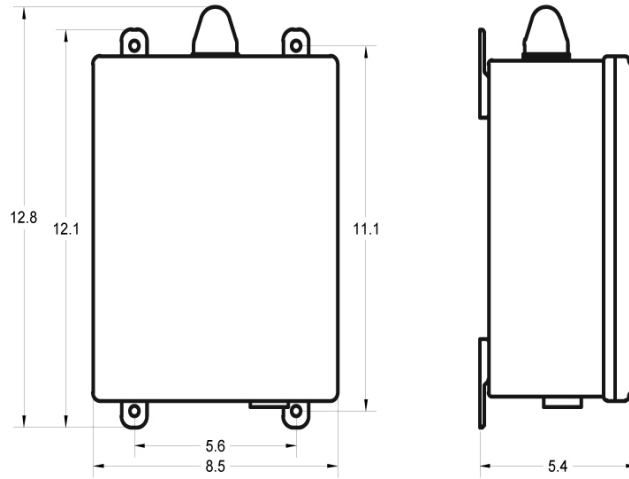

Wiring Diagram

INSIDE VIEW

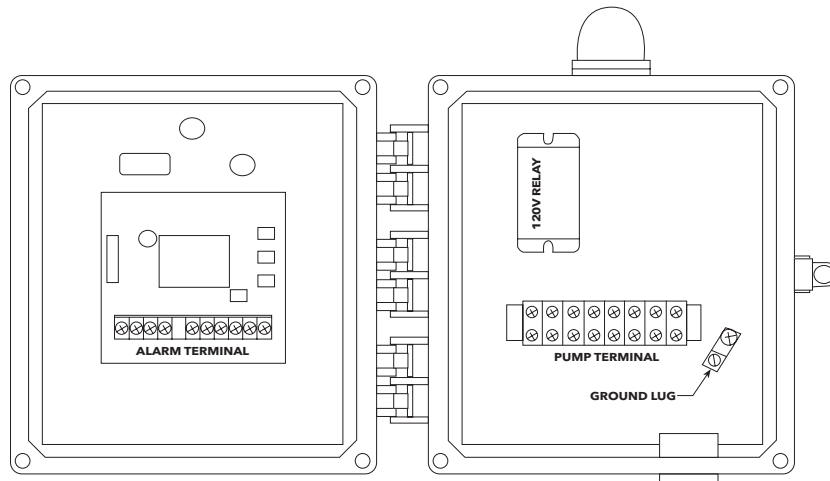

ALARM TERMINAL

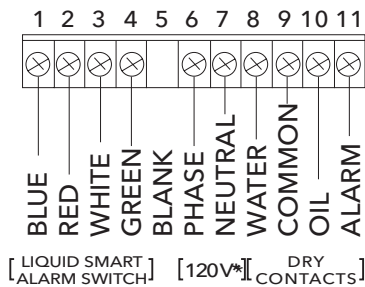

* Hook up separate 120V supply here or jump from pump terminal 1 and 3 to alarm terminal 6 and 7 for power.

PUMP TERMINAL

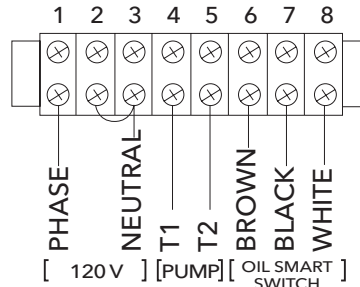

* For 240V, remove jumper and supply power to terminals 1 and 2, with neutral on 3.

PANEL LAYOUTS

SIMPLEX THREE PHASE PANEL – A3SEE1

Enclosure Dimensions (in inches)

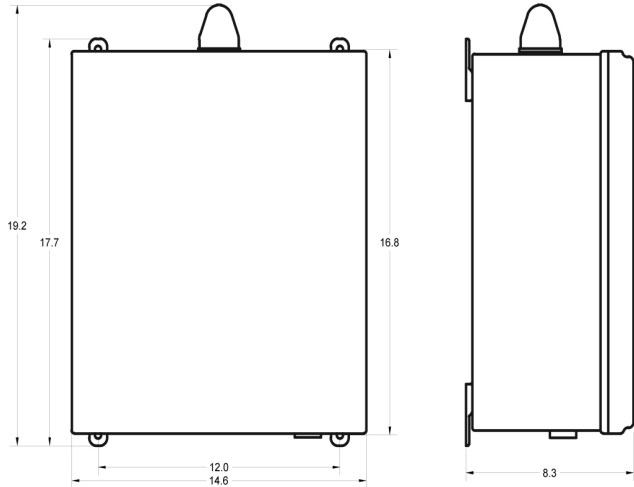

Wiring Diagram

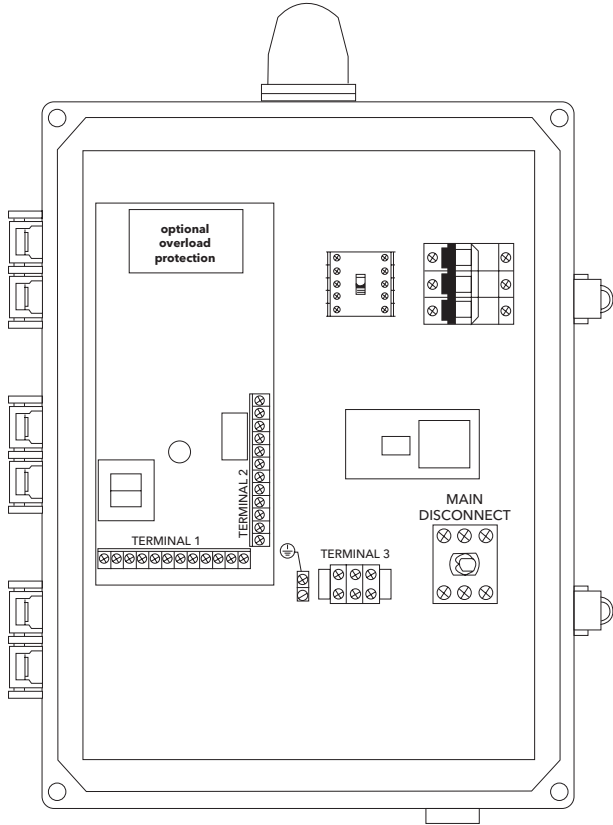

Wiring Diagram

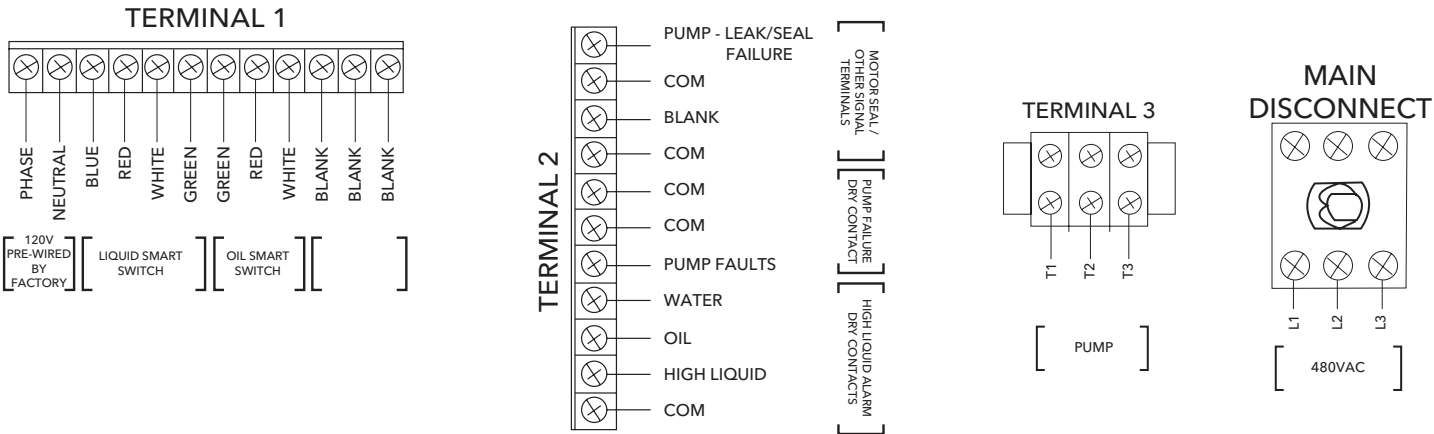

Xylem Inc.
 2881 East Bayard Street Ext., Suite A
 Seneca Falls, NY 13148
 Phone: (866) 325-4210
 Fax: (888) 322-5877
www.bellgossett.com