

## GENERAL INFORMATION, INSTALLATION AND OPERATION SPECIFICATIONS

### 1.0 GENERAL REQUIREMENTS

- 1.1 Provide and install BoilerMagXT in accordance with manual specifications
- 1.2 All work is to be performed in neat workmanship like manner compliant with all local code authorities
- 1.3 BoilerMagXT is to be used in large properties where build-up of ferrous oxide and scale in central heating systems is prevalent

### 2.0 PRODUCT DATA

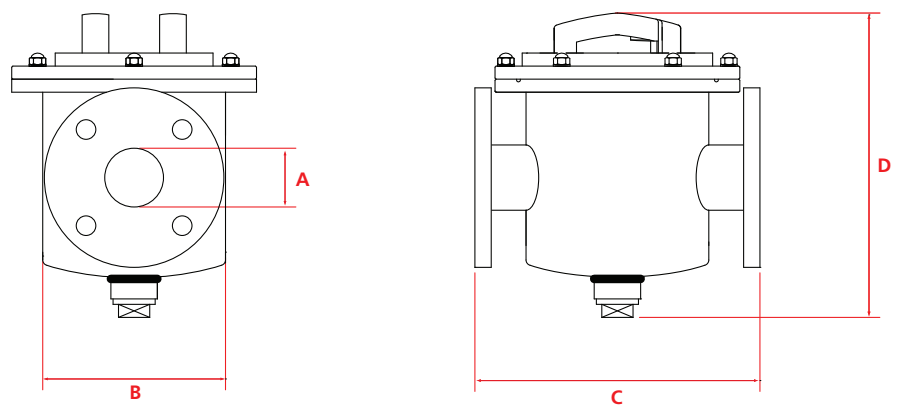

Item Code	Part No.	Inlet / Outlet Dia. A	Filter Dia. B	Flange spacing C	Height D	No. magnetic rods	**Flow rate gallons/minute (m <sup>3</sup> /hour)	Weight lbs/kgs
BMXT/1.5	BMXT100/ANSI	1.5" / 38mm	4" / 100mm	10" / 250mm	11" / 280mm	3	40 (9)	20 / 9
BMXT/2	BMXT150/ANSI	2" / 50mm	6 3/4" / 170mm	11 1/8" / 280mm	11" / 280mm	5	79 (18)	42 / 19
BMXT/3	BMXT200/3/ANSI	3" / 75mm	8 5/8" / 220mm	14 1/8" / 360mm	13 1/4" / 335mm	7	229 (52)	82 / 37
BMXT/4	BMXT200/ANSI	4" / 100mm	8 5/8" / 220mm	14 7/8" / 380mm	13 1/4" / 335mm	7	308 (70)	82 / 37
BMXT/6	BMXT300HF/ANSI	6" / 150mm	12 3/4" / 325mm	19 1/4" / 490mm	16 1/2" / 420mm	9	440 (100)	133 / 60
BMXT/8	BMXT300HF/8/ANSI	8" / 200mm	12 3/4" / 325mm	20 5/8" / 525mm	18 1/8" / 460mm	9	950 (215)	140 / 64
BMXT/10*	BMXT400/10/ANSI*	10" / 250mm	16" / 406mm	30" / 760mm	29 3/4" / 754mm	16	968 (220)	190 / 86
BMXT/12*	BMXT400/12/ANSI*	12" / 300mm	16" / 406mm	30" / 760mm	29 3/4" / 754mm	16	1364 (310)	195 / 88

\* Made to order sizes  
\*\* Based on flow velocity of 6-8 ft/sec.

### PERFORMANCE

<b>Magnetic performance</b>	9,000 Gauss high strength
<b>Performance reading</b>	On tube surface
<b>Magnetic material</b>	Rare Earth Neodymium Iron Boron N42SH
<b>Temperature</b>	41° to 302°F / 5° to 150°C (212°F / 110°C if using automatic air vent)
<b>Operating pressure</b>	+/- 174psi / 12 bar (145psi / 10 bar if using automatic air vent)
<b>Drain valve</b>	3/4" NPT BMXT/1.5 (BMXT100/ANSI), all others 1 1/4" NPT

### MATERIALS/CONSTRUCTION

<b>Housing</b>	304 grade stainless steel
<b>Tube cartridge</b>	316 grade stainless steel – aerospace quality
<b>Other parts</b>	304 grade stainless steel
<b>Surface finish</b>	Internal - bead blast External - powder coated, black
<b>Sealing</b>	Viton o-ring, brown

### INCLUDES

Additional Automatic Air Vent that has been packaged along with unit separately. The auto-vent will automatically release the trapped air maintaining heating efficiency

### OPTIONS

High temperature Samarium Cobalt magnetic material +482°F / 250°C

### WARRANTY

Industry leading 10 years

\*\*\*GAUSS: The gauss is the unit of measurement of magnetic flux density

### 3.0 INSTALLATION

- 3.1 BoilerMagXT is typically installed on the return circuit as close to the boiler as possible. On larger systems, units may be installed elsewhere to give extra protection for radiators and pipework
- 3.2 BoilerMagXT should be located in a position which gives it adequate access above to lift out the magnets during service and maintenance
- 3.3 Access is also required to the underneath of the unit to connect a hose or hold a bucket during draining
- 3.4 Isolation valves (not supplied) should be installed for cleaning and servicing to be carried out

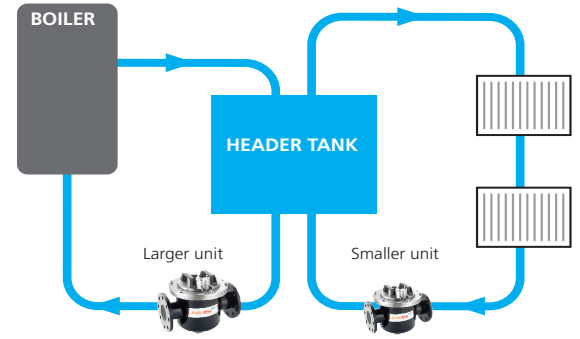

### 4.0 PRESSURE DROP DATA

2" BMXT	
Flow (gpm)	Pressure Differential (psi)
0	0.00
22	0.04
44	0.16
66	0.36
88	0.63

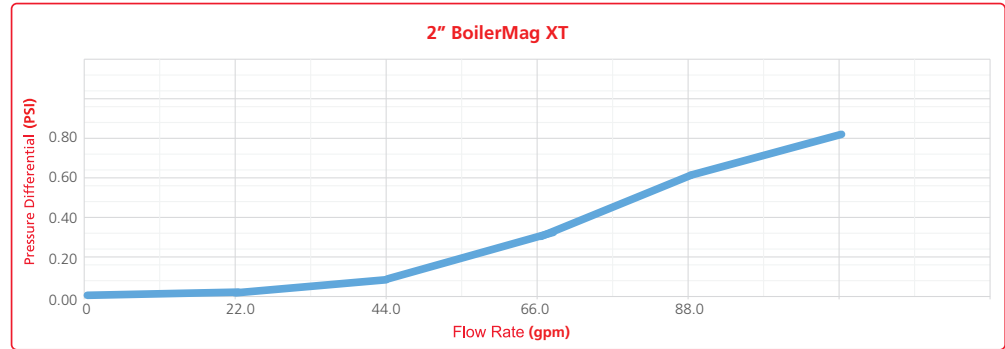

4" BMXT	
Flow (gpm)	Pressure Differential (psi)
0	0.00
22	0.00
44	0.01
66	0.02
88	0.03
110	0.05
220	0.21
242	0.26
308	0.42

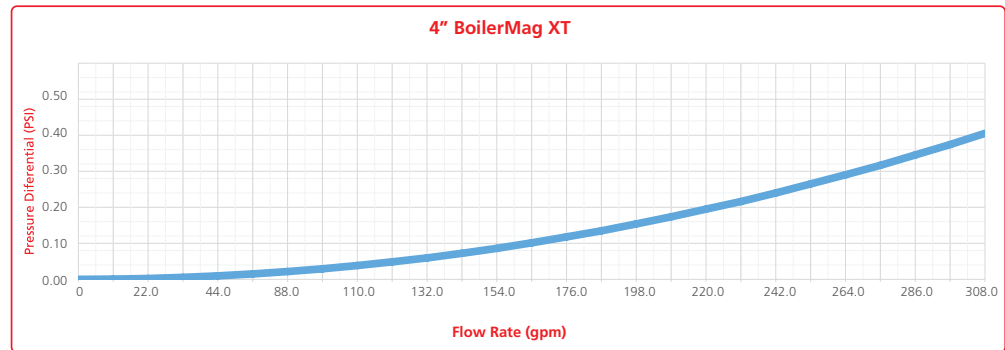

6" BMXT	
Flow (gpm)	Pressure Differential (psi)
0	0.00
22	0.00
44	0.00
66	0.00
88	0.00
110	0.01
220	0.02
242	0.03
308	0.05
374	0.07
440	0.09

