

BOILER BUDDY®

buffer tank

Your Boiler's Best Friend

The Boiler Buddy buffer tank is designed to be used in heating systems with **low-mass boilers**, **geothermal**, **chilled water applications**, or **low-mass radiation**. Heating units operating at low loads will cause the compressor to short cycle. This condition promotes inefficiency and accelerates the life expectancy of the components most often resulting in nuisance service calls.

The Boiler Buddy tank is a factory insulated and jacketed storage tank, adding mass to the system and providing the necessary buffer to prevent short cycling.

The Boiler Buddy models BB-50-G, BB-80-3W, and BB-119-3W now come standard with three aquastat wells for precision temperature measurement.

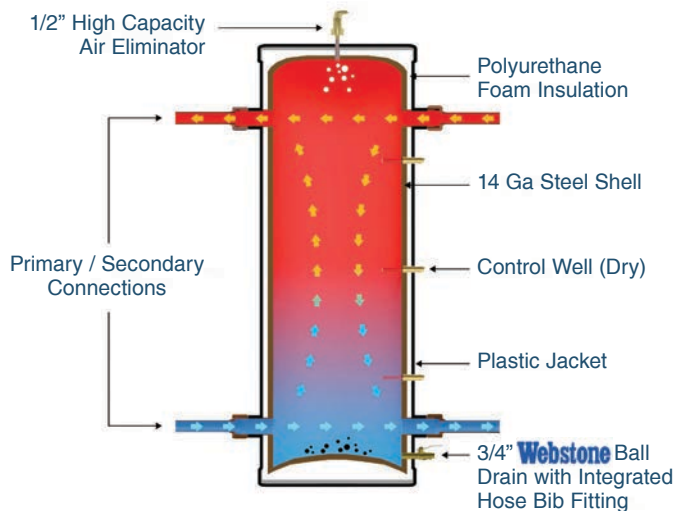

MODELS:

BB-18 BB-30

1 aquastat well

BB-50-G BB-80-3W BB-119-3W

3 aquastat wells

BB-80-C

Includes a carbon steel internal coil and 1 aquastat well.

***Boiler Buddy tanks are not for use with potable water.**



Engineered with your needs in mind:

- Aquastat Control Well(s) included for precise temperature measurement for heating and geothermal systems.
- Air Eliminator built into the top of tank provides optimal air elimination for the whole system.
- Boiler Buddy provides hydraulic separation, making piping layout simple.
- Webstone ball drain allows easy and reliable sediment removal and also works exceptionally well for fast filling the system.
- Designed with large nipples to provide better flow that is easier on equipment, more efficient, and allows for better mixing in tank.



Corporate Office & Warehouse
7500 N. 81st Street
Milwaukee, WI 53223

877 377 0011
www.BoilerBuddy.com

A division of:
HOT WATER
PRODUCTS

Examples of Common Installations

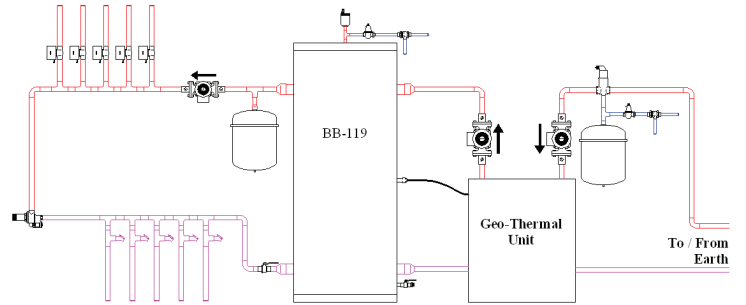
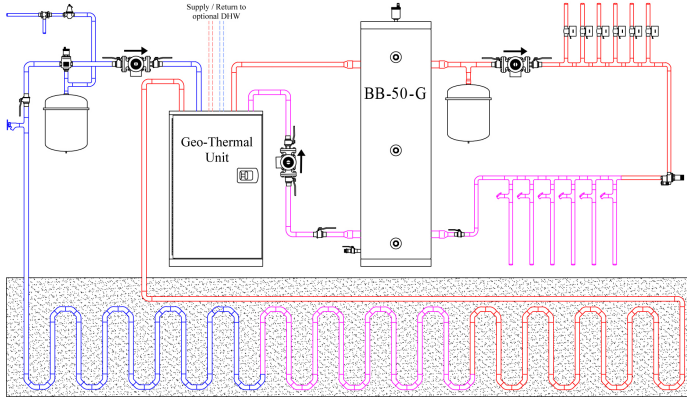
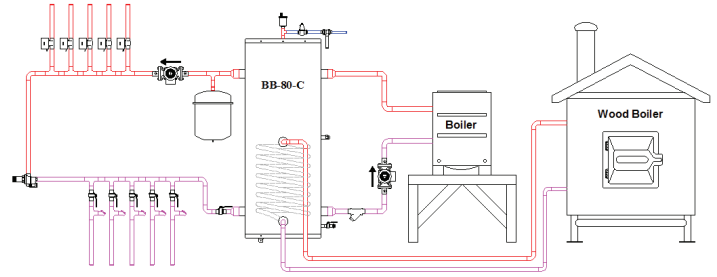
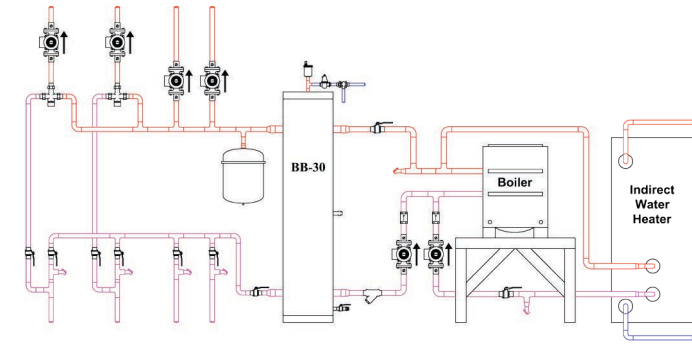

Dimensions

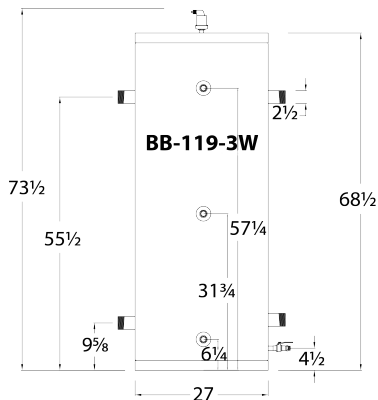
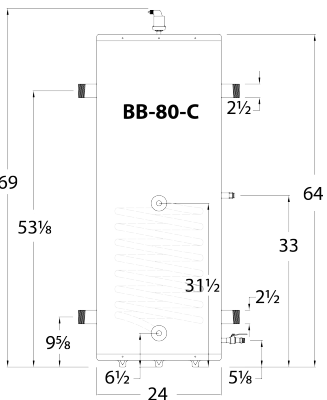
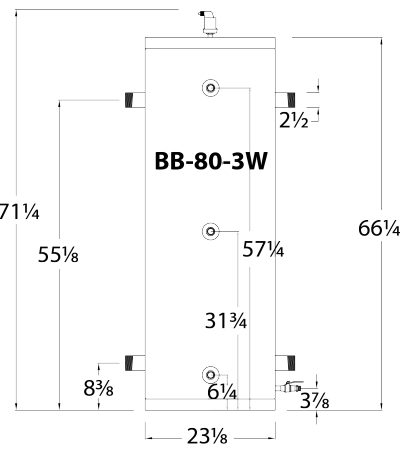
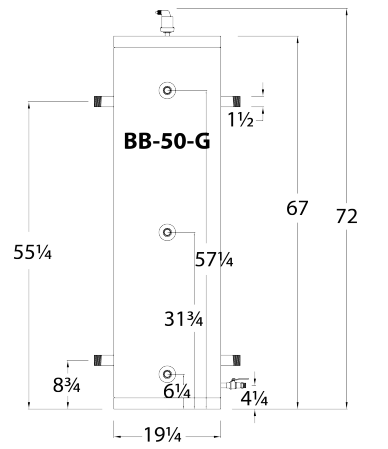
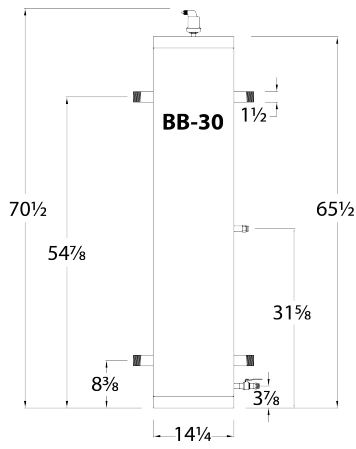
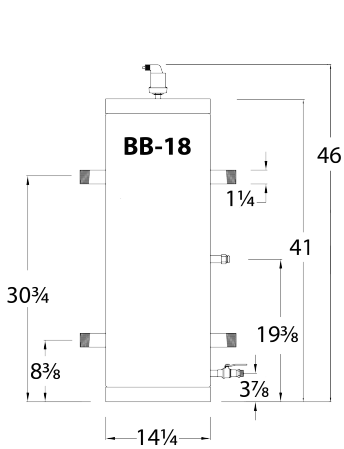

Model	Height	Diameter	Capacity Gallons	Max Pressure PSI
BB-18	46"	14-1/4"	18	75
BB-30	70-1/2"	14-1/4"	30	75
BB-50-G	72"	19-1/4"	50	75
BB-80-3W	71-1/4"	23-1/8"	80	75
BB-119-3W	73-1/2"	27"	119	75
BB-80-C	69"	24"	80	75

Model	Primary/Secondary Connections NPT Male	Drain Connections NH(M)	Air Vent	Shipping Weight
BB-18	1-1/4"	3/4"	1/2"	55
BB-30	1-1/2"	3/4"	1/2"	83
BB-50-G	1-1/2"	3/4"	1/2"	115
BB-80-3W	2-1/2"	3/4"	1/2"	128
BB-119-3W	2-1/2"	3/4"	1/2"	217
BB-80-C	2-1/2"	3/4"	1/2"	153

Boiler Buddy® includes the following components:

- Premium high capacity air eliminator
- All necessary nipples
- Premium full port boiler drain
- Brass hose bushing
- Brass aquastat well (dry)

WARNING:
This unit is NOT suitable for non-oxygen barrier tubing.
Do not use with potable water.

