



Series 60 In-Line Mounted Centrifugal Pump

MAINTENANCE-FREE • HEADER PUMP APPLICATIONS

B-102A

 **Bell & Gossett**
a xylem brand

Series 60 In-Line Mounted Centrifugal Pump

Description

A maintenance-free, in-line, cast iron centrifugal pump for header pump applications.

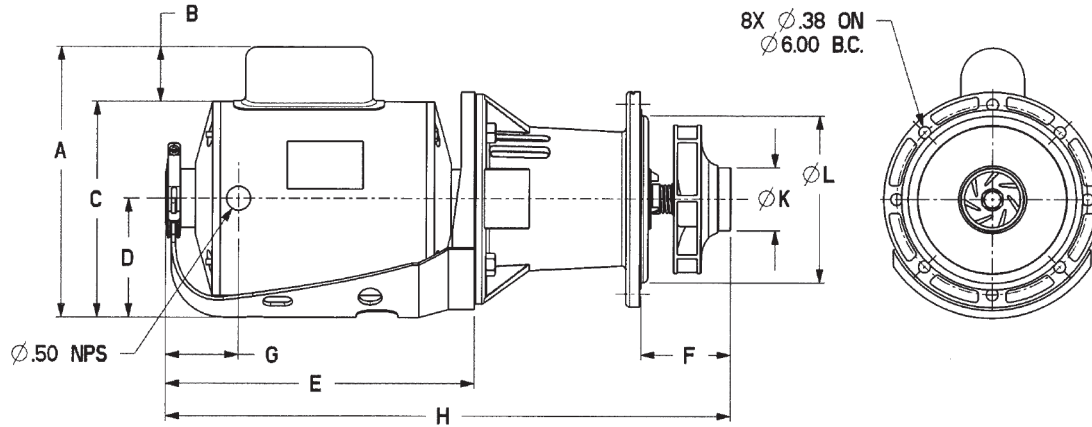

Mtr HP	A	B	C	D	E	F	G	H	K	L
1/3 HP	8.56	2.25	6.81	3.75	8.8	2.88	1.88	14	1.99	5.28
1/2 HP	8.56	2.25	6.81	3.75	9.8	2.88	1.88	15	1.99	5.28
3/4 HP	8.56	2.25	6.81	3.75	9.8	2.88	1.88	15	1.99	5.28

Product Features

- Maintenance-free pump
- Internally self-flushing mechanical seal
- XLII® lubrication system
- Three-year warranty*
- Factory test
- ISO 9001 certified
- EPDM coupling

Volts _____, Encl. _____

Special _____

Specifications

_____ GMP _____ FT.

Performance Characteristic Curve

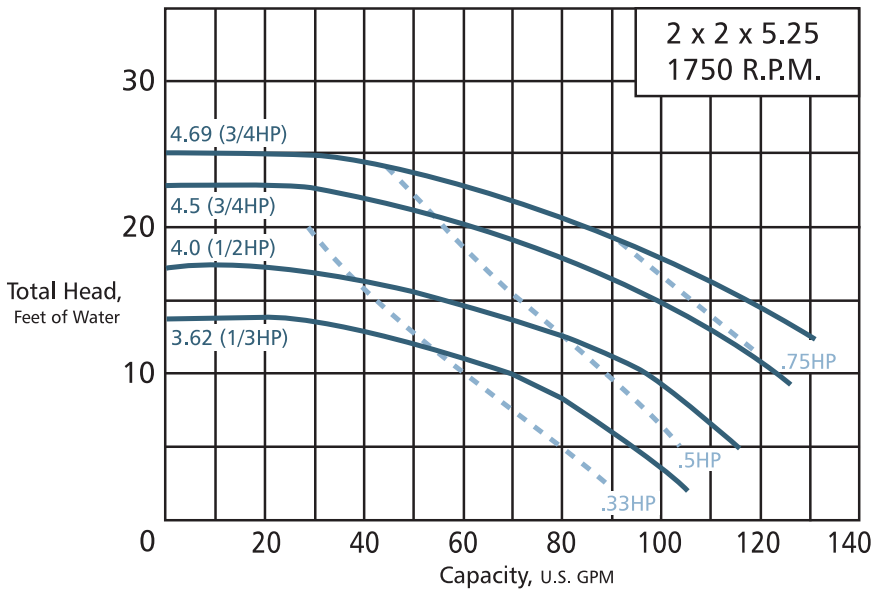

Materials of Construction

ImpellerCast Bronze
 ShaftAlloy Steel
 Shaft SleeveCopper Alloy
 BracketCast Iron with
 Stainless Steel
 Face Plate
 Mechanical SealBuna/Carbon -
 Ceramic
 (Standard) (-20°F to 225°F)

Operating Data

Maximum working pressure175 psi
 Operating temperature225°F

* Materials and workmanship only.



Xylem Inc.
 8200 N. Austin Avenue
 Morton Grove, Illinois 60053
 Phone: (847) 966-3700
 Fax: (847) 965-8379
www.xylem.com/brands/bellgossett

Bell & Gossett is a trademark of Xylem Inc. or one of its subsidiaries.
 © 2012 Xylem Inc. B-102A July 2012