

<b>JOB:</b>	<b>REPRESENTATIVE:</b>		
<b>UNIT TAG:</b>	<b>ORDER NO.</b>	<b>DATE:</b>	
<b>ENGINEER:</b>	<b>SUBMITTED BY:</b>	<b>DATE:</b>	
<b>CONTRACTOR:</b>	<b>APPROVED BY:</b>	<b>DATE:</b>	

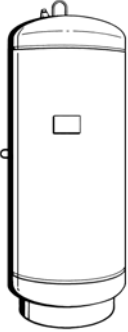

# Series "B-LA" (ASME)

## Pressurized Expansion Tanks

### Vertical

Not For Potable Water Systems

**DESCRIPTION**

Series "B-LA" expansion tanks are ASME rated precharged bladder-type pressure vessels. The Series "B-LA" tank is designed to absorb the expansion forces of heating/cooling system water while maintaining proper system pressurization under varying operating conditions. The replaceable heavy duty bladder contains system water thereby eliminating tank corrosion and waterlogging problems.

**CONSTRUCTION**

System Connection: Malleable Iron  
 Shell: Carbon Steel  
 Bladder: Replaceable Heavy Duty Butyl Rubber  
 Designed and Constructed per ASME Section VIII, Division 1

**MAXIMUM OPERATING LIMITS**

Maximum Design Pressure: 125 PSI (862kPa)  
 Design Temperature: 240°F (115°C)

**SCHEDULE**

PART NUMBER	MODEL NO.	TANK VOLUME GALLONS (LITERS)	ACCEPTANCE VOLUME GALLONS (LITERS)	TAGGING INFORMATION	QUANTITY
116782	B-35LA	10 (38)	10 (38)		
116783	B-50LA	13 (49)	11 (40)		
116784	B-85LA	22 (85)	11 (40)		
116785	B-100LA	26 (100)	11 (40)		
116786	B-130LA	34 (130)	27 (100)		
116787	B-165LA	44 (165)	27 (100)		
116788	B-200LA	53 (200)	27 (100)		
116789	B-300LA	80 (300)	27 (100)		
116790	B-400LA	106 (400)	53 (200)		
116791	B-500LA	132 (500)	53 (200)		
116792	B-600LA	158 (600)	53 (200)		

**TYPICAL SPECIFICATION**

Furnish and install as shown on plans a \_\_\_\_\_ gallon ( \_\_\_\_\_ liter) \_\_\_\_\_" ( \_\_\_\_\_ mm) diameter x \_\_\_\_\_" ( \_\_\_\_\_ mm) high pre-charged steel expansion tank with replaceable heavy duty Butyl rubber bladder. The tank shall have a 1" NPT system connection, 3/4" NPT drain, and a .302"-32NC charging valve connection (standard tire valve) to facilitate the on-site charging of the tank to meet system requirements.

The tank shall be fitted with lifting rings and a floor mounting skirt for vertical installation.

The tank must be constructed in accordance with Section VIII of the ASME Boiler and Pressure Vessel Code and stamped 125 PSI (862 kPa) working pressure.

Each tank shall be Xylem Industries – Bell & Gossett Model No. \_\_\_\_\_

NOTE: Tanks are factory pre-charged at 12 psi (83 kPa)

Tanks can be installed in the vertical position only.

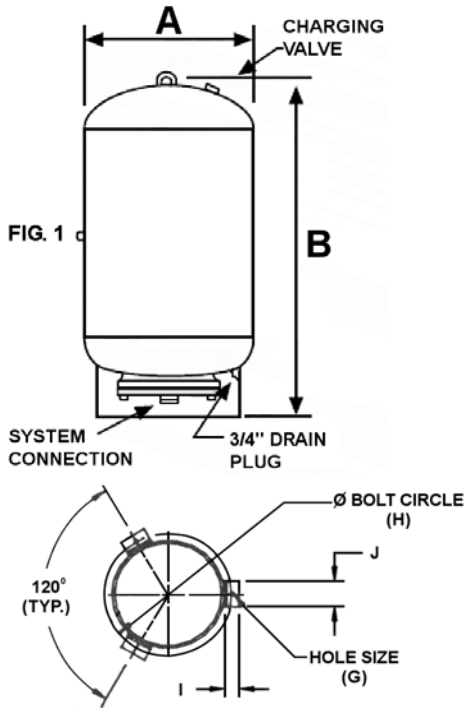

**OPTIONAL SEISMIC RESTRAINTS (FIG.2) - DIMENSIONS IN INCHES (MM)**

TANK DIAMETER	G	H	I	J
10"	9/16 (14)	12-5/8 (321)	2 (51)	2 (51)
12"	9/16 (14)	14-3/4 (375)	2 (51)	2 (51)
16"	9/16 (14)	16-3/4 (452)	2 (51)	2 (51)
20"	9/16 (14)	16-3/4 (452)	2 (51)	2 (51)
24"	9/16 (14)	18 (457)	2 (51)	2 (51)
30"	7/8 (22)	24 (610)	4 (102)	4 (102)

**DIMENSIONS: GALLONS (Ltrs) INCHES (mm), WEIGHTS: LBS. (KG)**

PART NUMBER	MODEL NUMBER	TANK VOLUME GAL (LTRS)	ACCEPTANCE VOLUME GAL (LTRS)	A IN. (MM)	B IN. (MM)	APPROX. SHPG. WT. LBS. (KG)	APPROX. WT* 100% FULL LBS. (KG)
116782	B-35LA	10 (38)	10 (38)	10 (254)	37-5/16 (948)	65 (29)	144 (67)
116783	B-50LA	13 (49)	11 (40)	12 (305)	37-1/16 (941)	72 (33)	164 (74)
116784	B-85LA	22 (85)	11 (40)	16 (406)	34-5/16 (872)	88 (40)	270 (122)
116785	B-100LA	26 (100)	11 (40)	16 (406)	39 (991)	94 (43)	308 (140)
116786	B-130LA	34 (130)	27 (100)	20 (508)	34-11/16 (881)	130 (59)	410 (186)
116787	B-165LA	44 (165)	27 (100)	20 (508)	39-11/16 (1008)	140 (63)	503 (228)
116788	B-200LA	53 (200)	27 (100)	24 (610)	40-7/8 (1039)	192 (87)	629 (285)
116789	B-300LA	80 (300)	27 (100)	24 (610)	56 (1423)	230 (104)	890 (404)
116790	B-400LA	106 (400)	53 (200)	24 (610)	68-5/8 (1743)	274 (124)	1148 (521)
116791	B-500LA	132 (500)	53 (200)	24 (610)	82-1/2 (2069)	308 (140)	1397 (634)
116792	B-600LA	158 (600)	53 (200)	30 (762)	67 (1702)	442 (200)	1745 (791)

Dimensions are subject to change. Not to be used for construction purposes.

System Connection: 1" NPT. Drain Plug 3/4"

\*Approximate weight 100% full occurs if bag fails or if air charge is lost.

Xylem Inc.  
8200 N. Austin Avenue  
Morton Grove, IL 60053  
Phone: (847)966-3700  
Fax: (847)965-8379  
www.xyleminc.com/brands/bellgossett

