

REPLACEMENT PARTS

CP-515C-PL

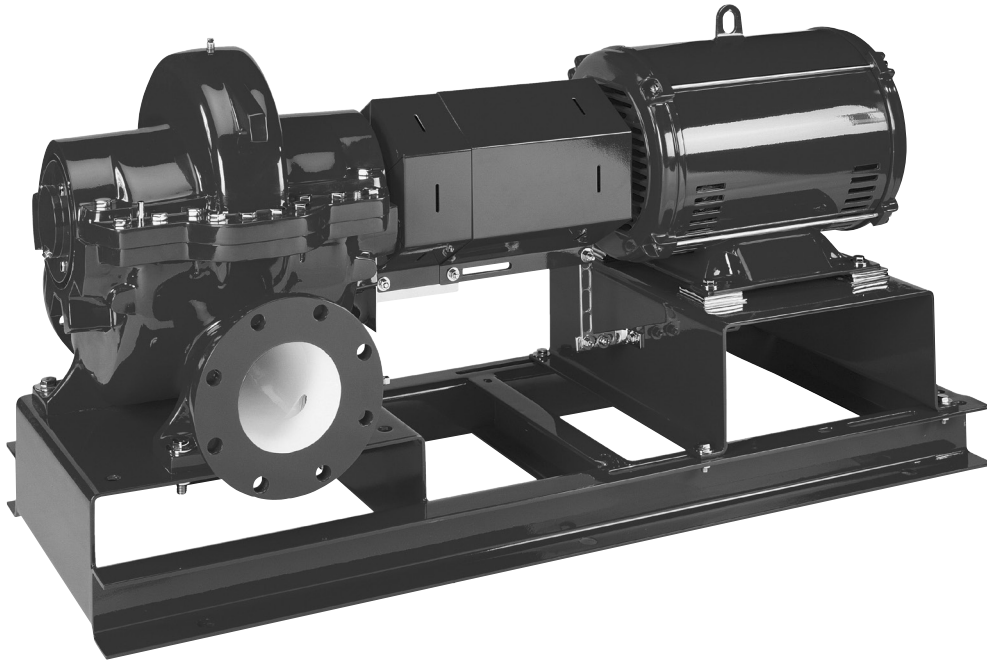

Series HSC³

Horizontal Split Case Pumps



Bell & Gossett

a xylem brand

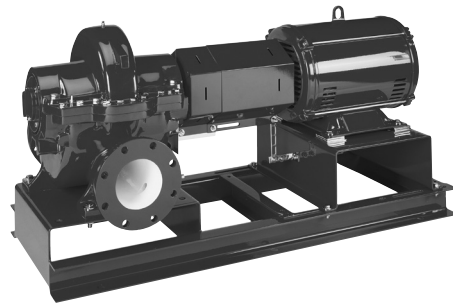

SERIES HSC³ PUMPS

INDEX

Exploded View.....	3
2x3x11S&L.....	4
4x6x10S,M.....	4
4x6x10M (with rings).....	4
4x6x10L,XL.....	5
4x6x10XL (with rings).....	5
4x6x10A.....	5
4x6x11.....	5
4x6x12S,M,L, XL.....	6
4x6x12XL (with rings).....	6
4x6x12A.....	6
4x6x14S,L.....	6
4x6x14A.....	7
6x8x10A.....	7
6x8x12S,L,XL.....	7
6x8x12M.....	7
6x8x12M (with rings).....	8
6x8x12XL (with rings).....	8
6x8x13.....	8
6x8x17M,L.....	8
8x8x12.....	9
8x8x17.....	9
8x10x12S,L.....	9
8x10x17S,L.....	10
8x10x20S,L.....	10
10x10x12.....	10
10x12x12M,XL.....	11
10x12x12XL (with rings).....	11
10x12x14.....	11
10x12x17.....	11
Coupling Selection (1200 & 1800 RPM).....	12
Coupling Selection (3600 RPM).....	13
ANSI/OSHA Coupling & Bracket Kit Selection Charts.....	Back page

HSC³ MECHANICAL SEAL OVER SHAFT EXPLODED VIEW

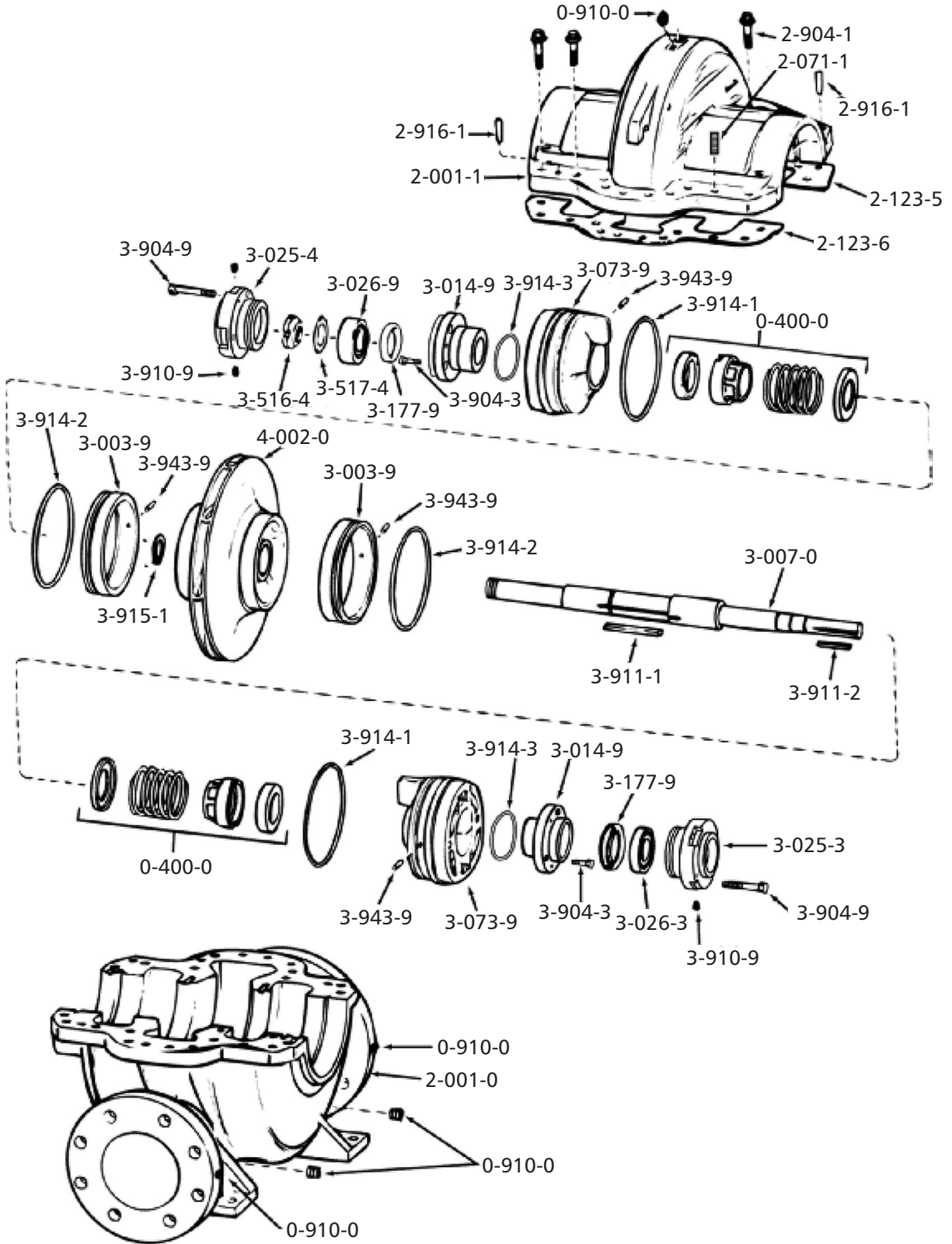

MECHANICAL SEAL OVER SHAFT

CAT. NO.	PART DESCRIPTION	QTY.	MATERIAL	2x3x11S,L	4X6X10 S,M	4x6x10M WITH RINGS
2-001-0	Casing	1	Cast Iron	52-116-916-501	52-116-917-501	52-116-917-511
2-071-1	Jacking Screw	2	Steel	CP-617-017-548	→	→
2-123-5	Casing Gasket-Suct.	1	Vellumoid	52-117-348-005	52-117-415-005	→
2-123-6	Casing Gasket Disch.	1	Vellumoid	52-117-347-005	52-117-414-005	→
2-904-1	Capscrew		Hardened Steel	CP-611-314-613	→	→
2-904-1	Capscrew		Hardened Steel	N/A	CP-611-314-617	→
2-904-1	Capscrew		Hardened Steel	CP-611-314-616	→	→
2-916-1	Casing Taper Pin	2	Steel	CP-671-139-491	→	→
3-003-9	Casing Ring Assy.	2	Bronze	52-117-232-501A	52-117-418-501A	52-117-118-501A
3-007-0	Shaft	1	416 Stainless Steel	52-261-507-001	52-261-581-001	→
3-014-9	Gland	2	Cast Iron	52-362-271-001	52-362-322-001	→
3-025-3	Brg. House (Inb.)	1	Cast Iron	52-362-269-001A	52-362-317-001A	→
3-025-4	Brg. House (Outb.)	1	Cast Iron	52-239-268-001A	52-362-318-001A	→
3-026-3	Bearing (Inb.)	1	Steel	52-113-300-006	CP-811-005-293	→
3-026-4	Bearing (Outb.)	1	Steel	CP-811-443-227	CP-811-443-269	→
3-073-9	Stuff Box Assy. (Left*)	1	Cast Iron	52-362-273-501A	52-462-489-501A	→
3-073-9	Stuff Box Assy. (Right*)	1	Cast Iron	52-362-273-501A	52-462-489-501A	→
3-177-9	Lip Seal	2	Rubber & Steel	CP-753-030-535	CP-753-030-907	→
3-516-4	Locknut, Brg.	1	Steel	CP-819-111-206	CP-819-111-207	→
3-517-4	Lockwasher, Brg.	1	Steel	CP-819-133-206	CP-819-133-207	→
3-904-3	Gland Bolt	6	Hardened Steel	AC8513	→	→
3-904-9	Bearing Housing Bolt	8	Hardened Steel	H52100	H28100	→
3-905-9	Alemite Fitting	2	Hardened Steel	AC2003	→	→
3-910-9	Pipe Plug	2	Hardened Steel	J04834	→	→
3-911-1	Impeller Key	1	Steel	CP-677-103-183	CP-677-051-146	→
3-911-2	Coupling Key	1	Steel	AC0522	CP-677-103-191	→
3-914-1	Stuff Box – O-Ring	2	Rubber	CP-751-531-954	→	→
3-914-2	Casing Ring – O-Ring	2	Rubber	CP-751-531-924	CP-751-561-028	CP-751-531-932
3-914-3	Gland - O-ring	2	Rubber	CP-751-531-096	CP-751-531-960	→
3-915-1	Snap Ring (Impeller)	1	420 Stn. Stl. Hardened	CP-673-201-168	CP-673-201-196	→
3-943-9	Cas. Ring, Spirol Pin	2	302 Stainless Steel	CP-671-181-371	→	→
3-943-9	Stuff Box Spirol Pin	2	302 Stainless Steel	CP-671-181-371	→	→
0-400-0	Mech. Seal, BF ₅₀ 10 ₁₀ 1	2	Buna/Ceramic	52-122-693-801A	52-122-693-802A	→
0-400-1	Mech. Seal, O ₂₈ P ₆₆ 10 ₁₀ 1	2	EPT/Ceramic	52-161-212-804A	52-161-212-805A	→
0-400-2	Mech. Seal, O ₂₈ P ₆₆ 10 ₁₅ 1	2	EPT/Tungsten Carb.	52-126-870-804A	52-126-870-805A	→
0-910-0	Pipe Plug, 0.25"		Hardened Steel	AC0532	→	→
0-910-0	Pipe Plug, 0.50"		Hardened Steel	H47900	→	→
0-910-0	Pipe Plug, 0.75/1.0"		Hardened Steel	CP-711-509-006	→	→
See Pages 12 and 13 for Model 150 Standard EPDM Coupling Selection.						
ANSI/OSHA Coupling & Bracket Kit Selection Charts see page 14.						
DIAMETER OF IMPELLER LISTED				11.00"	S-11.00"/ M-12.00"	12.00"
0-002-0	Impeller with Wear Rings "S" Size		Bronze	52-235-591-501	52-225-402-501	N/A
0-002-0	Impeller with Wear Rings "M" Size		Bronze	N/A	N/A	52-235-812-501
0-002-0	Impeller with Wear Rings "L" Size		Bronze	52-225-401-501	N/A	N/A
0-004-0	Impeller Wear Ring (2)		Bronze	08-998-120-001	08-975-856-001	08-998-246-001
4-002-0	Impeller "S" Size		Bronze	52-235-573-001	52-117-268-001	N/A
4-002-0	Impeller "M" Size		Bronze	N/A	52-233-459-001	N/A
4-002-0	Impeller "L" Size		Bronze	52-117-447-110	N/A	N/A
4-002-0	Impeller "XL" or "A" Size		Bronze	N/A	N/A	N/A

* When looking at pump from suction flange regardless of pump rotation

Factory Recommended Spare Parts

MECHANICAL SEAL OVER SHAFT

CAT. NO.	PART DESCRIPTION	QTY.	MATERIAL	4X6x10L,XL	4X6x10XL WITH RINGS	4x6x10A
2-001-0	Casing	1	Cast Iron	52-116-917-501	52-116-917-511	52-460-745-501
2-071-1	Jacking Screw	2	Steel	CP-617-017-548	→	→
2-123-6	Casing Gasket Disch.	1	Vellumoid	52-117-414-005	→	52-260-248-005
2-135-5	Casing Gasket-Suct.	1	Vellumoid	52-117-415-005	→	52-260-249-005
2-904-1	Capscrew		Hardened Steel	CP-611-314-613	→	CP-611-314-615
2-904-1	Capscrew		Hardened Steel	CP-611-314-617	→	CP-611-314-618
2-904-1	Capscrew		Hardened Steel	J92017	→	N/A
2-916-1	Casing Taper Pin	2	Steel	CP-671-139-491	→	→
3-003-9	Casing Ring Assy.	2	Bronze	52-117-418-501A	52-117-118-501A	→
3-007-0	Shaft	1	416 Stainless Steel	52-261-581-001	→	52-261-582-001
3-014-9	Gland	2	Cast Iron	52-362-322-001	→	52-362-271-001
3-025-3	Brg. House (Inb.)	1	Cast Iron	52-362-317-001A	→	52-362-269-001A
3-025-4	Brg. House (Outb.)	1	Cast Iron	52-362-318-001A	→	52-362-268-001A
3-026-3	Bearing (Inb.)	1	Steel	CP-811-005-293	→	52-113-300-006
3-026-4	Bearing (Outb.)	1	Steel	CP-811-443-269	→	CP-811-443-227
3-073-9	Stuff Box Assy. (Left*)	1	Cast Iron	52-462-489-501A	→	AC8433
3-073-9	Stuff Box Assy. (Right*)	1	Cast Iron	52-462-489-501A	→	AC8432
3-177-9	Lip Seal	2	Rubber & Steel	CP-753-030-907	→	→
3-516-4	Locknut, Brg.	1	Steel	CP-819-111-207	→	CP-819-111-206
3-517-4	Lockwasher, Brg.	1	Steel	CP-819-133-207	→	CP-819-133-206
3-904-3	Gland Bolt	6	Hardened Steel	AC8513	→	CP-315-142-373
3-904-9	Bearing Housing Bolt	8	Hardened Steel	H28100	→	H52100
3-905-9	Alemite Fitting	2	Hardened Steel	AC2003	→	→
3-910-9	Pipe Plug	2	Hardened Steel	J04834	→	→
3-911-1	Impeller Key	1	Steel	CP-677-051-146	→	CP-677-103-183
3-911-2	Coupling Key	1	Steel	CP-677-103-191	→	AC0522
3-914-1	Stuff Box – O-Ring	2	Rubber	CP-751-531-264	→	→
3-914-2	Casing Ring – O-Ring	2	Rubber	CP-751-561-028	CP-751-531-932	→
3-914-3	Gland - O-ring	2	Rubber	CP-751-531-960	→	CP-751-531-096
3-915-1	Snap Ring (Impeller)	1	420 Stn. Stil. Hardened	CP-673-201-196	→	CP-673-201-168
3-943-9	Cas. Ring, Spirol Pin	2	302 Stainless Steel	CP-671-181-371	→	→
3-943-9	Stuff Box Spirol Pin	2	302 Stainless Steel	CP-671-181-371	→	→
0-400-0	Mech. Seal, BF ₅₀ P _{10,10} 1	2	Buna/Ceramic	52-122-693-802A	→	52-122-693-801A
0-400-1	Mech. Seal, O ₂₈ P ₆₆ 10,101	2	EPT/Ceramic	52-161-212-805A	→	52-161-212-804A
0-400-2	Mech. Seal, O ₂₈ P ₆₆ 10,151	2	EPT/Tungsten Carb.	52-126-870-805A	→	52-126-870-804A
0-910-0	Pipe Plug, 0.25"		Hardened Steel	AC0532	→	→
0-910-0	Pipe Plug, 0.50"		Hardened Steel	H47900	→	→
0-910-0	Pipe Plug, 0.75/1.0"		Hardened Steel	AC1648	→	→

See Pages 12 and 13 for Model 150 Standard EPDM Coupling Selection.

ANSI/OSHA Coupling & Bracket Kit Selection Charts see page 14.

DIAMETER OF IMPELLER LISTED			12.00"	12.00"	12.00"
0-002-0	Impeller with Wear Rings "S" Size	Bronze	N/A	N/A	N/A
0-002-0	Impeller with Wear Rings "M" Size	Bronze	N/A	N/A	N/A
0-002-0	Impeller with Wear Rings "L" Size	Bronze	52-225-403-501	N/A	N/A
0-002-0	Impeller with Wear Rings "XL" Size	Bronze	N/A	52-260-229-501	N/A
0-004-0	Impeller Wear Ring (2)	Bronze	08-975-856-001	52-260-225-001	N/A
4-002-0	Impeller "S" Size	Bronze	N/A	N/A	N/A
4-002-0	Impeller "M" Size	Bronze	N/A	N/A	N/A
4-002-0	Impeller "L" Size	Bronze	N/A	N/A	N/A
4-002-0	Impeller "XL" or "A" Size	Bronze	52-360-238-001	N/A	AC2699

* When looking at pump from suction flange regardless of pump rotation

Factory Recommended Spare Parts

MECHANICAL SEAL OVER SHAFT

CAT. NO.	PART DESCRIPTION	QTY.	MATERIAL	4X6x12S,M,L,XL	4x6x12XL WITH RINGS	4x6x12A	4x6x14S,L
2-001-0	Casing	1	Cast Iron	52-116-918-501	52-129-588-501	52-116-917-511	52-116-919-501
2-071-1	Jacking Screw	2	Steel	CP-617-017-548	→	→	→
2-123-5	Casing Gasket-Suct.	1	Vellumoid	52-111-314-005	→	52-117-415-005	52-117-366-005
2-123-6	Casing Gasket Disch.	1	Vellumoid	52-111-315-005	→	52-117-414-005	52-117-367-005
2-904-1	Capscrew		Hardened Steel	CP-611-314-613	→	→	→
2-904-1	Capscrew		Hardened Steel	CP-611-314-617	→	→	J92017
2-904-1	Capscrew		Hardened Steel	N/A	N/A	CP-611-314-618	N/A
2-916-1	Casing Taper Pin	2	Steel	CP-671-139-491	→	→	→
3-003-9	Casing Ring Assy.	2	Bronze	52-117-118-501A	52-260-233-501A	52-117-118-501A	→
3-007-0	Shaft	1	416 Stainless Steel	52-261-582-001	→	52-261-581-001	52-261-582-001
3-014-9	Gland	2	Cast Iron	52-362-271-001	→	52-362-322-001	52-362-271-001
3-025-3	Brg. House (Inb.)	1	Cast Iron	52-362-269-001A	→	52-362-317-001A	52-362-269-001A
3-025-4	Brg. House (Outb.)	1	Cast Iron	52-362-268-001A	→	52-362-318-001A	52-362-268-001A
3-026-3	Bearing (Inb.)	1	Steel	52-113-300-006	→	CP-811-005-293	52-113-300-006
3-026-4	Bearing (Outb.)	1	Steel	CP-811-443-227	→	CP-811-443-269	CP-811-443-227
3-073-9	Stuff Box Assy. (Left*)	1	Cast Iron	52-462-491-501A	→	52-462-489-501A	52-462-491-501A
3-073-9	Stuff Box Assy. (Right*)	1	Cast Iron	52-462-491-501A	→	52-462-489-501A	52-462-491-501A
3-177-9	Lip Seal	2	Rubber & Steel	CP-753-030-535	→	CP-753-030-907	CP-753-030-535
3-516-4	Locknut, Brg.	1	Steel	CP-819-111-206	→	CP-819-111-207	CP-819-111-206
3-517-4	Lockwasher, Brg.	1	Steel	CP-819-133-206	→	CP-819-133-207	CP-819-133-206
3-904-3	Gland Bolt	6	Hardened Steel	AC8513	→	CP-315-142-373	AC8513
3-904-9	Bearing Housing Bolt	8	Hardened Steel	H52100	→	H28100	H52100
3-905-9	Alemite Fitting	2	Hardened Steel	AC2003	→	→	→
3-910-9	Pipe Plug	2	Hardened Steel	J04834	→	→	→
3-911-1	Impeller Key	1	Steel	CP-677-103-183	→	CP-677-051-146	CP-677-103-183
3-911-2	Coupling Key	1	Steel	AC0522	→	CP-677-103-191	AC0522
3-914-1	Stuff Box – O-Ring	2	Rubber	CP-751-531-264	→	→	→
3-914-2	Casing Ring – O-Ring	2	Rubber	CP-751-531-932	CP-751-531-934	CP-751-531-934	CP-751-531-932
3-914-3	Gland - O-ring	2	Rubber	CP-751-531-096	→	CP-751-531-960	CP-751-531-096
3-915-1	Snap Ring (Impeller)	1	420 Stn. Stl. Hardened	CP-673-201-168	→	CP-673-201-196	CP-673-201-168
3-943-9	Casing Ring, Spirol Pin	2	302 Stainless Steel	CP-671-181-371	→	→	→
3-943-9	Stuff Box Spirol Pin	2	302 Stainless Steel	CP-671-181-371	→	→	→
0-400-0	Mech. Seal, BF ₅₀ P _{10,10}	2	Buna/Ceramic	52-122-693-801A	→	52-122-693-802A	52-122-693-801A
0-400-1	Mech. Seal, O ₂₈ P ₆₆ 10,10	2	EPT/Ceramic	52-161-212-804A	→	52-161-212-805A	52-161-212-804A
0-400-2	Mech. Seal, O ₂₈ P ₆₆ 10,15	2	EPT/Tungsten Carb.	52-126-870-804A	→	52-126-870-805A	52-126-870-804A
0-910-0	Pipe Plug, 0.25"		Hardened Steel	AC0532	→	→	→
0-910-0	Pipe Plug, 0.50"		Hardened Steel	H47900	→	→	→
0-910-0	Pipe Plug, 0.75/1.0"		Hardened Steel	AC1648	→	→	→
See Pages 12 and 13 for Model 150 Standard EPDM Coupling Selection.							
ANSI/OSHA Coupling & Bracket Kit Selection Charts see page 14.							
DIAMETER OF IMPELLER LISTED				S,L-12.75"/ M-12.20"	13.80"	13.80"	13.80"
0-002-0	Impeller with Wear Rings "S" Size		Bronze	52-221-003-501	N/A	N/A	52-225-190-501
0-002-0	Impeller with Wear Rings "M" Size		Bronze	52-261-544-508	N/A	N/A	N/A
0-002-0	Impeller with Wear Rings "L" Size		Bronze	52-221-556-501	N/A	N/A	52-225-405-501
0-002-0	Impeller with Wear Rings "XL" Size		Bronze	N/A	52-260-230-501	N/A	N/A
0-004-0	Impeller Wear Ring (2)		Bronze	08-998-246-001**	52-260-226-001	N/A	08-998-246-001
4-002-0	Impeller "S" Size		Bronze	52-321-684-001	N/A	N/A	52-117-222-001
4-002-0	Impeller "M" Size		Bronze	52-460-558-000	N/A	N/A	N/A
4-002-0	Impeller "L" Size		Bronze	52-323-030-000	N/A	N/A	52-117-374-001
4-002-0	Impeller "XL" or "A" Size		Bronze	52-360-236-001	N/A	AC8447	N/A

* When looking at pump from suction flange regardless of pump rotation

** For 4x6x12L impeller assemblies only. For 4x6x12M impeller assembly, use wear ring #52-161-420-001.

Factory Recommended Spare Parts

MECHANICAL SEAL OVER SHAFT

CAT. NO.	PART DESCRIPTION	QTY.	MATERIAL	4x6x14A	6x8x10A	6x8x12S,L,XL
2-001-0	Casing	1	Cast Iron	52-116-918-501	AC2440	52-116-920-501
2-071-1	Jacking Screw	2	Steel	CP-617-017-548	→	CP-617-017-548
2-123-5	Casing Gasket-Suct.	1	Vellumoid	52-111-314-005	AC2437	52-111-310-005
2-123-6	Casing Gasket Disch.	1	Vellumoid	52-111-315-005	AC2438	52-111-311-005
2-904-1	Capscrew		Hardened Steel	CP-611-314-613	CP-611-314-615	→
2-904-1	Capscrew		Hardened Steel	CP-611-314-617	N/A	J92017
2-916-1	Casing Taper Pin	2	Steel	CP-671-139-491	→	→
3-003-9	Casing Ring Assy.	2	Bronze	52-117-233-501A	AC8486	52-117-117-501A
3-007-0	Shaft	1	416 Stainless Steel	52-261-582-001	AC2710	52-261-582-001
3-014-9	Gland	2	Cast Iron	52-362-271-001	52-362-322-001	52-362-271-001
3-025-3	Brg. House (Inb.)	1	Cast Iron	52-362-269-001A	52-362-317-001A	52-362-269-001A
3-025-4	Brg. House (Outb.)	1	Cast Iron	52-362-268-001A	52-362-318-001A	52-362-268-001A
3-026-3	Bearing (Inb.)	1	Steel	52-113-300-006	CP-811-005-293	52-113-300-006
3-026-4	Bearing (Outb.)	1	Steel	CP-811-443-227	CP-811-443-269	CP-811-443-227
3-073-9	Stuff Box Assy. (Left*)	1	Cast Iron	52-462-491-501A	AC2434	52-462-491-501A
3-073-9	Stuff Box Assy. (Right*)	1		52-462-491-501A	AC2433	52-462-491-501A
3-177-9	Lip Seal	2	Rubber & Steel	CP-753-030-535	CP-753-030-907	CP-753-030-535
3-516-4	Locknut, Brg.	1	Steel	CP-819-111-206	CP-819-111-207	CP-819-111-206
3-517-4	Lockwasher, Brg.	1	Steel	CP-819-133-206	CP-819-133-207	CP-819-133-206
3-904-3	Gland Bolt	6	Hardened Steel	CP-315-142-373	→	→
3-904-9	Bearing Housing Bolt	8	Hardened Steel	H52100	DJ0076	H52100
3-905-9	Alemite Fitting	2	Hardened Steel	AC2003	→	→
3-910-9	Pipe Plug	2	Hardened Steel	J04834	→	→
3-911-1	Impeller Key	1	Steel	CP-677-103-183	CP-677-051-146	CP-677-103-183
3-911-2	Coupling Key	1	Steel	AC0522	CP-677-103-191	AC0522
3-914-1	Stuff Box – O-Ring	2	Rubber	CP-751-531-264	→	→
3-914-2	Casing Ring – O-Ring	2	Rubber	CP-751-531-934	CP-751-531-937	→
3-914-3	Gland - O-ring	2	Rubber	CP-751-531-096	CP-751-531-960	CP-751-531-096
3-915-1	Snap Ring (Impeller)	1	420 Stn. Stl. Hardened	CP-673-201-168	CP-673-201-196	CP-673-201-168
3-943-9	Cas. Ring, Spirol Pin	2	302 Stainless Steel	CP-671-181-371	→	→
3-943-9	Stuff Box Spirol Pin	2	302 Stainless Steel	CP-671-181-371	→	→
0-400-0	Mech. Seal, BF ₅₀ P ₁₀ 1	2	Buna/Ceramic	52-122-693-801A	52-122-693-802A	52-122-693-801A
0-400-1	Mech. Seal, O ₂₈ P ₆₆ 10 ₁₀ 1	2	EPT/Ceramic	52-161-212-804A	52-161-212-805A	52-161-212-804A
0-400-2	Mech. Seal, O ₂₈ P ₆₆ 10 ₁₅ 1	2	EPT/Tungsten Carb.	52-126-870-804A	52-126-870-805A	52-126-870-804A
0-910-0	Pipe Plug, 0.25"		Hardened Steel	AC0532	→	→
0-910-0	Pipe Plug, 0.50"		Hardened Steel	H47900	→	→
0-910-0	Pipe Plug, 0.75/1.0"		Hardened Steel	AC1648	→	→

See Pages 12 and 13 for Model 150 Standard EPDM Coupling Selection.

ANSI/OSHA Coupling & Bracket Kit Selection Charts see page 14.

DIAMETER OF IMPELLER LISTED			13.80"	10.00"	12.80"
0-002-0	Impeller with Wear Rings "S" Size	Bronze	N/A	N/A	52-238-621-501
0-002-0	Impeller with Wear Rings "M" Size	Bronze	N/A	N/A	N/A
0-002-0	Impeller with Wear Rings "L" Size	Bronze	N/A	N/A	52-220-846-501
0-002-0	Impeller with Wear Rings "XL" Size	Bronze	N/A	N/A	N/A
0-002-0	Impeller with Wear Rings "S" Size	Cast Iron	N/A	N/A	52-238-620-501
0-002-0	Impeller with Wear Rings "M" Size	Cast Iron	N/A	N/A	N/A
0-002-0	Impeller with Wear Rings "L" Size	Cast Iron	N/A	N/A	52-225-677-501
0-004-0	Impeller Wear Ring (2)	Bronze	N/A	N/A	52-115-029-001
0-004-0	Impeller Wear Ring (2)	Cast Iron	N/A	N/A	52-115-029-002
4-002-0	Impeller "S" Size	Bronze	N/A	N/A	52-117-327-001
4-002-0	Impeller "M" Size	Bronze	N/A	N/A	N/A
4-002-0	Impeller "L" Size	Bronze	N/A	N/A	52-322-152-000
4-002-0	Impeller "XL" or "A" Size	Bronze	AC8449	AC8481	52-360-234-001
4-002-0	Impeller "S" Size	Cast Iron	N/A	N/A	52-118-459-001
4-002-0	Impeller "L" Size	Cast Iron	N/A	N/A	52-322-152-050

* When looking at pump from suction flange regardless of pump rotation

Factory Recommended Spare Parts

MECHANICAL SEAL OVER SHAFT

CAT. NO.	PART DESCRIPTION	QTY.	MATERIAL	6X8x12M WITH RINGS	6X8x12XL WITH RINGS	6x8x13	6x8x17M,L
2-001-0	Casing	1	Cast Iron	52-116-920-514	→	52-118-401-501	52-116-921-501
2-071-1	Jacking Screw	2	Steel	CP-617-017-548	→	→	→
2-123-5	Casing Gasket-Suct.	1	Vellumoid	52-122-310-005	→	52-122-059-005	52-122-061-005
2-123-6	Casing Gasket Disch.	1	Vellumoid	52-122-311-005	→	52-122-060-005	52-112-062-005
2-904-1	Capscrew		Hardened Steel	CP-611-314-615	→	→	→
2-904-1	Capscrew		Hardened Steel	J92017	→	→	→
2-916-1	Casing Taper Pin	2	Steel	CP-671-139-491	→	→	→
3-003-9	Casing Ring Assy.	2	Bronze	52-126-809-501A	→	08-104-599-507A	08-104-599-510A
3-007-0	Shaft	1	416 Stainless Steel	52-261-582-001	→	52-261-521-001	→
3-014-9	Gland	2	Cast Iron	52-362-322-001	52-362-271-001	52-362-322-001	→
3-025-3	Brg. House (Inb.)	1	Cast Iron	52-362-317-001A	52-362-269-001A	52-362-317-001A	→
3-025-4	Brg. House (Outb.)	1	Cast Iron	52-362-318-001A	52-362-268-001A	52-362-318-001A	→
3-026-3	Bearing (Inb.)	1	Steel	CP-811-005-293	52-113-300-001	CP-811-005-293	→
3-026-4	Bearing (Outb.)	1	Steel	CP-811-443-269	CP-811-443-227	CP-811-443-269	→
3-073-9	Stuff Box Assy. (Left*)	1	Cast Iron	52-962-491-501A	52-962-489-501A	52-462-487-501A	→
3-073-9	Stuff Box Assy. (Right*)	1	Cast Iron	52-962-491-501A	52-962-489-501A	52-462-487-501A	→
3-177-9	Lip Seal	2	Rubber & Steel	CP-753-030-907	CP-753-030-535	CP-753-030-907	→
3-516-4	Locknut, Brg.	1	Steel	CP-819-111-207	CP-819-111-206	CP-819-111-207	→
3-517-4	Lockwasher, Brg.	1	Steel	CP-819-133-207	CP-819-133-206	CP-819-133-207	→
3-904-3	Gland Bolt	6	Hardened Steel	AC8513	→	→	→
3-904-9	Bearing Housing Bolt	8	Hardened Steel	H28100	H52100	H28100	→
3-905-9	Alemite Fitting	2	Hardened Steel	AC2003	→	→	→
3-910-9	Pipe Plug	2	Hardened Steel	J04834	→	→	→
3-911-1	Impeller Key	1	Steel	CP-677-103-183	→	CP-677-051-153	→
3-911-2	Coupling Key	1	Steel	AC0522	→	CP-677-103-191	→
3-914-1	Stuff Box – O-Ring	2	Rubber	CP-751-531-268	→	CP-751-531-268	→
3-914-2	Casing Ring – O-Ring	2	Rubber	CP-751-531-938	CP-751-531-937	CP-751-531-940	CP-751-531-939
3-914-3	Gland - O-ring	2	Rubber	CP-751-531-960	CP-751-531-096	CP-751-531-960	→
3-915-1	Snap Ring (Impeller)	1	420 Stn. Stl. Hardened	CP-673-201-196	→	→	→
3-943-9	Casing Ring, Spirol Pin	2	302 Stainless Steel	CP-671-181-371	→	→	→
3-943-9	Stuff Box Spirol Pin	2	302 Stainless Steel	CP-671-181-371	→	→	→
0-400-0	Mech. Seal, BF ₅₀ P ₁₀ 1	2	Buna/Ceramic	52-122-693-802A	52-122-693-801A	52-122-693-802A	→
0-400-1	Mech. Seal, O ₂₈ P ₆₆ 10 ₁₀ 1	2	EPT/Ceramic	52-161-212-805A	52-161-212-804A	52-161-212-805A	→
0-400-2	Mech. Seal, O ₂₈ P ₆₆ 10 ₁₅ 1	2	EPT/Tungsten Carb.	52-126-870-805A	52-126-870-804A	52-126-870-805A	→
0-910-0	Pipe Plug, 0.25"		Hardened Steel	AC0532	→	→	→
0-910-0	Pipe Plug, 0.50"		Hardened Steel	H47900	→	→	→
0-910-0	Pipe Plug, 0.75/1.0"		Hardened Steel	AC1648	→	→	→
See Pages 12 and 13 for Model 150 Standard EPDM Coupling Selection.							
ANSI/OSHA Coupling & Bracket Kit Selection Charts see page 14.							
DIAMETER OF IMPELLER LISTED				12.80"	13.40"	13.10"	17.00"
0-002-0	Impeller with Wear Rings "M" Size		Bronze	52-236-592-501	N/A	52-220-825-564	52-225-078-501
0-002-0	Impeller with Wear Rings "L" Size		Bronze	N/A	N/A	N/A	52-220-693-506
0-002-0	Impeller with Wear Rings "XL" Size		Bronze	N/A	52-260-231-501	N/A	N/A
0-002-0	Impeller "M" Size		Cast Iron	52-239-976-501	N/A	N/A	N/A
0-004-0	Impeller Wear Ring (2)		Bronze	52-126-810-001	52-260-227-001	08-982-211-002	08-978-606-001
0-004-0	Impeller Wear Ring (2)		Cast Iron	52-126-810-003	N/A	N/A	N/A
4-002-0	Impeller "M" Size		Bronze	N/A	N/A	08-105-173-065	52-117-099-001
4-002-0	Impeller "L" Size		Bronze	N/A	N/A	N/A	08-105-900-006

* When looking at pump from suction flange regardless of pump rotation

Factory Recommended Spare Parts

MECHANICAL SEAL OVER SHAFT

CAT. NO.	PART DESCRIPTION	QTY.	MATERIAL	8x8x12	8x8x17	8x10x12S,L
2-001-0	Casing	1	Cast Iron	52-116-968-501	52-116-922-501	52-116-923-501
2-071-1	Jacking Screw	2	Steel	CP-617-017-548	→	→
2-123-6	Casing Gasket Disch.	1	Vellumoid	52-122-063-005	52-122-065-005	52-122-067-005
2-135-5	Casing Gasket-Suct.	1	Vellumoid	52-122-064-005	52-122-066-005	52-122-068-005
2-904-1	Capscrew		Hardened Steel	CP-611-314-615	→	→
2-904-1	Capscrew		Hardened Steel	J92017	→	→
2-916-1	Casing Taper Pin	2	Steel	CP-671-139-491	→	→
3-003-9	Casing Ring Assy.	2	Bronze	08-104-599-501A	08-104-599-507A	08-104-599-501A
3-007-0	Shaft	1	416 Stainless Steel	52-261-521-001	52-362-387-001	→
3-014-9	Gland	2	Cast Iron	52-362-322-001	52-362-329-001	→
3-025-3	Brg. House (Inb.)	1	Cast Iron	52-362-317-001A	52-362-332-001A	→
3-025-4	Brg. House (Outb.)	1	Cast Iron	52-362-318-001A	52-362-333-001A	→
3-026-3	Bearing (Inb.)	1	Steel	CP-811-005-293	52-113-301-009	→
3-026-4	Bearing (Outb.)	1	Steel	CP-811-443-269	CP-811-443-295	→
3-073-9	Stuff Box Assy. (Left*)	1	Cast Iron	52-462-487-501A	52-462-482-501A	→
3-073-9	Stuff Box Assy. (Right*)	1	Cast Iron	52-462-487-501A	52-462-482-501A	→
3-177-9	Lip Seal	2	Rubber & Steel	CP-753-030-907	CP-753-383-021	→
3-516-4	Locknut, Brg.	1	Steel	CP-819-111-207	CP-819-111-208	→
3-517-4	Lockwasher, Brg.	1	Steel	CP-819-133-207	CP-819-133-208	→
3-904-3	Gland Bolt	6	Hardened Steel	AC8513	→	→
3-904-9	Bearing Housing Bolt	8	Hardened Steel	H28100	H28200	→
3-905-9	Alemite Fitting	2	Hardened Steel	AC2003	→	→
3-910-9	Pipe Plug	2	Hardened Steel	J04834	→	→
3-911-1	Impeller Key	1	Steel	CP-677-051-153	CP-677-051-246	→
3-911-2	Coupling Key	1	Steel	CP-677-103-191	CP-677-103-238	→
3-914-1	Stuff Box – O-Ring	2	Rubber	CP-751-531-268	CP-751-531-270	→
3-914-2	Casing Ring – O-Ring	2	Rubber	CP-751-531-944	CP-751-531-940	CP-751-531-944
3-914-3	Gland - O-ring	2	Rubber	CP-751-531-960	CP-751-531-917	→
3-915-1	Snap Ring (Impeller)	1	420 Stn. Stl. Hardened	CP-673-201-196	CP-673-201-243	→
3-943-9	Casing Ring, Spirol Pin	2	302 Stainless Steel	CP-671-181-371	→	→
3-943-9	Stuff Box Spirol Pin	2	302 Stainless Steel	CP-671-181-371	→	→
0-400-0	Mech. Seal, BF ₅₀ 10 ₁₀ 1	2	Buna/Ceramic	52-122-693-802A	52-122-693-807A	→
0-400-1	Mech. Seal, O ₂₈ P ₆₆ 10 ₁₀ 1	2	EPT/Ceramic	52-161-212-805A	52-161-212-806A	→
0-400-2	Mech. Seal, O ₂₈ P ₆₆ 10 ₁₅ 1	2	EPT/Tungsten Carb.	52-126-870-805A	52-126-870-806A	→
0-910-0	Pipe Plug, 0.25"		Hardened Steel	AC0532	→	→
0-910-0	Pipe Plug, 0.50"		Hardened Steel	H47900	→	→
0-910-0	Pipe Plug, 0.75/1.0"		Hardened Steel	AC1648	→	→
See Pages 12 and 13 for Model 150 Standard EPDM Coupling Selection.						
ANSI/OSHA Coupling & Bracket Kit Selection Charts see page 14.						
DIAMETER OF IMPELLER LISTED				12.80"	17.70"	12.80"
0-002-0	Impeller with Wear Rings "S" Size		Bronze	N/A	N/A	52-220-877-501
0-002-0	Impeller with Wear Rings "M" Size		Bronze	52-220-692-501	52-220-784-502	N/A
0-002-0	Impeller with Wear Rings "L" Size		Bronze	N/A	N/A	52-221-827-501
0-004-0	Impeller Wear Ring (2)		Bronze	08-996-357-004	08-982-211-002	08-107-221-001
4-002-0	Impeller "S" Size		Bronze	N/A	N/A	08-105-840-001
4-002-0	Impeller "M" Size		Bronze	08-105-084-001	08-105-687-059	N/A
4-002-0	Impeller "L" Size		Bronze	N/A	N/A	52-115-223-001

* When looking at pump from suction flange regardless of pump rotation
 Factory Recommended Spare Parts

MECHANICAL SEAL OVER SHAFT

CAT. NO.	PART DESCRIPTION	QTY.	MATERIAL	8x10x17S,L	8x10x20S,L	10x10x12
2-001-0	Casing	1	Cast Iron	52-116-924-501	52-128-321-501	52-116-925-501
2-071-1	Jacking Screw	2	Steel	CP-617-017-548	→	→
2-123-6	Casing Gasket Disch.	1	Vellumoid	52-122-070-005	52-239-078-005	52-122-072-005
2-135-5	Casing Gasket-Suct.	1	Vellumoid	52-122-069-005	52-239-077-005	52-122-071-005
2-904-1	Capscrew		Hardened Steel	CP-611-314-613	N/A	CP-611-314-613
2-904-1	Capscrew		Hardened Steel	CP-611-314-615	→	→
2-916-1	Casing Taper Pin	2	Steel	CP-671-139-491	→	→
3-003-9	Casing Ring Assy.	2	Bronze	08-104-599-501A	52-328-631-501A	08-104-599-504A
3-007-0	Shaft	1	416 Stainless Steel	52-362-387-001	→	52-362-335-001
3-014-9	Gland	2	Cast Iron	52-362-329-001	→	→
3-025-3	Brg. House (Inb.)	1	Cast Iron	52-362-332-001A	→	→
3-025-4	Brg. House (Outb.)	1	Cast Iron	52-362-333-002A	→	→
3-026-3	Bearing (Inb.)	1	Steel	52-113-301-009	→	→
3-026-4	Bearing (Outb.)	1	Steel	CP-811-443-295	→	→
3-073-9	Stuff Box Assy. (Left*)	1	Cast Iron	52-462-482-501A	→	→
3-073-9	Stuff Box Assy. (Right*)	1	Cast Iron	52-462-482-501A	→	→
3-177-9	Lip Seal	2	Rubber & Steel	CP-753-383-021	→	→
3-516-4	Locknut, Brg.	1	Steel	CP-819-111-208	→	→
3-517-4	Lockwasher, Brg.	1	Steel	CP-819-133-208	→	→
3-904-3	Gland Bolt	6	Hardened Steel	AC8513	→	→
3-904-9	Bearing Housing Bolt	8	Hardened Steel	H28200	→	→
3-905-9	Alemite Fitting	2	Hardened Steel	AC2003	→	→
3-910-9	Pipe Plug	2	Hardened Steel	J04834	→	→
3-911-1	Impeller Key	1	Steel	CP-677-051-246	→	→
3-911-2	Coupling Key	1	Steel	CP-677-103-238	→	→
3-914-1	Stuff Box – O-Ring	2	Rubber	CP-751-531-270	→	→
3-914-2	Casing Ring – O-Ring	2	Rubber	CP-751-531-944	CP-751-531-949	→
3-914-3	Gland - O-ring	2	Rubber	CP-751-531-917	→	→
3-915-1	Snap Ring (Impeller)	1	420 Stn. Stl. Hardened	CP-673-201-243	→	→
3-943-9	Casing Ring, Spirol Pin	2	302 Stainless Steel	CP-671-181-371	→	→
3-943-9	Stuff Box Spirol Pin	2	302 Stainless Steel	CP-671-181-371	→	→
0-400-0	Mech. Seal, BF ₅₀ P ₁₀ 1	2	Buna/Ceramic	52-122-693-807A	→	→
0-400-1	Mech. Seal, O ₂₈ P ₆₆ 10 ₁₀ 1	2	EPT/Ceramic	52-161-212-806A	→	→
0-400-2	Mech. Seal, O ₂₈ P ₆₆ 10 ₁₅ 1	2	EPT/Tungsten Carb.	52-126-870-806A	→	→
0-910-0	Pipe Plug, 0.25"		Hardened Steel	AC0532	→	→
0-910-0	Pipe Plug, 0.50"		Hardened Steel	H47900	→	→
0-910-0	Pipe Plug, 0.75/1.0"		Hardened Steel	AC1648	→	→

See Pages 12 and 13 for Model 150 Standard EPDM Coupling Selection.

ANSI/OSHA Coupling & Bracket Kit Selection Charts see page 14.

DIAMETER OF IMPELLER LISTED			S-17.70"/ L-17.3"	20.20"	12.80"
0-002-0	Impeller with Wear Rings "S" Size	Bronze	52-220-811-564	52-327-903-501	N/A
0-002-0	Impeller with Wear Rings "M" Size	Bronze	N/A	N/A	52-220-757-501
0-002-0	Impeller with Wear Rings "L" Size	Bronze	52-225-622-501	52-327-907-501	N/A
0-004-0	Impeller Wear Ring (2)	Bronze	08-996-357-004	08-999-049-002	08-999-049-002
4-002-0	Impeller "S" Size	Bronze	08-105-085-057	52-327-901-001	N/A
4-002-0	Impeller "M" Size	Bronze	N/A	N/A	08-105-316-001
4-002-0	Impeller "L" Size	Bronze	52-322-941-001	52-327-909-001	N/A

* When looking at pump from suction flange regardless of pump rotation

Factory Recommended Spare Parts

MECHANICAL SEAL OVER SHAFT

CAT. NO.	PART DESCRIPTION	QTY.	MATERIAL	10x12x12M,XL	10X12x12XL WITH RINGS	10x12x14	10x12x17
2-001-0	Casing	1	Cast Iron	52-116-926-501	52-129-590-501	52-128-803-501	→
2-071-1	Jacking Screw	2	Steel	CP-617-017-548	→	→	→
2-123-6	Casing Gasket Disch.	1	Vellumoid	52-122-074-005	→	52-128-805-005	→
2-135-5	Casing Gasket-Suct.	1	Vellumoid	52-122-073-005	→	52-128-806-005	→
2-904-1	Capscrew		Hardened Steel	N/A	N/A	CP-611-314-613	→
2-904-1	Capscrew		Hardened Steel	CP-611-314-615	→	→	→
2-904-1	Capscrew		Hardened Steel	J92017	→	CP-617-511-691	→
2-916-1	Casing Taper Pin	2	Steel	CP-671-139-491	→	→	→
3-003-9	Casing Ring Assy.	2	Bronze	08-104-599-518A	52-260-234-501A	08-104-599-504A	→
3-007-0	Shaft	1	416 Stainless Steel	52-362-335-001	→	52-362-387-001	→
3-014-9	Gland	2	Cast Iron	52-362-329-001	→	→	→
3-025-3	Brg. House (Inb.)	1	Cast Iron	52-362-332-001A	→	→	→
3-025-4	Brg. House (Outb.)	1	Cast Iron	52-362-333-001A	→	→	→
3-026-3	Bearing (Inb.)	1	Steel	52-113-301-009	→	→	→
3-026-4	Bearing (Outb.)	1	Steel	CP-811-443-295	→	→	→
3-073-9	Stuff Box Assy. (Left*)	1	Cast Iron	52-462-482-501A	→	→	→
3-073-9	Stuff Box Assy. (Right*)	1	Cast Iron	52-462-482-501A	→	→	→
3-177-9	Lip Seal	2	Rubber & Steel	CP-753-383-021	→	→	→
3-516-4	Locknut, Brg.	1	Steel	CP-819-111-208	→	→	→
3-517-4	Lockwasher, Brg.	1	Steel	CP-819-133-208	→	→	→
3-904-3	Gland Bolt	6	Hardened Steel	AC8513	→	→	→
3-904-9	Bearing Housing Bolt	8	Hardened Steel	H28200	→	→	→
3-905-9	Alernite Fitting	2	Hardened Steel	AC2003	→	→	→
3-910-9	Pipe Plug	2	Hardened Steel	J04834	→	→	→
3-911-1	Impeller Key	1	Steel	CP-677-051-246	→	→	→
3-911-2	Coupling Key	1	Steel	CP-677-103-238	→	→	→
3-914-1	Stuff Box – O-Ring	2	Rubber	CP-751-531-270	→	→	→
3-914-2	Casing Ring – O-Ring	2	Rubber	CP-751-531-991	→	CP-751-531-949	→
3-914-3	Gland - O-ring	2	Rubber	CP-751-531-917	→	→	→
3-915-1	Snap Ring (Impeller)	1	420 Stn. Stl. Hardened	CP-673-201-243	→	→	→
3-943-9	Casing Ring, Spirol Pin	2	302 Stainless Steel	CP-671-181-371	→	→	→
3-943-9	Stuff Box Spirol Pin	2	302 Stainless Steel	CP-671-181-371	→	→	→
0-400-0	Mech. Seal, BF ₅₀ P ₁₀ 1	2	Buna/Ceramic	52-122-693-807A	→	→	→
0-400-1	Mech. Seal, O ₂₈ P ₆₆ 10 ₁₀ 1	2	EPT/Ceramic	52-161-212-806A	→	→	→
0-400-2	Mech. Seal, O ₂₈ P ₆₆ 10 ₁₅ 1	2	EPT/Tungsten Carb.	52-126-870-806A	→	→	→
0-910-0	Pipe Plug, 0.25"		Hardened Steel	AC0532	→	→	→
0-910-0	Pipe Plug, 0.50"		Hardened Steel	H47900	→	→	→
0-910-0	Pipe Plug, 0.75/1.0"		Hardened Steel	AC1648	→	→	→

See Pages 12 and 13 for Model 150 Standard EPDM Coupling Selection.

ANSI/OSHA Coupling & Bracket Kit Selection Charts see page 14.

DIAMETER OF IMPELLER LISTED			M-12.70"/ XL-13.50"	13.50"	14.00"	17.50"
0-002-0	Impeller with Wear Rings "M" Size	Bronze	52-220-756-501	N/A	52-225-036-501	52-220-694-501
0-002-0	Impeller with Wear Rings "XL" Size	Bronze	N/A	52-260-488-501	N/A	N/A
0-004-0	Impeller Wear Ring (2)	Bronze	08-975-994-001	52-260-487-001	08-999-049-002	08-999-049-002
4-002-0	Impeller "M" Size	Bronze	08-105-924-053	N/A	52-116-699-001	08-105-086-001
4-002-0	Impeller "XL" or "A" Size	Bronze	52-360-503-001	N/A	N/A	N/A

* When looking at pump from suction flange regardless of pump rotation

Factory Recommended Spare Parts

**SERIES HSC³ MODEL 150 STANDARD COUPLING SELECTION
EPDM STANDARD TO 324T, HYTREL STANDARD 326T & ABOVE**

Pump Models with 1200 RPM ODP Motor

PUMP	PUMP SHAFT	PUMP HALF	MOTOR FRAME SIZE	MOTOR HP	MOTOR SHAFT	MOTOR HALF	SLEEVE NO.	VENDOR ID
2x3x11S,L	1-1/8"	52-219-923-159	182T-184T	1 1/2-2	1-1/8"	AC1559	AC1440	5E
4X6X10A	1-1/8"	52-219-923-259	254T-256T	7 1/2-10	1-5/8"	AC1465	AC1442	7E
4x6x12S,M,L,XL	1-1/8"	52-219-923-309	284T	15	1-7/8"	AC1469	AC1443	8E
4x6x14S,L,A	1-1/8"	52-219-923-359	286T	20	1-7/8"	AC1472	AC1444	9E
6x8x12S,L,XL	1-1/8"	52-219-923-359	324T	25	2-1/8"	AC1473	AC1444	9E
	1-1/8"	52-219-923-359	326T	30	2-1/8"	AC1477	AC1445	9HS
4x6x10S,M,L,XL	1-3/8"	AC1562	182T-184T	1 1/2-2	1-1/8"	AC1561	AC1441	6E
4x6x11	1-3/8"	AC1562	213T-215T	3-5	1-3/8"	AC1562	AC1441	6E
4X6X12A	1-3/8"	AC1464	254T-256T	7 1/2-10	1-3/8"	AC1465	AC1442	7E
6x8x10A	1-3/8"	AC1467	284T	15	1-5/8"	AC1469	AC1443	8E
6x8x12M	1-3/8"	AC1470	286T	20	1-7/8"	AC1472	AC1444	9E
6x8x13	1-3/8"	AC1470	324T	25	2-1/8"	AC1473	AC1444	9E
6x8x17M,L	1-3/8"	AC1470	326T	30	2-1/8"	AC1473	AC1446	9HS
8x8x17	1-5/8"	AC1465	254T-256T	7 1/2-10	1-5/8"	AC1465	AC1442	7E
8x10x12S,L	1-5/8"	AC1468	284T	15	1-7/8"	AC1469	AC1443	8E
8x10x17S,L	1-5/8"	AC1471	286T	20	1-7/8"	AC1472	AC1444	9E
8x10x20S,L	1-5/8"	AC1471	324T	25	2-1/8"	AC1473	AC1444	9E
10x10x12	1-5/8"	AC1471	326T	30	2-1/8"	AC1473	AC1446	9HS
10x12x12M,XL	1-5/8"	AC1471	364T	40	2-3/8"	52-219-923-369	AC1446	9HS
10x12x14	1-5/8"	AC1471	365T	50	2-3/8"	52-219-923-369	AC1446	9HS
10x12x17	1-5/8"	AC1471	404T	60	2-7/8"	52-219-923-373	AC1446	9HS
	1-5/8"	AC1471	405T	75	2-7/8"	52-219-923-373	AC1446	9HS

Pump Models With 1800 RPM ODP Motor

PUMP	PUMP SHAFT	PUMP HALF	MOTOR FRAME SIZE	MOTOR HP	MOTOR SHAFT	MOTOR HALF	SLEEVE NO.	VENDOR ID
2x3x11S,L	1-1/8"	52-219-923-159	182T-184T	3-5	1-1/8"	AC1559	AC1440	5E
4x6x12S,M,L,XL	1-1/8"	AC1561	213T-215T	7 1/2-10	1-3/8"	AC1562	AC1441	6E
4x6x14S,L,A	1-1/8"	52-219-923-529	254T	15	1-5/8"	AC1465	AC1442	7E
6x8x12S,L,XL	1-1/8"	52-219-923-309	256T	20	1-5/8"	AC1468	AC1443	8E
	1-1/8"	52-219-923-309	284T	25	1-7/8"	AC1469	AC1443	8E
	1-1/8"	52-219-923-359	286T	30	1-7/8"	AC1472	AC1444	9E
	1-1/8"	52-219-923-359	324T	40	2-1/8"	AC1473	AC1444	9E
	1-1/8"	52-219-923-359	326T	50	2-1/8"	AC1473	AC1446	9HS
4x6x10S,M,L,XL	1-3/8"	AC1562	182T-184T	3-5	1-1/8"	AC1561	AC1441	6E
4x6x11	1-3/8"	AC1562	213T	7 1/2-10	1-3/8"	AC1562	AC1441	6E
4x6x12A	1-3/8"	AC1464	254T	15	1-5/8"	AC1465	AC1442	7E
6x8x10A	1-3/8"	AC1467	256T	20	1-5/8"	AC1468	AC1443	8E
6x8x12M	1-3/8"	AC1467	284T	25	1-7/8"	AC1469	AC1443	8E
6x8x13	1-3/8"	AC1470	286T	30	1-7/8"	AC1472	AC1444	9E
6x8x17M,L	1-3/8"	AC1470	324T	40	2-1/8"	AC1473	AC1444	9E
8x8x12	1-3/8"	AC1470	326T	50	2-1/8"	AC1473	AC1446	9HS
8x8x17	1-5/8"	AC1465	254T	15	1-5/8"	AC1465	AC1442	7E
8x10x12S,L	1-5/8"	AC1468	256T	20	1-5/8"	AC1468	AC1443	8E
8x10x17S,L	1-5/8"	AC1468	284T	25	1-7/8"	AC1469	AC1443	8E
8x10x20S,L	1-5/8"	AC1471	286T	30	1-7/8"	AC1472	AC1444	9E
10x10x12	1-5/8"	AC1471	324T	40	2-1/8"	AC1473	AC1444	9E
10x12x12M,XL	1-5/8"	AC1471	326T	50	2-1/8"	AC1473	AC1446	9HS
10x12x14	1-5/8"	AC1468	364TS	60	1-7/8"	AC1469	P82142	8H
10x12x17	1-5/8"	AC1468	365TS	75	1-7/8"	AC1469	P82142	8H
	1-5/8"	AC1471	404TS-405TS	100	2-1/8"	AC1473	AC1446	9HS
	1-5/8"	AC1471	405T	125	2-7/8"	52-219-923-373	AC1446	9HS
	1-5/8"	AC1471	444TS	150	2-3/8"	52-219-923-369	AC1446	9HS

**SERIES HSC³ MODEL 150 STANDARD COUPLING SELECTION
EPDM STANDARD TO 324TS, HYTREL STANDARD 326TS & ABOVE**

Pump Models with 3600 RPM ODP Motor

PUMP	PUMP SHAFT	PUMP HALF	MOTOR FRAME SIZE	MOTOR HP	MOTOR SHAFT	MOTOR HALF	SLEEVE NO.	VENDOR ID
2x3x11S,L	1-1/8"	52-219-923-159	182T-184T	5-7 ½	1-1/8"	AC1559	AC1440	5E
	1-1/8"	AC1561	213T-215T	10-15	1-3/8"	AC1562	AC1441	6E
	1-1/8"	52-219-923-259	254T-256T	20-25	1-5/8"	AC1465	AC1442	7E
	1-1/8"	52-219-923-259	284TS-286TS	30	1-5/8"	AC1465	AC1442	7E
	1-1/8"	52-219-923-309	286TS	40	1-5/8"	AC1468	AC1443	8E
	1-1/8"	52-219-923-309	324TS-326TS	50	1-7/8"	AC1469	AC1443	8E
	1-1/8"	52-219-923-359	326TS	60	1-7/8"	AC1469	P82142	8H
4x6x10M	1-3/8"	AC1464	254T-256T	20-25	1-5/8"	AC1465	AC1442	7E
6x8x12M	1-3/8"	AC1464	284TS	30	1-5/8"	AC1465	AC1442	7E
	1-3/8"	AC1467	286TS	40	1-5/8"	AC1468	AC1443	8E
	1-3/8"	AC1467	324TS-326TS	50	1-7/8"	AC1469	AC1443	8E
	1-3/8"	AC1467	326TS	60	1-7/8"	AC1469	P82142	8H
	1-3/8"	AC1467	364TS	75	1-7/8"	AC1469	P82142	8H
	1-3/8"	AC1467	365TS	100	1-7/8"	AC1469	P82142	8H
	1-3/8"	AC1470	404TS-405TS	100-125	2-1/8"	AC1473	AC1446	9HS
	1-3/8"	AC1470	444TS-445TS	200	2-3/8"	52-219-923-369	AC1446	9HS

Note: Contact factory for replacement non-standard HSC Series 150 couplings and all HSC Series 300 couplings.

These couplings selections are only representative of the many available dependent upon motor frame size. Consult factory fo

ANSI/OSHA GUARD & BRACKET KIT SELECTION CHART FOR SERIES HSC³ PUMPS

COUPLER GUARD KIT PART NUMBERS: 1 = 186884 2 = 186885 3 = 186888 4 = 186886 5 = 186889
6 = 186887 7 = 185327 C = CONSULT FACTORY

SERIES HSC³ MODEL 150 WITH STANDARD EPDM COUPLING (EPDM 143-324 MTR FRAMES, HYTREL 326 & ABOVE)

PUMP SIZE	BRACKET	MOTOR FRAME / GUARD KIT NUMBER																																							
		143T	145T	182T	184T	213T	215T	254T	256T	284T	284TS	286T	286TS	324T	324TS	326T	326TS	364T	364TS	365T	365TS	404T	404TS	405T	405TS	444T	444TS	445T	445TS	447T	447TS	449T	449TS								
2x3x11S,L	1DN001	1	1	1	1	2	2	2	2	2	2	2	2	2	2	2	2	2	2	6	6																				
4x6x10S,M,L,XL	1DN002			2	2	2	2	2	2	2	2	2	2	2	2	2	2	2	2	7	7	7	6	7	6	C	C	C	C												
4x6x10A	1DN063			1	1	2	2	2	2	2	2	2	2	2	2	2	2	2	2																						
4x6x11	1DN002			2	2	2	2	2	2	2	2	2	2	2	2	2	2	2	2	7	7	7	6	7	6	C	C	C	C												
4x6x12S,M,L,XL	1DN001			1	1	2	2	2	2	2	2	2	2	2	2	2	2	2	2	6	6																				
4x6x12A	1DN064					2	2	2	2	2	2	2	2	2	2	2	2	2	2	2	2	2	2	2	2	C	C														
4x6x14S,L	1DN001			1	1	2	2	2	2	2	2	2	2	2	2	2	2	2	2	6	6																				
4X6X14A	1DN063							2	2	2	2	2	2	2	2	2	2	2	2	2	2	2	2	2	2	C	C	C	C												
6x8x10A	1DN064							2	2	2	2	2	2	2	2	2	2	2	2	6	6	6	6	6	6	C	C														
6x8x12S,L,XL	1DN001			1	1	2	2	2	2	2	2	2	2	2	2	2	2	2	2	2	2	2	2	2	6	6															
6x8x12M	1DN002							2	2	2	2	2	2	2	2	2	2	2	2	7	7	7	6	7	6	C	C	C	C												
6x8x13	1DN002							2	2	2	2	2	2	2	2	2	2	2	2	7	7	7	7	7	7																
6x8x17M,L	1DN002									2	2	2	2	2	2	2	2	2	2	7	7	7	7	7	7	C	C	C	C												
8x8x12	1DN002							2	2	2	2	2	2	2	2	2	2	2	2	7	7	7	7	7	7																
8x8x17	1DN003													7	7	7	7	7	7	7	7	7	7	7	7	7	7	7	7	7	7	7	7	7	C	C	C	C	C	C	
8x10x12S,L	1DN003							7	7	7	7	7	7	7	7	7	7	7	7	7	7	7	7	7	7	7	7	7	7	7	7	7	7	7	7	C	C	C	C	C	C
8x10x17S,L	1DN003													7	7	7	7	7	7	7	7	7	7	7	7	7	7	7	7	7	7	7	7	7	7	C	C	C	C	C	C
8x10x20S,L	1DN003													7	7	7	7	7	7	7	7	7	7	7	7	7	7	7	7	7	7	7	7	7	7	C	C	C	C	C	C
10x10x12	1DN003									7	7	7	7	7	7	7	7	7	7	7	7	7	7	7	7	7	7	7	7	7	7	7	7	7	7	C	C	C	C	C	C
10x12x12M,XL	1DN003									7	7	7	7	7	7	7	7	7	7	7	7	7	7	7	7	7	7	7	7	7	7	7	7	7	7	C	C	C	C	C	C
10x12x14	1DN003													7	7	7	7	7	7	7	7	7	7	7	7	7	7	7	7	7	7	7	7	7	7	C	C	C	C	C	C
10x12x17	1DN003													7	7	7	7	7	7	7	7	7	7	7	7	7	7	7	7	7	7	7	7	7	7	C	C	C	C	C	C

SERIES HSC³ MODEL 150 WITH WOODS EPDM SPACER COUPLING (EPDM 143-324, HYTREL 326 & ABOVE)

PUMP SIZE	BRACKET KIT	MOTOR FRAME / GUARD KIT NUMBER																																						
		143T	145T	182T	184T	213T	215T	254T	256T	284T	284TS	286T	286TS	324T	324TS	326T	326TS	364T	364TS	365T	365TS	404T	404TS	405T	405TS	444T	444TS	445T	445TS	447T	447TS	449T	449TS							
2x3x11S,L	1DN001	2	2	2	2	2	2	3	3	3	2	3	2	3	2	3	2	3	3	7	7																			
4x6x10S,M,L,XL	1DN002			3	3	3	3	3	3	3	3	3	3	3	3	3	3	3	3	5	3	7	7	C	7	C	C	C	C											
4x6x10A	1DN063			C	C	C	C	C	C	C	C	C	C	C	C																									
4x6x11	1DN002			3	3	3	3	3	3	3	3	3	3	3	3	3	3	3	3	5	3	7	7	C	7	C	C	C	C											
4x6x12S,M,L,XL	1DN001			2	2	2	2	3	3	3	2	3	2	3	2	3	2	3	3	7	7																			
4x6x12A	1DN064							C	C	C	C	C	C	C	C	C	C	C	C	C	C	C	C	C	C	C	C													
4x6x14S,L	1DN001			2	2	2	2	3	3	3	2	3	2	3	2	3	2	3	3	7	7																			
4X6X14A	1DN063					2	2	2	2	2	2	2	2	2	2	2	2	2	2	2	2	2	2	2	2	C	C	C	C											
6x8x10A	1DN064							C	C	C	C	C	C	C	C	C	C	C	C	C	C	C	C	C	C	C	C													
6x8x12S,L,XL	1DN001			2	2	2	2	3	3	3	2	3	2	3	2	3	2	3	3	7	7																			
6x8x12M	1DN002							3	3	3	3	3	3	3	3	3	3	3	3	5	3	7	7	C	7	C	C	C	C											
6x8x13	1DN002							3	3	3	3	3	3	3	3	3	3	3	3	5	3	7	7	C	7	C	C	C	C											
6x8x17M,L	1DN002									3	3	3	3	3	3	3	3	3	3	5	3	7	7	C	7	C	C	C	C											
8x8x12	1DN002							3	3	3	3	3	3	3	3	3	3	3	3	5	3	7	7	C	7	C	C	C												
8x8x17	1DN003													5	7	5	7	4	7	5	7	5	5	C	5	C	C	C	C	C	C	C	C	C	C	C	C	C	C	
8x10x12S,L	1DN003							7	7	5	7	5	7	5	7	5	7	4	7	5	7	5	5	C	5	C	C	C	C	C	C	C	C	C	C	C	C	C	C	C
8x10x17S,L	1DN003													5	7	5	7	4	7	5	7	5	5	C	5	C	C	C	C	C	C	C	C	C	C	C	C	C	C	
8x10x20S,L	1DN003													5	7	5	7	4	7	5	7	5	5	C	5	C	C	C	C	C	C	C	C	C	C	C	C	C	C	
10x10x12	1DN003									5	7	5	7	5	7	5	7	4	7	5	7	5	5	C	5	C	C	C	C	C	C	C	C	C	C	C	C	C	C	C
10x12x12M,XL	1DN003									5	7	5	7	5	7	5	7	4	7	5	7	5	5	C	5	C	C	C	C	C	C	C	C	C	C	C	C	C	C	C
10x12x14	1DN003													5	7	5	7	4	7	5	7	5	5	C	5	C	C	C	C	C	C	C	C	C	C	C	C	C	C	
10x12x17	1DN003													5	7	5	7	4	7	5	7	5	5	C	5	C	C	C	C	C	C	C	C	C	C	C	C	C	C	

HOW TO USE THESE CHARTS TO SELECT A COUPLER GUARD AND BRACKET KIT:

Example (shaded grey above): Pump Model = 4x6x12S,M,L,XL w/ a 50 HP, 460 Volt,3 PH, 1800 RPM, 326T Frame motor.

The Coupler Guard kit is 186885 and would require a 1DN001 bracket kit.



Xylem Inc.
8200 N. Austin Avenue
Morton Grove, Illinois 60053
Phone: (847) 966-3700
Fax: (847) 965-8379
www.bellgossett.com