

# Series HSC & HSC-S

## Horizontal Split Case Pumps

Replacement Parts



## PACKING OVER SHAFT SLEEVE

### INDEX

PAGE	DESCRIPTION
3	Packing Over Shaft Sleeve Exploded View
4	2x3x11S&L, 4X6X10a, 4x6x10M
5	4x6x12A, 4x6x14A, 4x6x14L
6	6x8x12S&L, 6x8x12M, 6x8x12XL
7	6x8x13, 6x8x17M&L, 8x8x12, 8x8x17, 8x10x12S&L
8	8x10x17S&L, 8x10x20S&L, 10x10x12, 10x12x12M
9	10x12x12XL, 10x12x14, 10x12x17
	<b>Conversion Tables</b>
26	Packing to Mech. Seal Over Sleeve
27	Packing to Mech. Seal Over Shaft
30-31	Series 150 Standard EDPM Coupling Selection
32	ANSI/OSHA Coupling & Bracket Kit Selection Charts

### FRAME DESIGNATION

PUMP SIZE	FRAME	PUMP SIZE	FRAME
2x3x11S&L	F20-A4	6x8x17M&L	F20-D4
4x6x10A	F20-C4	8x8x12	F20-D4
4x6x10M	F20-B4	8x8x17	F20-E4
4x6x12A	F20-B4	8x10x12S&L	F20-E4
4x6x14A,L	F20-C4	8x10x17S&L	F20-E4
6x8x10A	F20-I4	8x10x20S&L	F20-E4
6x8x12S&L	F20-C4	10x10x12	F20-F4
6x8x12XL	F20-C4	10x12x12M&XL	F20-F4
6x8x12M	F20-B4	10x12x14	F20-E4
6x8x13	F20-D4	10x12x17	F20-E4



## PACKING OVER SHAFT SLEEVE

CAT. NO.	PART DESCRIPTION	QTY.	MATERIAL	2x3x11S,L	4x6x10A	4x6x10M IMP. ONLY	4x6x10M IMP. ASSY. ONLY
2-001-0	Casing	1	Cast Iron	52-116-916-501	52-460-745-501	52-116-917-501	52-116-917-511
2-123-5	Casing Gasket-Suct.	1	Vellumoid	52-117-348-005	52-260-249-005	52-117-415-005	>
2-123-6	Casing Gasket-Disch.	1	Vellumoid	52-117-347-005	52-260-248-005	52-117-414-005	>
2-904-1	Capscrew		Hardened Steel	CP-611-314-613	CP-611-314-615	>	>
2-904-1	Capscrew		Hardened Steel	N/A	CP-611-314-618	CP-611-314-617	>
2-904-1	Capscrew		Hardened Steel	CP-611-314-616	J92017	>	>
2-916-1	Casing Taper Pin	2	Steel	CP-671-139-491	>	>	>
3-003-9	Casing Ring Assy.	2	Bronze	52-117-232-501	52-117-118-501	52-117-418-501	52-117-118-501
3-003-9	Casing Ring Assy.	2	Cast Iron	52-117-232-502	52-117-118-502	52-117-418-502	52-117-118-502
3-003-9	Casing Ring Assy.	2	Nitronic 60	52-127-084-501	52-127-084-503	52-127-084-502	52-127-084-503
3-943-9	Cas. Ring, Spirol Pin	2	302 Stainless Steel	CP-671-181-371	52-105-715-020	CP-671-181-371	>
3-914-2	Casing Ring – O-Ring	1	Rubber	CP-751-531-924	CP-751-531-932	CP-751-561-028	CP-751-531-932
3-914-1	Stuff Box – O-Ring	1	Rubber	CP-751-531-954	CP-751-531-264	CP-751-531-264	>
3-911-2	Coupling Key	1	Steel	AC0522	>	CP-677-103-191	>
3-911-1	Impeller Key	1	Steel	CP-677-103-183	>	CP-677-051-146	>
3-025-3	Brg. House (Inb.)	1	Cast Iron	52-239-562-001	>	>	>
3-025-4	Brg. House (Outb.)	1	Cast Iron	52-239-563-001	>	>	>
3-026-3	Bearing (Inb.)	1	Steel	52-113-300-006	>	>	>
3-026-4	Bearing (Outb.)	1	Steel	CP-811-443-227	>	>	>
3-516-4	Locknut, Brg.	1	Steel	CP-819-111-206	>	>	>
3-517-4	Lockwasher, Brg.	1	Steel	CP-819-133-206	>	>	>
3-177-9	Lip Seal	2	Rubber & Steel	CP-753-030-535	>	>	>
3-136-9	Deflector	2	Rubber & Steel	52-117-840-002	>	>	>
3-904-9	Brg. Hsg. Screw (Inb.)	2	Steel	DJ0081	>	>	>
3-904-9	Brg. Hsg. Screw (Outb.)	2	Steel	CP-611-271-482	>	>	>
3-073-9	Stuff Box Assy.	2	Cast Iron	52-427-336-501	AC8439/AC8440	52-427-361-501	>
3-943-0	Stuff Box Spirol Pin	2	302 Stainless Steel	CP-671-181-371	>	>	>
3-009-9	Shaft Sleeve	2	Bronze	52-239-532-501	52-239-536-501	52-239-534-501	>
3-009-9	Shaft Sleeve	2	316 Stainless Steel	52-239-532-504	52-239-536-504	52-239-534-504	>
3-009-9	Shaft Sleeve	2	420 Stn. Sil. Hardened	52-239-532-502	52-239-536-502	52-239-534-502	>
0-944-0	Shaft Sleeve Lock Pin	2	316 Stainless Steel	52-114-088-007	>	>	>
3-914-9	Sleeve, O-Ring	2	Rubber	CP-751-531-428	>	AC0545	>
3-015-9	Shaft Nut	2	Bronze	52-128-640-001	>	52-128-641-001	>
3-015-0	Shaft Nut	2	Nitronic 60	52-128-640-002	>	52-128-641-002	>
3-902-3	Shaft Nut Setscrew	2	316 Stainless Steel	CP-617-039-366	>	>	>
3-007-0	Shaft	1	1045 Steel	52-239-341-001	52-360-245-001	52-239-343-001	>
3-007-0	Shaft	1	316 Stainless Steel	52-239-341-002	52-239-343-002	>	>
3-007-0	Shaft	1	4140 Steel	52-239-341-003	52-239-343-003	>	>
1-924-9	Packing	10	Graphite Acrylic Yarn	AC6128	>	52-328-740-222	>
1-014-9	Gland	2	Bronze	52-224-259-501	>	08-104-772-501	>
1-904-9	Gland Screw	4	Steel	H28100	CP-611-327-472	P01260	>
1-909-9	Gland Washer	4	Steel	CP-651-001-214	>	AC1502	>
1-013-9	Seal Cage (Optional)	2	Teflon	52-430-298-017	>	52-430-298-028	>
0-952-0	Seal Piping Parts (Optional)	1	Plastic	52-127-292-501	>	>	>
0-952-0	Seal Piping Parts (Optional)	1	Copper	52-127-292-502	>	>	>
Model 150 Standard EPDM Coupling Selection. See Pages 33 and 34.							
ANSI/OSHA Coupling & Bracket Kit Selection Charts. See Pages 35.							
DIAMETER OF IMPELLER LISTED				11.00"	9.80"	S,L – 11.00"/ M – 12.00"	12.00"
0-002-0	Imp. Assy. (Small Cap)		Bronze	52-235-591-501	N/A	52-225-402-501	N/A
0-002-0	Imp. Assy. (Med. Cap)		Bronze	N/A	N/A	N/A	52-235-812-501
0-002-0	Imp. Assy. (Lrg. Cap)		Bronze	52-225-401-501	N/A	52-225-403-501	N/A
0-004-0	Imp. Wear Ring		Bronze	08-998-120-001	N/A	08-975-856-001	08-998-246-001
4-002-0	Impeller (Small Cap)		Bronze	52-235-573-001	N/A	52-117-268-001	N/A
4-002-0	Impeller (Med. Cap)		Bronze	N/A	N/A	52-233-459-001	N/A
4-002-0	Impeller (Lrg. Cap)		Bronze	52-117-447-110	N/A	52-117-343-001	N/A
4-002-0	Impeller (XL Cap)		Bronze	N/A	AC2699	N/A	N/A

Factory Recommended Spare Parts

**Note: Part sheets valid for pumps manufactured after June 1999. Serial number must be provided for pumps manufactured prior to this date.**

**PACKING OVER SHAFT SLEEVE**

CAT. NO.	PART DESCRIPTION	QTY.	MATERIAL	4x6x12A	4x6x14A	4x6x14L
2-001-0	Casing	1	Cast Iron	52-116-917-511	52-129-588-501	52-116-919-501
2-123-5	Casing Gasket-Suct.	1	Vellumoid	52-117-415-005	52-111-314-005	52-117-366-005
2-123-6	Casing Gasket-Disch.	1	Vellumoid	52-117-414-005	52-111-315-005	52-111-367-005
2-904-1	Capscrew		Hardened Steel	CP-611-314-615	>	CP-611-314-613
2-904-1	Capscrew		Hardened Steel	CP-611-314-618	N/A	CP-611-314-618
2-904-1	Capscrew		Hardened Steel	N/A	J92017	J92017
2-916-1	Casing Taper Pin	2	Steel	CP-671-139-491	>	>
3-003-9	Casing Ring Assy.	2	Bronze	52-117-118-501	52-260-233-501	52-117-118-501
3-003-9	Casing Ring Assy.	2	Cast Iron	52-117-118-502	52-260-233-502	52-117-118-502
3-003-9	Casing Ring Assy.	2	Nitronic 60	52-127-084-503	N/A	52-127-084-503
3-943-9	Cas. Ring, Spirol Pin	2	302 Stainless Steel	52-105-715-020	>	CP-671-181-371
3-914-2	Casing Ring - O-Ring	1	Rubber	CP-751-531-932	CP-751-531-934	CP-751-531-932
3-914-1	Stuff Box - O-Ring	1	Rubber	CP-751-531-264	>	CP-751-531-264
3-911-2	Coupling Key	1	Steel	CP-677-103-191	AC0522	>
3-911-1	Impeller Key	1	Steel	CP-677-051-146	CP-677-103-183	>
3-025-3	Brg. House (Inb.)	1	Cast Iron	52-239-562-001	>	>
3-025-4	Brg. House (Outb.)	1	Cast Iron	52-239-563-001	>	>
3-026-3	Bearing (Inb.)	1	Steel	52-113-300-006	>	>
3-026-4	Bearing (Outb.)	1	Steel	CP-811-443-227	>	>
3-516-4	Locknut, Brg.	1	Steel	CP-819-111-206	>	>
3-517-4	Lockwasher, Brg.	1	Steel	CP-819-133-206	>	>
3-177-9	Lip Seal	2	Rubber & Steel	CP-753-030-535	>	>
3-136-9	Deflector	2	Rubber & Steel	52-117-840-002	>	>
3-904-9	Brg. Hsg. Screw (Inb.)	2	Steel	DJ0081	>	>
3-904-9	Brg. Hsg. Screw (Outb.)	2	Steel	CP-611-271-482	>	>
3-073-9	Stuff Box Assy.	2	Cast Iron	52-427-361-501	52-427-285-501	>
3-943-9	Stuff Box Spirol Pin	2	302 Stainless Steel	CP-671-181-371	>	>
3-009-9	Shaft Sleeve	2	Bronze	52-239-534-501	52-239-536-501	>
3-009-9	Shaft Sleeve	2	316 Stainless Steel	52-239-534-504	52-239-536-504	>
3-009-9	Shaft Sleeve	2	420 Stn. Stil. Hardened	52-239-534-502	52-239-536-502	>
0-944-0	Shaft Sleeve Lock Pin	2	316 Stainless Steel	52-114-088-007	>	>
3-914-9	Sleeve, O-Ring	2	Rubber	CP-751-531-428	>	>
3-015-9	Shaft Nut	2	Bronze	52-128-641-001	>	52-128-640-001
3-015-9	Shaft Nut	2	Nitronic 60	52-128-641-002	>	52-128-640-002
3-902-3	Shaft Nut Setscrew	2	316 Stainless Steel	CP-617-039-366	>	>
3-007-0	Shaft	1	1045 Steel	52-239-345-001	>	>
3-007-0	Shaft	1	316 Stainless Steel	52-239-345-002	>	>
3-007-0	Shaft	1	4140 Steel	52-239-345-003	>	>
1-924-9	Packing	10	Graphite Acrylic Yarn	AC6129	AC6128	>
1-014-9	Gland	2	Bronze	08-104-772-501	52-224-259-501	>
1-904-9	Gland Screw	4	Steel	CP-611-327-552	>	H28100
1-909-9	Gland Washer	4	Steel	AC1502	CP-651-001-214	>
1-013-9	Seal Cage (Optional)	2	Teflon	52-430-298-028	52-430-298-017	>
0-952-0	Seal Piping Parts (Optional)	1	Plastic	52-127-292-501	>	>
0-952-0	Seal Piping Parts (Optional)	1	Copper	52-127-292-502	>	>
Model 150 Standard EPDM Coupling Selection. See Pages 33 and 34.						
ANSI/OSHA Coupling & Bracket Kit Selection Charts. See Pages 35.						
<b>DIAMETER OF IMPELLER LISTED</b>				<b>12.00"</b>	<b>13.80"</b>	<b>12.00"</b>
0-002-0	Imp. Assy. (Small Cap)		Bronze	N/A	N/A	52-225-190-501
0-002-0	Imp. Assy. (Lrg. Cap)		Bronze	N/A	N/A	52-225-405-501
0-004-0	Imp. Wear Ring		Bronze	N/A	N/A	08-998-246-001
4-002-0	Impeller (Small Cap)		Bronze	N/A	N/A	52-117-222-001
4-002-0	Impeller (Lrg. Cap)		Bronze	AC8447	AC8449	52-117-374-001

Factory Recommended Spare Parts

Note: Part sheets valid for pumps manufactured after June 1999. Serial number must be provided for pumps manufactured prior to this date.

**PACKING OVER SHAFT SLEEVE**

CAT. NO.	PART DESCRIPTION	QTY.	MATERIAL	6x8x12S,L	6x8X12M IMP. ONLY	6x8x12M IMP. ASSY. ONLY	6x8x12XL IMP. ONLY	6x8x12XL IMP. ASSY. ONLY
2-001-0	Casing	1	Cast Iron	52-116-920-501	>	52-116-920-514	52-116-920-501	52-116-920-514
2-123-5	Casing Gasket-Suct.	1	Vellumoid	52-111-310-005	>	>	>	>
2-123-6	Casing Gasket-Disch.	1	Vellumoid	52-111-311-005	>	>	>	>
2-904-1	Capscrew		Hardened Steel	CP-611-314-615	>	>	>	>
2-904-1	Capscrew		Hardened Steel	J92017	>	>	>	>
2-916-1	Casing Taper Pin	2	Steel	CP-671-139-491	>	>	>	>
3-003-9	Casing Ring Assy.	2	Bronze	52-117-117-501	>	52-126-809-501	52-117-117-501	52-126-809-501
3-003-9	Casing Ring Assy.	2	Cast Iron	52-118-082-501	>	52-126-809-502	52-118-082-501	52-126-809-502
3-003-9	Casing Ring Assy.	2	Nitronic 60	52-127-084-504	>	52-127-084-510	52-127-084-504	N/A
3-943-9	Cas. Ring, Spirol Pin	2	302 Stainless Steel	CP-671-181-371	>	>	>	>
3-914-2	Casing Ring – O-Ring	1	Rubber	CP-751-531-937	>	CP-751-531-938	CP-751-531-937	>
3-914-1	Stuff Box – O-Ring	1	Rubber	CP-751-531-264	>	>	>	>
3-911-2	Coupling Key	1	Steel	AC0522	CP-677-103-191	>	AC0522	>
3-911-1	Impeller Key	1	Steel	CP-677-103-183	CP-677-051-146	>	CP-677-103-183	>
3-025-3	Brg. House (Inb.)	1	Cast Iron	52-239-562-001	52-239-566-001	>	52-239-562-001	>
3-025-4	Brg. House (Outb.)	1	Cast Iron	52-239-563-001	52-239-567-001	>	52-239-563-001	>
3-026-3	Bearing (Inb.)	1	Steel	52-113-300-006	CP-811-005-293	>	52-113-300-006	>
3-026-4	Bearing (Outb.)	1	Steel	CP-811-443-227	CP-811-443-269	>	CP-811-443-227	>
3-516-4	Locknut, Brg.	1	Steel	CP-819-111-206	CP-819-111-207	>	CP-819-111-206	>
3-517-4	Lockwasher, Brg.	1	Steel	CP-819-133-206	CP-819-133-207	>	CP-819-133-206	>
3-177-9	Lip Seal	2	Rubber & Steel	CP-753-030-535	CP-753-030-907	>	CP-753-030-535	>
3-136-9	Deflector	2	Rubber & Steel	52-117-840-002	52-108-475-009	>	52-117-840-002	>
3-904-9	Brg. Hsg. Screw (Inb.)	2	Steel	DJ0081	CP-611-271-482	>	DJ0081	>
3-904-9	Brg. Hsg. Screw (Outb.)	2	Steel	CP-611-271-482	CP-611-271-484	>	CP-611-271-482	>
3-073-9	Stuff Box Assy.	2	Cast Iron	52-427-285-501	52-427-361-501	>	52-427-285-501	>
3-943-9	Stuff Box Spirol Pin	2	302 Stainless Steel	CP-671-181-371	CP-671-181-371	>	>	>
3-009-9	Shaft Sleeve	2	Bronze	52-239-536-501	52-239-534-501	>	52-239-536-501	>
3-009-9	Shaft Sleeve	2	316 Stainless Steel	52-239-536-504	52-239-534-504	>	52-239-536-504	>
3-009-9	Shaft Sleeve	2	420 Stn. Sl. Hardened	52-239-536-502	52-239-534-502	>	52-239-536-502	>
0-944-0	Shaft Sleeve Lock Pin	2	316 Stainless Steel	52-114-088-007	>	>	>	>
3-914-9	Sleeve, O-Ring	2	Rubber	CP-751-531-428	AC0545	>	CP-751-531-428	>
3-015-9	Shaft Nut	2	Bronze	52-128-640-001	52-128-641-001	>	52-128-640-001	>
3-015-9	Shaft Nut	2	Nitronic 60	52-128-640-002	52-128-641-002	>	52-128-640-002	>
3-902-3	Shaft Nut Setscrew	2	316 Stainless Steel	CP-617-039-367	>	>	>	>
3-007-0	Shaft	1	1045 Steel	52-239-345-001	52-239-343-001	>	52-239-345-001	>
3-007-0	Shaft	1	316 Stainless Steel	52-239-345-002	52-239-343-002	>	52-239-345-002	>
3-007-0	Shaft	1	4140 Steel	52-239-345-003	52-239-343-003	>	52-239-345-003	>
1-924-9	Packing	10	Graphite Acrylic Yarn	AC6128	52-328-740-222	>	AC6128	>
1-014-9	Gland	2	Bronze	52-224-259-501	08-104-772-501	>	52-224-259-501	>
1-904-9	Gland Screw	4	Steel	H28100	P01260	>	H28100	>
1-909-9	Gland Washer	4	Steel	CP-651-001-214	AC1502	>	CP-651-001-214	>
1-013-9	Seal Cage (Optional)	2	Teflon	52-430-298-017	52-430-298-028	>	52-430-298-017	>
0-952-0	Seal Piping Parts (Optional)	1	Plastic	52-127-292-501	>	>	>	>
0-952-0	Seal Piping Parts (Optional)	1	Copper	52-127-292-502	>	>	>	>
Model 150 Standard Coupling Selection. See Pages 33 and 34.								
ANSI/OSHA Coupling & Bracket Kit Selection Charts. See Page 35.								
<b>DIAMETER OF IMPELLER LISTED</b>				<b>12.80"</b>	<b>12.80"</b>	<b>12.80"</b>	<b>13.40"</b>	<b>13.40"</b>
0-002-0	Imp. Assy. (Small Cap)		Bronze	52-238-621-501	N/A	N/A	N/A	N/A
0-002-0	Imp. Assy. (Med. Cap)		Bronze	N/A	N/A	52-236-592-501	N/A	N/A
0-002-0	Imp. Assy. (Lrg. Cap)		Bronze	52-220-846-501	N/A	N/A	N/A	N/A
0-002-0	Imp. Assy. (XL. Cap)		Bronze	N/A	N/A	N/A	52-260-231-501	52-260-231-501
0-004-0	Imp. Wear Ring		Bronze	52-115-029-001	N/A	52-126-810-001	N/A	52-260-227-001
4-002-0	Impeller (Small Cap)		Bronze	52-117-327-001	N/A	N/A	N/A	N/A
4-002-0	Impeller (Med. Cap)		Bronze	N/A	52-122-249-001	N/A	N/A	N/A
4-002-0	Impeller (Lrg. Cap)		Bronze	52-322-152-000	N/A	N/A	N/A	N/A
4-002-0	Impeller (XL Cap)		Bronze	N/A	N/A	N/A	52-360-234-001	N/A

Factory Recommended Spare Parts

Note: Part sheets valid for pumps manufactured after June 1999. Serial number must be provided for pumps manufactured prior to this date.

**PACKING OVER SHAFT SLEEVE**

CAT. NO.	PART DESCRIPTION	QTY.	MATERIAL	6x8x13	6x8x17M,L	8x8x12	8x8x17	8x10x12S,L
2-001-0	Casing	1	Cast Iron	52-118-401-501	52-116-921-501	52-116-968-501	52-116-922-501	52-116-923-501
2-123-5	Casing Gasket-Suct.	1	Vellumoid	52-122-059-005	52-122-061-005	52-122-063-005	52-122-065-005	52-122-067-005
2-123-6	Casing Gasket-Disch.	1	Vellumoid	52-122-060-005	52-122-062-005	52-122-064-005	52-122-066-005	52-122-068-005
2-904-1	Capscrew		Hardened Steel	CP-611-314-615	>	>	CP-611-314-615	>
2-904-1	Capscrew		Hardened Steel	J92017	>	>	>	>
2-916-1	Casing Taper Pin	2	Steel	CP-671-139-491	>	>	>	>
3-003-9	Casing Ring Assy.	2	Bronze	08-104-599-507	08-104-599-510	08-104-599-501	08-104-599-507	08-104-599-501
3-003-9	Casing Ring Assy.	2	Cast Iron	08-104-599-508	08-104-599-511	08-104-599-503	08-104-599-508	08-104-599-503
3-003-9	Casing Ring Assy.	2	Nitronic 60	52-127-084-505	52-127-084-506	52-127-084-507	52-127-084-505	52-127-084-507
3-943-9	Casing Ring, Spirol Pin	2	302 Stainless Steel	CP-671-181-371	>	>	>	>
3-914-2	Casing Ring – O-Ring	1	Rubber	CP-751-531-940	CP-751-531-939	CP-751-531-944	CP-751-531-940	CP-751-531-944
3-914-1	Stuff Box – O-Ring	1	Rubber	CP-751-531-268	>	>	CP-751-531-270	>
3-911-2	Coupling Key	1	Steel	CP-677-103-191	>	>	CP-677-103-238	>
3-911-1	Impeller Key	1	Steel	CP-677-051-153	>	>	CP-677-051-246	>
3-025-3	Brg. House (Inb.)	1	Cast Iron	52-239-566-001	>	>	52-239-570-001	>
3-025-4	Brg. House (Outb.)	1	Cast Iron	52-239-567-001	>	>	52-239-571-001	>
3-026-3	Bearing (Inb.)	1	Steel	CP-811-005-293	>	>	52-113-301-009	>
3-026-4	Bearing (Outb.)	1	Steel	CP-811-443-269	>	>	CP-811-443-295	>
3-516-4	Locknut, Brg.	1	Steel	CP-819-111-207	>	>	CP-819-111-208	>
3-517-4	Lockwasher, Brg.	1	Steel	CP-819-133-207	>	>	CP-819-133-208	>
3-177-9	Lip Seal	2	Rubber & Steel	CP-753-030-907	>	>	CP-753-383-021	>
3-136-9	Deflector	2	Rubber & Steel	52-108-475-009	>	>	52-108-475-011	>
3-904-9	Brg. Hsg. Screw (Inb.)	2	Steel	CP-611-271-482	>	>	>	>
3-904-9	Brg. Hsg. Screw (Outb.)	2	Steel	CP-611-271-484	>	>	>	>
3-073-9	Stuff Box Assy.	2	Cast Iron	52-427-242-501	>	>	52-427-144-501	>
3-943-9	Stuff Box Spirol Pin	2	302 Stainless Steel	CP-671-181-309	>	>	CP-671-181-309	>
3-009-9	Shaft Sleeve	2	Bronze	52-239-534-501	>	>	52-239-538-501	>
3-009-9	Shaft Sleeve	2	316 Stainless Steel	52-239-534-504	>	>	52-239-538-504	>
3-009-9	Shaft Sleeve	2	420 Stn. Stl. Hardened	52-239-534-502	>	>	52-239-538-502	>
0-944-0	Shaft Sleeve Lock Pin	2	316 Stainless Steel	52-114-088-007	>	>	>	>
3-914-9	Sleeve, O-Ring	2	Rubber	AC0545	>	>	CP-751-531-442	>
3-015-9	Shaft Nut	2	Bronze	52-128-641-001	>	>	52-128-642-001	>
3-015-9	Shaft Nut	2	Nitronic 60	52-128-641-002	>	>	52-128-642-002	>
3-902-3	Shaft Nut Setscrew	2	316 Stainless Steel	CP-617-039-366	>	>	>	>
3-007-0	Shaft	1	1045 Steel	52-239-347-001	>	>	52-239-349-001	>
3-007-0	Shaft	1	316 Stainless Steel	52-239-347-002	>	>	52-239-349-002	>
3-007-0	Shaft	1	4140 Steel	N/A	N/A	N/A	52-239-349-003	>
1-924-9	Packing	10	Graphite Acrylic Yarn	AC6129	>	>	AC6130	>
1-014-9	Gland	2	Bronze	08-104-772-501	>	>	08-104-771-501	>
1-904-9	Gland Screw	4	Steel	P01260	>	>	>	>
1-909-9	Gland Washer	4	Steel	AC1502	>	>	>	>
1-013-9	Seal Cage (Optional)	2	Teflon	52-430-298-028	>	>	52-430-298-027	>
0-952-0	Seal Piping Parts (Optional)	1	Plastic	52-127-292-501	>	>	>	>
0-952-0	Seal Piping Parts (Optional)	1	Copper	52-127-292-502	>	>	>	>
Model 150 Standard Coupling Selection. See Pages 33 and 34.								
ANSI/OSHA Coupling & Bracket Kit Selection Charts. See Page 35.								
DIAMETER OF IMPELLER LISTED				13.10"	17.10"	12.80"	17.70"	12.80"
0-002-0	Imp. Assy. (Small Cap)		Bronze	N/A	N/A	N/A	N/A	52-220-877-501
0-002-0	Imp. Assy. (Med. Cap)		Bronze	52-220-825-564	52-225-078-501	52-220-692-501	52-220-784-559	N/A
0-002-0	Imp. Assy. (Lrg. Cap)		Bronze	N/A	52-220-693-506	N/A	N/A	52-221-827-501
0-004-0	Imp. Wear Ring		Bronze	08-982-211-002	08-978-606-001	08-996-357-004	08-982-211-002	08-107-221-001
4-002-0	Impeller (Small Cap)		Bronze	N/A	N/A	N/A	N/A	08-105-840-001
4-002-0	Impeller (Med. Cap)		Bronze	08-105-173-065	52-117-099-001	08-105-084-001	08-105-687-059	N/A
4-002-0	Impeller (Lrg. Cap)		Bronze	N/A	08-105-900-006	N/A	N/A	52-115-223-001

Factory Recommended Spare Parts

Note: Part sheets valid for pumps manufactured after June 1999. Serial number must be provided for pumps manufactured prior to this date.

**PACKING OVER SHAFT SLEEVE**

CAT. NO.	PART DESCRIPTION	QTY.	MATERIAL	8x10x17S,L	8x10x20S,L	10x10x12	10x12x12M
2-001-0	Casing	1	Cast Iron	52-116-924-501	52-128-321-501	52-116-925-501	52-116-926-501
2-123-5	Casing Gasket-Suct.	1	Vellumoid	52-122-069-005	52-239-078-005	52-122-071-005	52-122-073-005
2-123-6	Casing Gasket-Disch.	1	Vellumoid	52-122-070-005	52-239-077-005	52-122-072-005	52-122-074-005
2-904-1	Capscrew		Hardened Steel	CP-611-314-613	>	>	N/A
2-904-1	Capscrew		Hardened Steel	CP-611-314-615	>	>	>
2-904-1	Capscrew		Hardened Steel	CP-611-314-618	>	>	>
2-916-1	Casing Taper Pin	2	Steel	CP-671-139-491	>	>	>
3-003-9	Casing Ring Assy.	2	Bronze	08-104-599-501	52-328-631-501	08-104-599-504	08-104-599-518
3-003-9	Casing Ring Assy.	2	Cast Iron	08-104-599-503	52-328-631-504	08-104-599-505	08-104-599-519
3-003-9	Casing Ring Assy.	2	Nitronic 60	52-127-084-507	52-328-631-505	52-127-084-508	52-127-084-509
3-943-9	Casing Ring, Spirol Pin	2	302 Stainless Steel	CP-671-181-371	>	>	>
3-914-2	Casing Ring – O-Ring	1	Rubber	CP-751-531-944	CP-751-531-949	CP-751-531-949	CP-751-531-991
3-914-1	Stuff Box – O-Ring	1	Rubber	CP-751-531-270	>	>	>
3-911-2	Coupling Key	1	Steel	CP-677-103-238	>	>	>
3-911-1	Impeller Key	1	Steel	CP-677-051-246	>	>	>
3-025-3	Brg. House (Inb.)	1	Cast Iron	52-239-570-001	>	>	>
3-025-4	Brg. House (Outb.)	1	Cast Iron	52-239-571-001	>	>	>
3-026-3	Bearing (Inb.)	1	Steel	52-113-301-009	>	>	>
3-026-4	Bearing (Outb.)	1	Steel	CP-811-443-295	>	>	>
3-516-4	Locknut, Brg.	1	Steel	CP-819-111-208	>	>	>
3-517-4	Lockwasher, Brg.	1	Steel	CP-819-133-208	>	>	>
3-177-9	Lip Seal	2	Rubber & Steel	CP-753-383-021	>	>	>
3-136-9	Deflector	2	Rubber & Steel	52-108-475-011	>	>	>
3-904-9	Brg. Hsg. Screw (Inb.)	2	Steel	CP-611-271-482	>	>	>
3-904-9	Brg. Hsg. Screw (Outb.)	2	Steel	CP-611-271-484	>	>	>
3-073-9	Stuff Box Assy.	2	Cast Iron	52-427-144-501	>	>	>
3-943-9	Stuff Box Spirol Pin	2	Stainless Steel	CP-671-181-309	>	>	>
3-009-9	Shaft Sleeve	2	Bronze	52-239-538-501	>	52-239-540-501	>
3-009-9	Shaft Sleeve	2	316 Stainless Steel	52-239-538-504	>	52-239-540-504	>
3-009-9	Shaft Sleeve	2	420 Stn. Stl. Hardened	52-239-538-502	>	52-239-540-502	>
0-944-0	Shaft Sleeve Lock Pin	2	316 Stainless Steel	52-114-088-007	>	>	>
3-914-9	Sleeve, O-Ring	2	Rubber	CP-751-531-442	>	>	>
3-015-9	Shaft Nut	2	Bronze	52-128-642-001	>	>	>
3-015-9	Shaft Nut	2	Nitronic 60	52-128-642-002	>	>	>
3-902-3	Shaft Nut Setscrew	2	316 Stainless Steel	CP-617-039-367	>	>	>
3-007-0	Shaft	1	1045 Steel	52-239-349-001	>	52-239-351-001	>
3-007-0	Shaft	1	316 Stainless Steel	52-239-349-002	>	52-239-351-002	>
3-007-0	Shaft	1	4140 Steel	52-239-349-003	>	N/A	>
1-924-9	Packing	10	Graphite Acrylic Yarn	AC6130	>	>	>
1-014-9	Gland	2	Bronze	08-104-771-501	>	>	>
1-904-9	Gland Screw	4	Steel	P01260	>	>	>
1-909-9	Gland Washer	4	Steel	AC1502	>	>	>
1-013-9	Seal Cage (Optional)	2	Teflon	52-430-298-027	>	>	>
0-952-0	Seal Piping Parts (Optional)	1	Plastic	52-127-292-501	>	>	>
0-952-0	Seal Piping Parts (Optional)	1	Copper	52-127-292-502	>	>	>
Model 150 Standard Coupling Selection. See Pages 33 and 34.							
ANSI/OSHA Coupling & Bracket Kit Selection Charts. See Page 35.							
<b>DIAMETER OF IMPELLER LISTED</b>				<b>S - 17.70" / L - 17.30"</b>	<b>20.20"</b>	<b>12.80"</b>	<b>12.80"</b>
0-002-0	Imp. Assy. (Small Cap)		Bronze	52-220-811-564	52-327-903-501	N/A	N/A
0-002-0	Imp. Assy. (Med. Cap)		Bronze	N/A	N/A	52-220-756-501	52-220-756-501
0-002-0	Imp. Assy. (Large Cap)		Bronze	52-225-622-501	52-327-907-501	N/A	N/A
0-004-0	Imp. Wear Ring		Bronze	08-996-357-004	08-999-049-002	08-999-049-002	08-975-994-001
4-002-0	Impeller (Small Cap)		Bronze	08-105-085-057	52-327-901-001	N/A	N/A
4-002-0	Impeller (Med. Cap)		Bronze	N/A	N/A	08-105-316-001	08-105-924-053
4-002-0	Impeller (Lrg. Cap)		Bronze	52-322-941-001	52-327-909-001	N/A	N/A

Factory Recommended Spare Parts

Note: Part sheets valid for pumps manufactured after June 1999. Serial number must be provided for pumps manufactured prior to this date.



**PACKING OVER SHAFT SLEEVE**

CAT. NO.	PART DESCRIPTION	QTY.	MATERIAL	10x12x12XL IMP. ONLY	10x12x12XL IMP. ASSY. ONLY	10x12x14	10x12x17
2-001-0	Casing	1	Cast Iron	52-116-926-501	52-129-590-501	52-128-803-501	>
2-123-5	Casing Gasket-Suct.	1	Vellumoid	52-122-073-005	>	52-128-806-005	>
2-123-6	Casing Gasket-Disch.	1	Vellumoid	52-122-074-005	>	52-128-805-005	>
2-904-1	Capscrew		Hardened Steel	N/A	N/A	CP-611-314-613	>
2-904-1	Capscrew		Hardened Steel	CP-611-314-615	>	>	>
2-904-1	Capscrew		Hardened Steel	CP-611-314-618	>	CP-617-511-691	>
2-916-1	Casing Taper Pin	2	Steel	CP-671-139-491	>	>	>
3-003-9	Casing Ring Assy.	2	Bronze	08-104-599-518	52-260-234-501	08-104-599-504	>
3-003-9	Casing Ring Assy.	2	Cast Iron	08-104-599-519	N/A	08-104-599-505	>
3-003-9	Casing Ring Assy.	2	Nitronic 60	52-127-084-509	52-260-234-502	52-127-084-508	>
3-943-9	Casing Ring, Spirol Pin	2	302 Stainless Steel	CP-671-181-371	>	>	>
3-914-2	Casing Ring - O-Ring	1	Rubber	CP-751-531-991	>	CP-751-531-949	>
3-914-1	Stuff Box - O-Ring	1	Rubber	CP-751-531-270	>	CP-751-531-270	>
3-911-2	Coupling Key	1	Steel	CP-677-103-238	>	>	>
3-911-1	Impeller Key	1	Steel	CP-677-051-246	>	>	>
3-025-3	Brg. House (Inb.)	1	Cast Iron	52-239-570-001	>	>	>
3-025-4	Brg. House (Outb.)	1	Cast Iron	52-239-571-001	>	>	>
3-026-3	Bearing (Inb.)	1	Steel	52-113-301-009	>	>	>
3-026-4	Bearing (Outb.)	1	Steel	CP-811-443-295	>	>	>
3-516-4	Locknut, Brg.	1	Steel	CP-819-111-208	>	>	>
3-517-4	Lockwasher, Brg.	1	Steel	CP-819-133-208	>	>	>
3-177-9	Lip Seal	2	Rubber & Steel	CP-753-383-021	>	>	>
3-136-9	Deflector	2	Rubber & Steel	52-108-475-011	>	>	>
3-904-9	Brg. Hsg. Screw (Inb.)	2	Steel	CP-611-271-482	>	>	>
3-904-9	Brg. Hsg. Screw (Outb.)	2	Steel	CP-611-271-484	>	>	>
3-073-9	Stuff Box Assy.	2	Cast Iron	52-427-144-501	>	>	>
3-943-9	Stuff Box Spirol Pin	2	302 Stainless Steel	CP-671-181-309	>	>	>
3-009-9	Shaft Sleeve	2	Bronze	52-239-540-501	>	52-239-538-501	>
3-009-9	Shaft Sleeve	2	316 Stainless Steel	52-239-540-504	>	52-239-538-504	>
3-009-9	Shaft Sleeve	2	420 Stn. Sil. Hardened	52-239-540-502	>	52-239-538-502	>
0-944-0	Shaft Sleeve Lock Pin	2	316 Stainless Steel	52-114-088-007	>	>	>
3-914-9	Sleeve, O-Ring	2	Rubber	CP-751-531-442	>	>	>
3-015-9	Shaft Nut	2	Bronze	52-128-642-001	>	>	>
3-015-9	Shaft Nut	2	Nitronic 60	52-128-642-002	>	>	>
3-902-3	Shaft Nut Setscrew	2	316 Stainless Steel	CP-617-039-367	>	>	>
3-007-0	Shaft	1	1045 Steel	52-239-351-001	>	52-239-349-001	>
3-007-0	Shaft	1	316 Stainless Steel	52-239-351-002	>	52-239-349-002	>
1-924-9	Packing	10	Graphite Acrylic Yarn	AC6130	>	>	>
1-014-9	Gland	2	Bronze	08-104-771-501	>	>	>
1-904-9	Gland Screw	4	Steel	P01260	>	>	>
1-909-9	Gland Washer	4	Steel	AC1502	>	>	>
1-013-9	Seal Cage (Optional)	2	Teflon	52-430-298-027	>	>	>
0-952-0	Seal Piping Parts (Optional)	1	Plastic	52-127-292-501	>	>	>
0-952-0	Seal Piping Parts (Optional)	1	Copper	52-127-292-502	>	>	>
	Model 150 Standard Coupling Selection. See Pages 33 and 34.						
	ANSI/OSHA Coupling & Bracket Kit Selection Charts. See Pages 35.						
<b>DIAMETER OF IMPELLER LISTED</b>				<b>13.50"</b>	<b>13.50"</b>	<b>14.00"</b>	<b>17.50"</b>
0-002-0	Imp. Assy. (Med. Cap)		Bronze	N/A	N/A	52-225-036-501	52-220-694-501
0-002-0	Imp. Assy. (XL Cap)		Bronze	N/A	52-260-488-501	N/A	N/A
0-004-0	Imp. Wear Ring		Bronze	N/A	N/A	08-999-049-002	N/A
4-002-0	Impeller (Med. Cap)		Bronze	N/A	N/A	08-116-699-001	08-105-086-001

Factory Recommended Spare Parts

Note: Part sheets valid for pumps manufactured after June 1999. Serial number must be provided for pumps manufactured prior to this date.

## MECHANICAL SEAL OVER SHAFT SLEEVE

### INDEX

PAGE	DESCRIPTION
11	Mechanical Seal Over Shaft Sleeve Exploded View
12	2x3x11S&L, 4X6X10a, 4x6x10M
13	4x6x12A, 4x6x14A, 4x6x14L
14	6x8x12S&L, 6x8x12M, 6x8x12XL
15	6x8x13, 6x8x17M&L, 8x8x12, 8x8x17, 8x10x12S&L
16	8x10x17S&L, 8x10x20S&L, 10x10x12, 10x12x12M
17	10x12x12XL, 10x12x14, 10x12x17
	<b>Conversion Tables</b>
28	Mech. Seal Over Sleeve to Packing
30-31	Series 150 Standard EDPM Coupling Selection
32	ANSI/OSHA Coupling & Bracket Kit Selection Charts

### FRAME DESIGNATION

PUMP SIZE	FRAME	PUMP SIZE	FRAME
2x3x11S&L	F20-A6	6x8x17M&L	F20-D6
4x6x10A	F20-C6	8x8x12	F20-D6
4x6x10M	F20-B6	8x8x17	F20-E6
4x6x12A	F20-B6	8x10x12S&L	F20-E6
4x6x14A,L	F20-C6	8x10x17S&L	F20-E6
6x8x10A	F20-I6	8x10x20S&L	F20-E6
6x8x12S&L	F20-C6	10x10x12	F20-F6
6x8x12XL	F20-C6	10x12x12M&XL	F20-F6
6x8x12M	F20-B6	10x12x14	F20-E6
6x8x13	F20-D6	10x12x17	F20-E6

# MECHANICAL SEAL OVER SHAFT SLEEVE

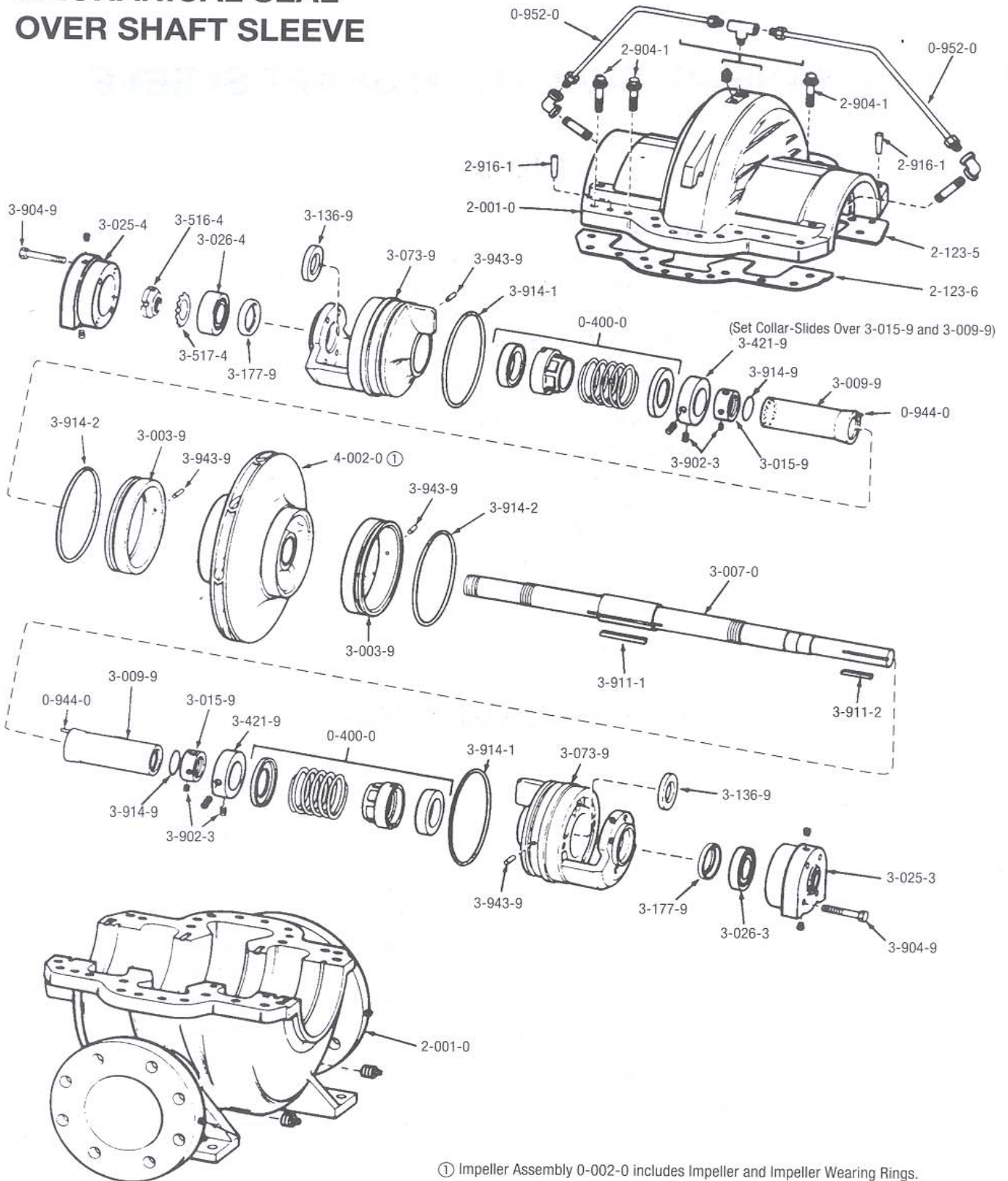

① Impeller Assembly 0-002-0 includes Impeller and Impeller Wearing Rings.

**MECHANICAL SEAL OVER SHAFT SLEEVE**

CAT. NO.	PART DESCRIPTION	QTY.	MATERIAL	2x3x11S,L	4x6x10A	4x6x10M IMP. ONLY	4x6x10M IMP. ASSY. ONLY
2-001-0	Casing	1	Cast Iron	52-116-916-501	52-460-745-501	52-116-917-501	52-116-917-511
2-123-5	Casing Gasket-Suct.	1	Vellumoid	52-117-348-005	52-260-249-005	52-117-415-005	>
2-123-6	Casing Gasket Disch.	1	Vellumoid	52-117-347-005	52-260-248-005	52-117-414-005	>
2-904-1	Capscrew		Hardened Steel	CP-611-314-613	CP-611-314-615	CP-611-314-613	>
2-904-1	Capscrew		Hardened Steel	N/A	CP-611-314-618	CP-611-314-617	>
2-904-1	Capscrew		Hardened Steel	CP-611-314-616	J92017	>	>
2-916-1	Casing Taper Pin	2	Steel	CP-671-139-491	>	>	>
3-003-9	Casing Ring Assy.	2	Bronze	52-117-232-501	52-117-118-501	52-117-418-501	52-117-118-501
3-003-9	Casing Ring Assy.	2	Cast Iron	52-117-232-502	52-117-118-502	52-117-418-502	52-117-118-502
3-003-9	Casing Ring Assy.	2	Nitronic 60	52-127-084-501	52-127-084-503	52-127-084-502	52-127-084-503
3-943-9	Cas. Ring, Spirol Pin	2	302 Stainless Steel	CP-671-181-371	52-105-715-020	CP-671-181-371	>
3-914-2	Casing Ring – O-Ring	2	Rubber	CP-751-531-924	CP-751-531-932	CP-751-561-028	CP-751-531-932
3-914-1	Stuff Box – O-Ring	2	Rubber	CP-751-531-954	CP-751-531-264	>	>
3-911-2	Coupling Key	1	Steel	AC0522	>	CP-677-103-191	>
3-911-1	Impeller Key	1	Steel	CP-677-103-183	>	CP-677-051-146	>
3-025-3	Brg. House (Inb.)	1	Cast Iron	52-239-562-001	52-239-562-001	>	>
3-025-4	Brg. House (Outb.)	1	Cast Iron	52-239-563-001	>	52-239-563-001	>
3-026-3	Bearing (Inb.)	1	Steel	52-113-300-006	>	CP-811-005-293	>
3-026-4	Bearing (Outb.)	1	Steel	CP-811-443-227	>	CP-811-443-269	>
3-516-4	Locknut, Brg.	1	Steel	CP-819-111-206	>	CP-819-111-207	>
3-517-4	Lockwasher, Brg.	1	Steel	CP-819-133-206	>	CP-819-133-207	>
3-177-9	Lip Seal	2	Rubber & Steel	CP-753-030-535	>	CP-753-030-907	>
3-136-9	Deflector	2	Rubber & Steel	52-117-840-002	>	52-108-475-009	>
3-904-9	Brg. Hsg. Screw (Inb.)	2	Steel	DJ0081	>	CP-611-271-482	>
3-904-9	Brg. Hsg. Screw (Outb.)	2	Steel	CP-611-271-482	>	CP-611-271-484	>
3-073-9	Stuff Box Assy.	2	Cast Iron	52-427-742-501	AC8437/AC8438	52-427-757-501	>
3-943-9	Stuff Box Spirol Pin	2	302 Stainless Steel	CP-671-181-371	>	>	>
3-009-9	Shaft Sleeve	2	Bronze	52-239-532-501	52-239-536-501	52-239-534-501	>
3-009-9	Shaft Sleeve	2	316 Stainless Steel	52-239-532-504	52-239-536-504	52-239-534-504	>
0-944-0	Shaft Sleeve Lock Pin	2	316 Stainless Steel	52-114-088-007	>	>	>
3-914-9	Sleeve, O-Ring	2	Rubber	CP-751-531-428	>	AC0545	>
3-015-9	Shaft Nut	2	Bronze	52-128-640-001	>	52-128-641-001	>
3-015-9	Shaft Nut	2	Nitronic 60	52-128-640-002	>	52-128-641-002	>
3-902-3	Shaft Nut Setscrew	2	316 Stainless Steel	CP-617-039-367	CP-617-039-366	CP-617-039-367	>
3-007-0	Shaft	1	1045 Steel	52-239-341-001	52-360-245-001	52-239-343-001	>
3-007-0	Shaft	1	316 Stainless Steel	52-239-341-002	52-360-245-002	52-239-343-002	>
3-007-0	Shaft	1	4140 Steel	52-239-341-003	52-360-245-003	52-239-343-003	>
0-400-0	Mech. Seal	2	BF <sub>50</sub> TO <sub>10</sub> T Type 21	52-122-693-805	>	>	>
3-421-9	Set Collar	2	Bronze	52-114-034-030	52-114-034-035	52-114-034-030	>
3-902-3	Set Screw-Set Collar	2	316 Stainless Steel	CP-617-059-369	>	>	>
0-952-0	Seal Piping Parts	1	Plastic	52-127-292-503	>	>	>
0-952-0	Seal Piping Parts	1	Copper	52-127-292-504	>	>	>
Model 150 Standard EPDM Coupling Selection. See Pages 33 and 34.							
ANSI/OSHA Coupling & Bracket Kit Selection Charts. See Page 35.							
<b>DIAMETER OF IMPELLER LISTED</b>				<b>11.00"</b>	<b>9.80"</b>	<b>S,L -11.00"/ M -12.00"</b>	<b>12.00"</b>
0-002-0	Imp. Assy. (Small Cap)		Bronze	52-235-591-501	N/A	52-225-402-501	N/A
0-002-0	Imp. Assy. (Med. Cap)		Bronze	N/A	N/A	N/A	52-235-812-501
0-002-0	Imp. Assy. (Lrg. Cap)		Bronze	52-225-401-501	N/A	52-225-403-501	N/A
0-004-0	Imp. Wear Ring		Bronze	08-998-120-001	N/A	08-975-856-001	08-998-246-001
4-002-0	Impeller (Small Cap)		Bronze	52-235-573-001	N/A	52-117-268-001	N/A
4-002-0	Impeller (Med. Cap)		Bronze	N/A	N/A	52-233-459-001	N/A
4-002-0	Impeller (Lrg. Cap)		Bronze	52-117-447-110	AC2699	52-117-343-001	N/A

Factory Recommended Spare Parts

Note: Part sheets valid for pumps manufactured after June 1999. Serial number must be provided for pumps manufactured prior to this date.

**MECHANICAL SEAL OVER SHAFT SLEEVE**

CAT. NO.	PART DESCRIPTION	QTY.	MATERIAL	4x6x12A	4x6x14A	4x6x14L
2-001-0	Casing	1	Cast Iron	52-116-917-511	52-129-588-501	52-116-919-501
2-123-5	Casing Gasket-Suct.	1	Vellumoid	52-117-415-005	52-111-314-005	52-117-366-005
2-123-6	Casing Gasket Disch.	1	Vellumoid	52-117-414-005	52-111-315-005	52-117-367-005
2-904-1	Capscrew		Hardened Steel	CP-611-314-615	>	CP-611-314-613
2-904-1	Capscrew		Hardened Steel	CP-611-314-618	N/A	J92017
2-916-1	Casing Taper Pin	2	Steel	CP-671-139-491	>	>
3-003-9	Casing Ring Assy.	2	Bronze	52-117-118-501	52-260-233-501	52-117-118-501
3-003-9	Casing Ring Assy.	2	Cast Iron	52-117-118-502	52-260-233-502	52-117-118-502
3-003-9	Casing Ring Assy.	2	Nitronic 60	52-127-084-503	N/A	52-127-084-503
3-943-9	Casing Ring, Spirol Pin	2	302 Stainless Steel	52-105-715-020	>	>
3-914-2	Casing Ring - O-Ring	2	Rubber	CP-751-531-932	CP-751-531-934	CP-751-531-932
3-914-1	Stuff Box - O-Ring	2	Rubber	CP-751-531-264	>	>
3-911-2	Coupling Key	1	Steel	CP-677-103-191	AC0522	>
3-911-1	Impeller Key	1	Steel	CP-677-051-146	CP-677-103-183	>
3-025-3	Brg. House (Inb.)	1	Cast Iron	52-239-562-001	>	>
3-025-4	Brg. House (Outb.)	1	Cast Iron	52-239-563-001	>	>
3-026-3	Bearing (Inb.)	1	Steel	52-113-300-006	>	>
3-026-4	Bearing (Outb.)	1	Steel	CP-811-443-227	>	>
3-516-4	Locknut, Brg.	1	Steel	CP-819-111-206	>	>
3-517-4	Lockwasher, Brg.	1	Steel	CP-819-133-206	>	>
3-177-9	Lip Seal	2	Rubber & Steel	CP-753-030-535	>	>
3-136-9	Deflector	2	Rubber & Steel	52-117-840-002	>	>
3-904-9	Brg. Hsg. Screw (Inb.)	2	Steel	DJ0081	>	>
3-904-9	Brg. Hsg. Screw (Outb.)	2	Steel	CP-611-271-482	>	>
3-073-9	Stuff Box Assy.	2	Cast Iron	52-427-757-501	52-427-741-501	>
3-943-9	Stuff Box Spirol Pin	2	302 Stainless Steel	CP-671-181-371	>	>
3-009-9	Shaft Sleeve	2	Bronze	52-239-535-501	>	>
3-009-9	Shaft Sleeve	2	316 Stainless Steel	52-239-536-504	>	>
0-944-0	Shaft Sleeve Lock Pin	2	316 Stainless Steel	52-114-088-007	>	>
3-914-9	Sleeve, O-Ring	2	Rubber	CP-751-531-428	>	>
3-015-9	Shaft Nut	2	Bronze	52-128-641-001	>	>
3-015-9	Shaft Nut	2	Nitronic 60	52-128-640-002	>	>
3-902-3	Shaft Nut Setscrew	2	316 Stainless Steel	CP-617-039-367	CP-617-039-366	CP-617-039-367
3-007-0	Shaft	1	1045 Steel	52-239-343-001	52-239-345-001	>
3-007-0	Shaft	1	316 Stainless Steel	52-239-343-002	52-239-345-002	>
3-007-0	Shaft	1	4140 Steel	52-239-343-003	52-239-345-003	N/A
0-400-0	Mech. Seal	2	BF <sub>50</sub> T0 <sub>10</sub> 1 Type 21	52-122-693-804	52-122-693-805	>
3-421-9	Set Collar	2	Bronze	52-114-034-037	52-114-034-035	52-114-034-030
3-902-3	Set Screw-Set Collar	2	316 Stainless Steel	CP-617-039-369	>	>
0-952-0	Seal Piping Parts	1	Plastic	52-127-292-503	>	>
0-952-0	Seal Piping Parts	1	Copper	52-127-292-504	>	>
Model 150 Standard EPDM Coupling Selection. See Pages 33 and 34.						
ANSI/OSHA Coupling & Bracket Kit Selection Charts. See Page 35.						
<b>DIAMETER OF IMPELLER LISTED</b>				<b>12.00"</b>	<b>13.80"</b>	<b>13.80"</b>
0-002-0	Imp. Assy. (Small Cap)		Bronze	N/A	N/A	52-225-190-501
0-002-0	Imp. Assy. (Lrg. Cap)		Bronze	N/A	N/A	52-225-405-501
0-004-0	Imp. Wear Ring		Bronze	N/A	N/A	08-998-246-001
4-002-0	Impeller (Small Cap)		Bronze	N/A	N/A	52-117-222-001
4-002-0	Impeller (Lrg. Cap)		Bronze	AC8447	AC8449	52-117-374-001

Factory Recommended Spare Parts

Note: Part sheets valid for pumps manufactured after June 1999. Serial number must be provided for pumps manufactured prior to this date.

## MECHANICAL SEAL OVER SHAFT SLEEVE

CAT. NO.	PART DESCRIPTION	QTY.	MATERIAL	6x8x12S,L	6x8x12M IMP. ONLY	6x8x12M IMP. ASSY. ONLY	6x8x12XL IMP. ONLY	6x8x12XL IMP. ASSY. ONLY
2-001-0	Casing	1	Cast Iron	52-116-920-501	>	52-116-920-514	52-116-920-501	52-116-920-514
2-123-5	Casing Gasket-Suct.	1	Vellumoid	52-111-310-005	>	>	>	>
2-123-6	Casing Gasket Disch.	1	Vellumoid	52-111-311-005	>	>	>	>
2-904-1	Capscrew		Hardened Steel	CP-611-314-615	>	>	>	>
2-904-1	Capscrew		Hardened Steel	J92017	>	>	>	>
2-916-1	Casing Taper Pin	2	Steel	CP-671-139-491	>	>	>	>
3-003-9	Casing Ring Assy.	2	Bronze	52-117-117-501	>	52-126-809-501	52-117-117-501	52-126-809-501
3-003-9	Casing Ring Assy.	2	Cast Iron	52-118-082-501	>	52-126-809-502	52-118-082-501	52-126-809-502
3-003-9	Casing Ring Assy.	2	Nitronic 60	52-127-084-504	>	52-127-084-510	52-127-084-504	N/A
3-943-9	Casing Ring, Spirol Pin	2	302 Stainless Steel	CP-671-181-371	>	>	>	>
3-914-2	Casing Ring - O-Ring	2	Rubber	CP-751-531-937	>	CP-751-531-938	CP-751-531-937	>
3-914-1	Stuff Box - O-Ring	2	Rubber	CP-751-531-264	>	>	>	>
3-911-2	Coupling Key	1	Steel	AC0522	CP-677-103-191	>	AC0522	>
3-911-1	Impeller Key	1	Steel	CP-677-103-183	CP-677-051-146	>	CP-677-103-183	>
3-025-3	Brg. House (Inb.)	1	Cast Iron	52-239-562-001	52-239-566-001	>	52-239-562-001	>
3-025-4	Brg. House (Outb.)	1	Cast Iron	52-239-563-001	52-239-567-001	>	52-239-563-001	>
3-026-3	Bearing (Inb.)	1	Steel	52-113-300-006	CP-811-005-293	>	52-113-300-006	>
3-026-4	Bearing (Outb.)	1	Steel	CP-811-443-227	CP-811-443-269	>	CP-811-443-227	>
3-516-4	Locknut, Brg.	1	Steel	CP-819-111-206	CP-819-111-207	>	CP-819-111-206	>
3-517-4	Lockwasher, Brg.	1	Steel	CP-819-133-206	CP-819-133-207	>	CP-819-133-206	>
3-177-9	Lip Seal	2	Rubber & Steel	CP-753-030-535	CP-753-030-907	>	CP-753-030-535	>
3-136-9	Deflector	2	Rubber & Steel	52-117-840-002	52-108-475-009	>	52-117-840-002	>
3-904-9	Brg. Hsg. Screw (Inb.)	2	Steel	DJ0081	CP-611-271-482	>	DJ0081	>
3-904-9	Brg. Hsg. Screw (Outb.)	2	Steel	CP-611-271-482	CP-611-271-484	>	CP-611-271-482	>
3-073-9	Stuff Box Assy.	2	Cast Iron	52-427-741-501	52-427-757-501	>	52-427-741-501	>
3-943-9	Stuff Box Spirol Pin	2	302 Stainless Steel	CP-671-181-371	>	>	>	>
3-009-9	Shaft Sleeve	2	Bronze	52-239-536-501	52-239-534-501	>	52-239-536-501	>
3-009-9	Shaft Sleeve	2	316 Stainless Steel	52-239-536-504	52-239-534-504	>	52-239-536-504	>
0-944-0	Shaft Sleeve Lock Pin	2	316 Stainless Steel	52-114-088-007	>	>	>	>
3-914-9	Sleeve, O-Ring	2	Rubber	CP-751-531-428	AC0545	>	CP-751-531-428	>
3-015-9	Shaft Nut	2	Bronze	52-128-640-001	52-128-641-001	>	52-128-640-001	>
3-015-9	Shaft Nut	2	Nitronic 60	52-128-640-002	52-128-641-002	>	52-128-640-002	>
3-902-3	Shaft Nut Setscrew	2	316 Stainless Steel	CP-617-039-367	>	>	>	>
3-007-0	Shaft	1	1045 Steel	52-239-345-001	52-239-343-001	>	52-239-345-001	>
3-007-0	Shaft	1	316 Stainless Steel	52-239-345-002	52-239-343-002	>	52-239-345-002	>
3-007-0	Shaft	1	4140 Steel	52-239-345-003	52-239-343-003	>	52-239-345-003	>
0-400-0	Mech. Seal	2	BF <sub>50</sub> TC <sub>10</sub> Type 21	52-122-693-805	52-122-693-804	>	52-122-693-805	>
3-421-9	Set Collar	2	Bronze	52-114-034-030	52-114-034-029	>	52-114-034-030	>
3-902-3	Set Screw-Set Collar	2	316 Stainless Steel	CP-617-059-369	>	>	>	>
0-952-0	Seal Piping Parts	1	Plastic	52-127-292-503	>	>	>	>
0-952-0	Seal Piping Parts	1	Copper	52-127-292-504	>	>	>	>
Series 150 Standard EPDM Coupling Selection. See Pages 33 and 34.								
ANSI/OSHA Coupling & Bracket Kit Selection Charts. See Page 35.								
DIAMETER OF IMPELLER LISTED				12.80"	12.80"	12.80"	13.40"	13.40"
0-002-0	Imp. Assy. (Small Cap)		Bronze	52-238-621-501	N/A	N/A	N/A	N/A
0-002-0	Imp. Assy. (Med. Cap)		Bronze	N/A	N/A	52-236-592-501	N/A	N/A
0-002-0	Imp. Assy. (Lrg. Cap)		Bronze	52-220-846-501	N/A	N/A	N/A	N/A
0-002-0	Imp. Assy. (XL Cap)		Bronze	N/A	N/A	N/A	N/A	52-260-231-501
0-004-0	Imp. Wear Ring		Bronze	52-115-029-001	N/A	52-126-810-001	N/A	52-260-227-001
4-002-0	Impeller (Small Cap)		Bronze	52-117-327-001	N/A	N/A	N/A	N/A
4-002-0	Impeller (Med. Cap)		Bronze	N/A	52-122-249-001	N/A	N/A	N/A
4-002-0	Impeller (Lrg. Cap)		Bronze	52-322-152-000	N/A	N/A	N/A	N/A
4-002-0	Impeller (XL Cap)		Bronze	N/A	N/A	N/A	52-360-234-001	N/A

Factory Recommended Spare Parts

Note: Part sheets valid for pumps manufactured after June 1999. Serial number must be provided for pumps manufactured prior to this date.

## MECHANICAL SEAL OVER SHAFT SLEEVE

CAT. NO.	PART DESCRIPTION	QTY.	MATERIAL	6x8x13	6x8x17M,L	8x8x12	8x8x17	8x10x12S,L
2-001-0	Casing	1	Cast Iron	52-118-401-501	52-116-921-501	52-116-968-501	52-116-922-501	52-116-923-501
2-123-5	Casing Gasket-Suct.	1	Vellumoid	52-122-059-005	52-122-061-005	52-122-063-005	52-122-065-005	52-122-067-005
2-123-6	Casing Gasket Disch.	1	Vellumoid	52-122-060-005	52-122-062-005	52-122-064-005	52-122-066-005	52-122-068-005
2-904-1	Capscrew		Hardened Steel	CP-611-314-615	>	>	>	>
2-904-1	Capscrew		Hardened Steel	J92017	>	>	>	>
2-916-1	Casing Taper Pin	2	Steel	CP-671-139-491	>	>	>	>
3-003-9	Casing Ring Assy.	2	Bronze	08-104-599-507	08-104-599-510	08-104-599-501	08-104-599-507	08-104-599-501
3-003-9	Casing Ring Assy.	2	Cast Iron	08-104-599-508	08-104-599-511	08-104-599-503	08-104-599-508	08-104-599-503
3-003-9	Casing Ring Assy.	2	Nitronic 60	52-127-084-505	52-127-084-506	52-127-084-507	52-127-084-505	52-127-084-507
3-943-9	Casing Ring, Spirol Pin	2	302 Stainless Steel	CP-671-181-371	>	>	>	>
3-914-2	Casing Ring – O-Ring	2	Rubber	CP-751-531-940	CP-751-531-939	CP-751-531-944	CP-751-531-940	CP-751-531-944
3-914-1	Stuff Box – O-Ring	2	Rubber	CP-751-531-268	>	>	CP-751-531-270	CP-751-531-270
3-911-2	Coupling Key	1	Steel	CP-677-103-191	>	>	CP-677-103-238	CP-671-103-238
3-911-1	Impeller Key	1	Steel	CP-677-051-153	>	>	CP-677-051-246	CP-677-051-246
3-025-3	Brg. House (Inb.)	1	Cast Iron	52-239-566-001	>	>	52-239-570-001	>
3-025-4	Brg. House (Outb.)	1	Cast Iron	52-239-567-001	>	>	52-239-571-001	>
3-026-3	Bearing (Inb.)	1	Steel	CP-811-005-293	>	>	52-113-301-009	>
3-026-4	Bearing (Outb.)	1	Steel	CP-811-443-269	>	>	CP-811-443-295	>
3-516-4	Locknut, Brg.	1	Steel	CP-819-111-207	>	>	CP-819-111-208	>
3-517-4	Lockwasher, Brg.	1	Steel	CP-819-133-207	>	>	CP-819-133-208	>
3-177-9	Lip Seal	2	Rubber & Steel	CP-753-030-907	>	>	CP-753-383-021	>
3-136-9	Deflector	2	Rubber & Steel	52-108-475-009	>	>	52-108-475-011	>
3-904-9	Brg. Hsg. Screw (Inb.)	2	Steel	CP-611-271-482	>	>	>	>
3-904-9	Brg. Hsg. Screw (Outb.)	2	Steel	CP-611-271-484	>	>	>	>
3-073-9	Stuff Box Assy.	2	Cast Iron	52-427-932-501	>	>	52-427-546-501	>
3-943-9	Stuff Box Spirol Pin	2	302 Stainless Steel	CP-671-181-309	>	>	>	>
3-009-9	Shaft Sleeve	2	Bronze	52-239-534-501	>	>	52-239-538-501	>
3-009-9	Shaft Sleeve	2	316 Stainless Steel	52-239-534-504	>	>	52-239-538-504	>
0-944-0	Shaft Sleeve Lock Pin	2	316 Stainless Steel	52-114-088-007	>	>	>	>
3-914-9	Sleeve, O-Ring	2	Rubber	AC0545	>	>	CP-751-531-442	>
3-015-9	Shaft Nut	2	Bronze	52-128-641-001	>	>	52-128-642-001	>
3-015-9	Shaft Nut	2	Nitronic 60	52-128-641-002	>	>	52-128-642-002	>
3-902-3	Shaft Nut Setscrew	2	316 Stainless Steel	CP-617-039-367	>	>	>	>
3-007-0	Shaft	1	1045 Steel	52-239-347-001	>	>	52-239-349-001	>
3-007-0	Shaft	1	316 Stainless Steel	52-239-347-002	>	>	52-239-349-002	>
3-007-0	Shaft	1	4140 Steel	N/A	N/A	N/A	52-239-349-003	>
0-400-0	Mech. Seal	2	BF <sub>50</sub> TO <sub>10</sub> 1 Type 21	52-122-693-804	>	>	52-122-693-806	>
3-421-9	Set Collar	2	Bronze	52-114-034-029	>	>	52-114-034-031	>
3-902-3	Set Screw-Set Collar	2	316 Stainless Steel	CP-617-039-369	>	>	>	>
0-952-0	Seal Piping Parts	1	Plastic	52-117-292-503	>	>	>	>
0-952-0	Seal Piping Parts	1	Copper	52-117-292-504	>	>	>	>
Model 150 Standard EPDM Coupling Selection. See Pages 33 and 34.								
ANSI/OSHA Coupling & Bracket Kit Selection Charts. See Page 35.								
DIAMETER OF IMPELLER LISTED				13.10"	17.70"	12.80"	17.70"	12.80"
0-002-0	Imp. Assy. (Small Cap)		Bronze	N/A	N/A	N/A	N/A	52-220-877-501
0-002-0	Imp. Assy. (Med. Cap)		Bronze	52-220-825-564	52-225-078-501	52-220-692-501	52-220-784-502	N/A
0-002-0	Imp. Assy. (Lrg. Cap)		Bronze	N/A	52-220-693-506	N/A	N/A	52-221-827-501
0-004-0	Imp. Wear Ring		Bronze	08-982-211-002	08-978-606-001	08-996-357-004	08-982-211-002	08-107-221-001
4-002-0	Impeller (Small Cap)		Bronze	N/A	N/A	N/A	N/A	08-105-840-001
4-002-0	Impeller (Med. Cap)		Bronze	08-105-173-065	52-117-099-001	08-105-084-001	08-105-687-059	N/A
4-002-0	Impeller (Lrg. Cap)		Bronze	N/A	08-105-900-006	N/A	N/A	52-115-223-001

Factory Recommended Spare Parts

Note: Part sheets valid for pumps manufactured after June 1999. Serial number must be provided for pumps manufactured prior to this date.

## MECHANICAL SEAL OVER SHAFT SLEEVE

CAT. NO.	PART DESCRIPTION	QTY.	MATERIAL	8x10x17S,L	8x10x20S,L	10x10x12	10x12x12M
2-001-0	Casing	1	Cast Iron	52-116-924-501	52-128-321-501	52-116-925-501	52-116-926-501
2-123-5	Casing Gasket-Suct.	1	Vellumoid	52-122-069-005	52-239-078-005	52-122-071-005	52-122-073-005
2-123-6	Casing Gasket Disch.	1	Vellumoid	52-122-070-005	52-239-077-005	52-122-072-005	52-122-074-005
2-904-1	Capscrew		Hardened Steel	CP-611-314-613	N/A	CP-611-314-613	N/A
2-904-1	Capscrew		Hardened Steel	CP-611-314-615	>	>	>
2-904-1	Capscrew		Hardened Steel	J92017	>	>	>
2-916-1	Casing Taper Pin	2	Steel	CP-671-139-491	>	>	>
3-003-9	Casing Ring Assy.	2	Bronze	08-104-599-501	52-328-631-501	08-104-599-504	08-104-599-518
3-003-9	Casing Ring Assy.	2	Cast Iron	08-104-599-503	52-328-631-504	08-104-599-505	08-104-599-519
3-003-9	Casing Ring Assy.	2	Nitronic 60	52-127-084-507	52-328-631-505	52-127-084-508	52-127-084-509
3-943-9	Casing Ring, Spirol Pin	2	302 Stainless Steel	CP-671-181-371	>	>	>
3-914-2	Casing Ring – O-Ring	2	Rubber	CP-751-531-944	CP-751-531-949	CP-751-531-949	CP-751-531-991
3-914-1	Stuff Box – O-Ring	2	Rubber	CP-751-531-270	>	>	>
3-911-2	Coupling Key	1	Steel	CP-671-103-238	>	>	>
3-911-1	Impeller Key	1	Steel	CP-677-051-246	>	>	>
3-025-3	Brg. House (Inb.)	1	Cast Iron	52-239-570-001	>	>	>
3-025-4	Brg. House (Outb.)	1	Cast Iron	52-239-571-001	>	>	>
3-026-3	Bearing (Inb.)	1	Steel	52-113-301-009	>	>	>
3-026-4	Bearing (Outb.)	1	Steel	CP-811-443-295	>	>	>
3-516-4	Locknut, Brg.	1	Steel	CP-819-111-208	>	>	>
3-517-4	Lockwasher, Brg.	1	Steel	CP-819-133-208	>	>	>
3-177-9	Lip Seal	2	Rubber & Steel	CP-753-383-021	>	>	>
3-136-9	Deflector	2	Rubber & Steel	52-108-475-011	>	>	>
3-904-9	Brg. Hsg. Screw (Inb.)	2	Steel	CP-611-271-482	>	>	>
3-904-9	Brg. Hsg. Screw (Outb.)	2	Steel	CP-611-271-484	>	>	>
3-073-9	Stuff Box Assy.	2	Cast Iron	52-427-546-501	>	>	>
3-943-9	Stuff Box Spirol Pin	2	302 Stainless Steel	CP-671-181-309	>	>	>
3-009-9	Shaft Sleeve	2	Bronze	52-239-538-501	>	52-239-540-501	>
3-009-9	Shaft Sleeve	2	316 Stainless Steel	52-239-538-504	>	52-239-540-504	>
0-944-0	Shaft Sleeve Lock Pin	2	316 Stainless Steel	52-114-088-007	>	>	>
3-914-9	Sleeve, O-Ring	2	Rubber	CP-751-531-442	>	>	>
3-015-9	Shaft Nut	2	Bronze	52-128-642-001	>	>	>
3-015-9	Shaft Nut	2	Nitronic 60	52-128-642-002	>	>	>
3-902-3	Shaft Nut Setscrew	2	316 Stainless Steel	CP-617-039-367	>	>	>
3-007-0	Shaft	1	1045 Steel	52-239-349-001	>	52-239-351-001	>
3-007-0	Shaft	1	316 Stainless Steel	52-239-349-002	>	52-239-351-002	>
3-007-0	Shaft	1	4140 Steel	52-239-349-003	>	N/A	>
0-400-0	Mech. Seal	2	BF <sub>50</sub> 1O <sub>10</sub> 1 Type 21	52-122-693-806	>	>	>
3-421-9	Set Collar	2	Bronze	52-114-034-031	>	>	>
3-902-3	Set Screw-Set Collar	2	316 Stainless Steel	CP-617-039-369	>	>	>
0-952-0	Seal Piping Parts	1	Plastic	52-127-292-503	>	>	>
0-952-0	Seal Piping Parts	1	Copper	52-127-292-504	>	>	>
Model 150 Standard EPDM Coupling Selection. See Pages 33 and 34.							
ANSI/OSHA Coupling & Bracket Kit Selection Charts. See Pages 35.							
DIAMETER OF IMPELLER LISTED				S-17.70"/ L-17.30"	20.20"	12.80"	12.70"
0-002-0	Imp. Assy. (Small Cap)		Bronze	52-220-811-564	52-327-903-501	N/A	N/A
0-002-0	Imp. Assy. (Medium Cap)		Bronze	N/A	N/A	52-220-757-501	52-220-756-501
0-002-0	Imp. Assy. (Large Cap)		Bronze	52-225-622-501	52-327-907-501	N/A	N/A
0-004-0	Imp. Wear Ring		Bronze	08-996-357-004	08-999-049-002	08-999-049-002	08-975-994-001
4-002-0	Impeller (Small Cap)		Bronze	08-105-085-057	52-327-901-001	N/A	N/A
4-002-0	Impeller (Medium Cap)		Bronze	N/A	N/A	08-105-316-001	08-105-924-053
4-002-0	Impeller (Large Cap)		Bronze	52-322-941-001	52-327-909-001	N/A	N/A

Factory Recommended Spare Parts

Note: Part sheets valid for pumps manufactured after June 1999. Serial number must be provided for pumps manufactured prior to this date.



**MECHANICAL SEAL OVER SHAFT SLEEVE**

CAT. NO.	PART DESCRIPTION	QTY.	MATERIAL	10x12x12XL IMP. ONLY	10x12x12XL IMP. ASSY. ONLY	10x12x14	10x12x17
2-001-0	Casing	1	Cast Iron	52-116-926-501	52-129-590-501	52-128-803-501	>
2-123-5	Casing Gasket-Suct.	1	Vellumoid	52-122-073-005	>	52-128-806-005	>
2-123-6	Casing Gasket Disch.	1	Vellumoid	52-122-074-005	>	52-128-805-005	>
2-904-1	Capscrew		Hardened Steel	N/A	N/A	CP-611-314-613	>
2-904-1	Capscrew		Hardened Steel	CP-611-314-615	>	>	>
2-904-1	Capscrew		Hardened Steel	J92017	>	CP-617-511-691	>
2-916-1	Casing Taper Pin	2	Steel	CP-671-139-491	>	>	>
3-003-9	Casing Ring Assy.	2	Bronze	08-104-599-518	52-260-234-501	08-104-599-504	>
3-003-9	Casing Ring Assy.	2	Cast Iron	08-104-599-519	N/A	08-104-599-505	>
3-003-9	Casing Ring Assy.	2	Nitronic 60	52-127-084-509	52-260-234-502	52-127-084-508	>
3-943-9	Casing Ring, Spirol Pin	2	302 Stainless Steel	CP-671-181-371	>	>	>
3-914-2	Casing Ring – O-Ring	2	Rubber	CP-751-531-991	>	CP-751-531-949	>
3-914-1	Stuff Box – O-Ring	2	Rubber	CP-751-531-270	>	>	>
3-911-2	Coupling Key	1	Steel	CP-677-103-238	>	>	>
3-911-1	Impeller Key	1	Steel	CP-677-051-246	>	>	>
3-025-3	Brg. House (Inb.)	1	Cast Iron	52-239-570-001	>	>	>
3-025-4	Brg. House (Outb.)	1	Cast Iron	52-239-571-001	>	>	>
3-026-3	Bearing (Inb.)	1	Steel	52-113-301-009	>	>	>
3-026-4	Bearing (Outb.)	1	Steel	CP-811-443-295	>	>	>
3-516-4	Locknut, Brg.	1	Steel	CP-819-111-208	>	>	>
3-517-4	Lockwasher, Brg.	1	Steel	CP-819-133-208	>	>	>
3-177-9	Lip Seal	2	Rubber & Steel	CP-753-383-021	>	>	>
3-136-9	Deflector	2	Rubber & Steel	52-108-475-011	>	>	>
3-904-9	Brg. Hsg. Screw (Inb.)	2	Steel	CP-611-271-482	>	>	>
3-904-9	Brg. Hsg. Screw (Outb.)	2	Steel	CP-611-271-484	>	>	>
3-073-9	Stuff Box Assy.	2	Cast Iron	52-427-546-501	>	>	>
3-943-9	Stuff Box Spirol Pin	2	302 Stainless Steel	CP-671-181-309	>	>	>
3-009-9	Shaft Sleeve	2	Bronze	52-239-540-501	>	52-239-538-501	>
3-009-9	Shaft Sleeve	2	316 Stainless Steel	52-239-540-504	>	52-239-538-504	>
0-944-0	Shaft Sleeve Lock Pin	2	316 Stainless Steel	52-114-088-007	>	>	>
3-914-9	Sleeve, O-Ring	2	Rubber	CP-751-531-442	>	>	>
3-015-9	Shaft Nut	2	Bronze	52-128-642-001	>	>	>
3-015-9	Shaft Nut	2	Nitronic 60	52-128-642-002	>	>	>
3-902-3	Shaft Nut Setscrew	2	316 Stainless Steel	CP-617-039-367	>	>	>
3-007-0	Shaft	1	1045 Steel	52-239-351-001	>	52-239-349-001	>
3-007-0	Shaft	1	316 Stainless Steel	52-239-351-002	>	52-239-349-002	>
0-400-0	Mech. Seal	2	BF <sub>50</sub> 1O <sub>10</sub> 1 Type 21	52-122-693-806	>	>	>
3-421-9	Set Collar	2	Bronze	52-114-034-031	>	>	>
3-902-3	Set Screw-Set Collar	2	316 Stainless Steel	CP-617-039-369	>	>	>
0-952-0	Seal Piping Parts	1	Plastic	52-127-292-503	>	>	>
0-952-0	Seal Piping Parts	1	Copper	52-127-292-504	>	>	>
	Model 150 Standard EPDM Coupling Selection. See Pages 33 and 34.						
	ANSI/OSHA Coupling & Bracket Kit Selection Charts. See Pages 35.						
<b>DIAMETER OF IMPELLER LISTED</b>				<b>13.50"</b>	<b>12.80"</b>	<b>14.0"</b>	<b>17.50"</b>
0-002-0	Imp. Assy. (Med. Cap)		Bronze	N/A	N/A	52-225-036-501	52-220-694-501
0-002-0	Imp. Assy. (XL Cap)		Bronze	N/A	52-260-488-501	N/A	N/A
0-004-0	Imp. Wear Ring		Bronze	N/A	52-260-487-001	08-999-049-002	
4-002-0	Impeller (Med. Cap)		Bronze	N/A	N/A	52-116-699-001	08-105-086-001
4-002-0	Impeller (XL Cap)		Bronze	52-360-503-001	N/A	N/A	N/A

 Factory Recommended Spare Parts

Note: Part sheets valid for pumps manufactured after June 1999. Serial number must be provided for pumps manufactured prior to this date.

## MECHANICAL SEAL OVER SHAFT

### INDEX

PAGE	DESCRIPTION
19	Mechanical Sleeve Over Shaft Exploded View
20	2x3x11S&L, 4X6X10a, 4x6x10M
21	4x6x12A, 4x6x14A, 4x6x14L
22	6x8x12S&L, 6x8x12M, 6x8x12XL
23	6x8x13, 6x8x17M&L, 8x8x12, 8x8x17, 8x10x12S&L
24	8x10x17S&L, 8x10x20S&L, 10x10x12, 10x12x12M
25	10x12x12XL, 10x12x14, 10x12x17
	<b>Conversion Tables</b>
28	Mech. Seal Over Sleeve to Packing
30-31	Series 150 Standard EDPM Coupling Selection
32	ANSI/OSHA Coupling & Bracket Kit Selection Charts

### FRAME DESIGNATION

PUMP SIZE	FRAME	PUMP SIZE	FRAME
2x3x11S&L	F20-A5	6x8x17M&L	F20-D5
4x6x10A	F20-C5	8x8x12	F20-D5
4x6x10M	F20-B5	8x8x17	F20-E5
4x6x12A	F20-B5	8x10x12S&L	F20-E5
4x6x14A,L	F20-C5	8x10x17S&L	F20-E5
6x8x10A	F20-I5	8x10x20S&L	F20-E5
6x8x12S&L	F20-C5	10x10x12	F20-F5
6x8x12XL	F20-C5	10x12x12M&XL	F20-F5
6x8x12M	F20-B5	10x12x14	F20-E5
6x8x13	F20-D5	10x12x17	F20-E5

# MECHANICAL SEAL OVER SHAFT

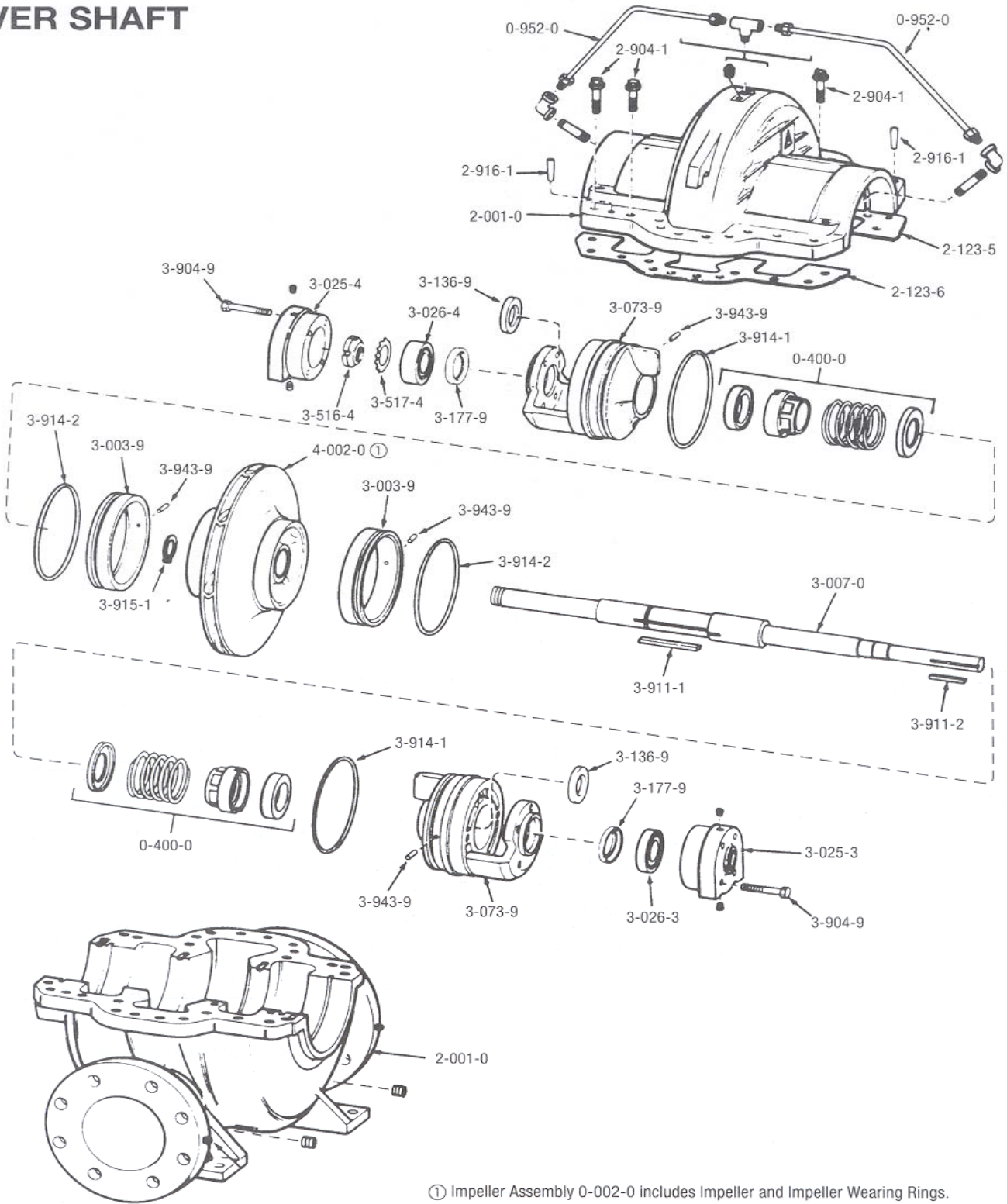

## MECHANICAL SEAL OVER SHAFT

CAT. NO.	PART DESCRIPTION	QTY.	MATERIAL	2x3x11S,L	4x6x10A	4x6x10M IMP. ONLY	4x6x10M IMP. ASSY. ONLY
2-001-0	Casing	1	Cast Iron	52-116-916-501	52-460-745-501	52-116-917-501	52-116-917-511
2-123-5	Casing Gasket-Suct.	1	Vellumoid	52-117-348-005	52-260-249-005	52-117-415-005	>
2-123-6	Casing Gasket Disch.	1	Vellumoid	52-117-347-005	52-260-248-005	52-117-414-005	>
2-904-1	Capscrew		Hardened Steel	CP-611-314-613	CP-611-314-615	>	>
2-904-1	Capscrew		Hardened Steel	N/A	CP-611-314-618	CP-611-314-617	>
2-904-1	Capscrew		Hardened Steel	CP-611-314-616	J92017	>	>
2-916-1	Casing Taper Pin	2	Steel	CP-671-139-491	>	>	>
3-003-9	Casing Ring Assy.	2	Bronze	52-117-232-501	52-117-118-501	52-117-418-501	52-117-118-501
3-003-9	Casing Ring Assy.	2	Cast Iron	52-117-232-502	52-117-118-502	52-117-418-502	52-117-118-502
3-943-9	Cas. Ring, Spirol Pin	2	302 Stainless Steel	CP-671-181-371	52-105-715-020	>	>
3-914-2	Casing Ring - O-Ring	2	Rubber	CP-751-531-924	CP-751-531-932	CP-751-561-028	CP-751-531-932
3-914-1	Stuff Box - O-Ring	2	Rubber	CP-751-531-954	CP-751-531-264	>	>
3-911-2	Coupling Key	1	Steel	AC0522	>	CP-677-103-191	>
3-911-1	Impeller Key	1	Steel	CP-677-103-183	>	CP-677-051-146	>
3-025-3	Brg. House (Inb.)	1	Cast Iron	52-239-562-001	>	52-239-566-001	>
3-025-4	Brg. House (Outb.)	1	Cast Iron	52-239-563-001	>	52-239-567-001	>
3-026-3	Bearing (Inb.)	1	Steel	52-113-300-006	>	CP-811-005-293	>
3-026-4	Bearing (Outb.)	1	Steel	CP-811-443-227	>	CP-811-443-269	>
3-516-4	Locknut, Brg.	1	Steel	CP-819-111-206	>	CP-819-111-207	>
3-517-4	Lockwasher, Brg.	1	Steel	CP-819-133-206	>	CP-819-133-207	>
3-177-9	Lip Seal	2	Rubber & Steel	CP-753-030-535	>	CP-753-030-907	>
3-136-9	Deflector	2	Rubber & Steel	52-117-840-002	>	52-108-475-009	>
3-904-9	Brg. Hsg. Screw (Inb.)	2	Steel	DJ0081	>	CP-611-271-482	>
3-904-9	Brg. Hsg. Screw (Outb.)	2	Steel	CP-611-271-482	>	CP-611-271-484	>
3-073-9	Stuff Box Assy.	2	Cast Iron	52-427-335-501	AC8435/AC8436	52-427-362-501	>
3-943-9	Stuff Box Spirol Pin	2	302 Stainless Steel	CP-671-181-371	>	>	>
3-915-1	Snap Ring (Impeller)	1	420 Stn. Stl. Hardened	CP-673-201-168	>	CP-673-201-196	>
3-007-0	Shaft	1	416 Stainless Steel	52-239-342-001	52-261-289-001	52-239-344-001	>
0-400-0	Mech. Seal	2	BF <sub>50</sub> TO <sub>10</sub> 1 Type 21	52-121-998-801	>	52-121-998-802	>
3-007-0	Shaft *	1	416 Stainless Steel	52-239-383-001	AC8441	52-239-395-001	>
0-400-0	Mech. Seal *	2	BF <sub>50</sub> TO <sub>10</sub> 1 Type 1-B	52-161-211-801	>	52-161-211-802	>
0-952-0	Seal Piping Parts	1	Plastic	52-127-292-503	>	>	>
0-952-0	Seal Piping Parts	1	Copper	52-127-292-504	>	>	>
Model 150 Standard EPDM Coupling Selection. See Pages 33 and 34.							
ANSI/OSHA Coupling & Bracket Kit Selection Charts. See Pages 35.							
DIAMETER OF IMPELLER LISTED				11.00"	9.80"	S,L-11.00"/ M-12.00"	12.00"
0-002-0	Imp. Assy. (Small Cap)		Bronze	52-235-591-501	N/A	52-225-402-501	N/A
0-002-0	Imp. Assy. (Med. Cap)		Bronze	N/A	N/A	N/A	52-235-812-501
0-002-0	Imp. Assy. (Lrg. Cap)		Bronze	52-225-401-501	N/A	52-225-403-501	N/A
0-004-0	Imp. Wear Ring		Bronze	08-998-120-001	N/A	08-975-856-001	08-998-246-001
4-002-0	Impeller (Small Cap)		Bronze	52-235-573-001	N/A	52-117-268-001	N/A
4-002-0	Impeller (Med. Cap)		Bronze	N/A	N/A	52-233-459-001	N/A
4-002-0	Impeller (Lrg. Cap)		Bronze	52-117-447-110	AC2699	52-117-343-001	N/A

\* Balanced Mechanical seal only, used with balanced shaft

Factory Recommended Spare Parts

Note: Part sheets valid for pumps manufactured after June 1999. Serial number must be provided for pumps manufactured prior to this date.

**MECHANICAL SEAL OVER SHAFT**

CAT. NO.	PART DESCRIPTION	QTY.	MATERIAL	4x6x12A	4x6x14A	4x6x14L	6x8x10A
2-001-0	Casing	1	Cast Iron	52-116-917-511	52-129-588-501	52-116-919-501	AC2440
2-135-5	Casing Gasket-Suct.	1	Vellumoid	52-117-415-005	52-111-314-005	52-117-366-005	AC2437
2-123-6	Casing Gasket Disch.	1	Vellumoid	52-117-414-005	52-111-315-005	52-117-367-005	AC2438
2-904-1	Capscrew		Hardened Steel	CP-611-314-615	>	CP-611-314-613	CP-611-314-615
2-904-1	Capscrew		Hardened Steel	CP-611-314-618	N/A	J92017	N/A
2-916-1	Casing Taper Pin	2	Steel	CP-671-139-491	>	>	>
3-003-9	Casing Ring Assy.	2	Bronze	52-117-118-501	52-260-233-501	52-117-118-501	AC8486
3-003-9	Casing Ring Assy.	2	Cast Iron	52-117-118-502	52-260-233-502	52-117-118-502	AC2720
3-943-9	Cas. Ring, Spirol Pin	2	302 Stainless Steel	52-105-715-020	>	>	>
3-914-2	Casing Ring – O-Ring	2	Rubber	CP-751-531-932	>	CP-751-531-932	CP-751-531-937
3-914-1	Stuff Box – O-Ring	2	Rubber	CP-751-531-264	>	>	>
3-911-2	Coupling Key	1	Steel	CP-677-103-191	AC0522	>	CP-677-103-191
3-911-1	Impeller Key	1	Steel	CP-677-051-146	CP-677-103-183	>	AC2732
3-025-3	Brg. House (Inb.)	1	Cast Iron	52-239-562-001	>	>	52-239-566-001
3-025-4	Brg. House (Outb.)	1	Cast Iron	52-239-563-001	>	>	52-239-567-001
3-026-3	Bearing (Inb.)	1	Steel	52-113-300-006	>	>	CP-811-005-293
3-026-4	Bearing (Outb.)	1	Steel	CP-811-443-227	>	>	CP-811-443-269
3-516-4	Locknut, Brg.	1	Steel	CP-819-111-206	>	>	CP-819-111-207
3-517-4	Lockwasher, Brg.	1	Steel	CP-819-133-206	>	>	CP-819-133-207
3-177-9	Lip Seal	2	Rubber & Steel	CP-753-030-535	>	>	CP-753-030-907
3-136-9	Deflector	2	Rubber & Steel	52-117-840-002	>	>	52-108-475-009
3-904-9	Brg. Hsg. Screw (Inb.)	2	Steel	DJ0081	>	>	CP-611-271-482
3-904-9	Brg. Hsg. Screw (Outb.)	2	Steel	CP-611-271-482	>	>	CP-611-271-484
3-073-9	Stuff Box Assy.	2	Cast Iron	52-427-064-501	>	>	AC2428/AC2429
3-943-9	Stuff Box Spirol Pin	2	302 Stainless Steel	CP-671-181-371	>	>	CP-673-201-196
3-915-1	Snap Ring (Impeller)	1	420 Stn. Stl. Hardened	CP-673-201-196	CP-673-201-168	>	CP-673-201-243
3-007-0	Shaft	1	416 Stainless Steel	52-239-344-001	52-239-346-001	>	AC2708
0-400-0	Mech. Seal	2	BF <sub>50</sub> 1O <sub>10</sub> 1 Type 21	52-121-998-802	52-121-998-801	>	52-122-693-804
3-007-0	Shaft *	1	416 Stainless Steel	52-239-395-001	52-239-384-001	>	N/A
0-400-0	Mech. Seal *	2	BF <sub>50</sub> 1O <sub>10</sub> 1 Type 1-B	52-161-211-802	52-161-211-801	>	N/A
0-952-0	Seal Piping Parts	1	Plastic	52-127-292-503	>	>	>
0-952-0	Seal Piping Parts	1	Copper	52-127-292-504	>	>	>
Model 150 Standard Coupling Selection. See Pages 33 and 34.							
ANSI/OSHA Coupling & Bracket Kit Selection Charts. See Page 35.							
<b>DIAMETER OF IMPELLER LISTED</b>				<b>12.00"</b>	<b>13.80"</b>	<b>13.80"</b>	<b>9.88"</b>
0-002-0	Imp. Assy. (Small Cap)		Bronze	N/A	N/A	52-225-190-501	N/A
0-002-0	Imp. Assy. (Lrg. Cap)		Bronze	N/A	N/A	52-225-405-501	N/A
0-004-0	Imp. Wear Ring		Bronze	N/A	N/A	08-998-246-001	N/A
4-002-0	Impeller (Small Cap)		Bronze	N/A	N/A	52-117-222-001	N/A
4-002-0	Impeller (Lrg. Cap)		Bronze	AC8447	AC8449	52-117-374-001	AC8481

\* Balanced Mechanical seal only, used with balanced shaft

Factory Recommended Spare Parts

Note: Part sheets valid for pumps manufactured after June 1999. Serial number must be provided for pumps manufactured prior to this date.

**MECHANICAL SEAL OVER SHAFT**

CAT. NO.	PART DESCRIPTION	QTY.	MATERIAL	6x8x12S,L	6X8x12M IMP. ONLY	6X8x12M IMP. ASSY. ONLY	6X8x12XL IMP. ONLY	6X8x12XL IMP. ASSY. ONLY
2-001-0	Casing	1	Cast Iron	52-116-920-501	>	52-116-920-514	52-116-920-501	52-116-920-514
2-123-5	Casing Gasket-Suct.	1	Vellumoid	52-111-310-005	>	>	>	>
2-123-6	Casing Gasket Disch.	1	Vellumoid	52-111-311-005	>	>	>	>
2-904-1	Capscrew		Hardened Steel	CP-611-314-615	>	>	>	>
2-904-1	Capscrew		Hardened Steel	J92017	>	>	>	>
2-916-1	Casing Taper Pin	2	Steel	CP-671-139-491	>	>	>	>
3-003-9	Casing Ring Assy.	2	Bronze	52-117-117-501	>	52-126-809-501	52-117-117-501	52-126-809-501
3-003-9	Casing Ring Assy.	2	Cast Iron	52-118-082-501	>	52-126-809-502	52-118-082-501	52-126-809-502
3-943-9	Cas. Ring, Spirol Pin	2	302 Stainless Steel	CP-671-181-371	>	>	>	>
3-914-2	Casing Ring – O-Ring	2	Rubber	CP-751-531-937	>	CP-751-531-938	CP-751-531-937	>
3-914-1	Stuff Box – O-Ring	2	Rubber	CP-751-531-264	>	>	>	>
3-911-2	Coupling Key	1	Steel	AC0522	CP-677-103-191	>	>	>
3-911-1	Impeller Key	1	Steel	CP-677-103-183	CP-677-051-146	>	>	>
3-025-3	Brg. House (Inb.)	1	Cast Iron	52-239-562-001	52-239-566-001	>	>	>
3-025-4	Brg. House (Outb.)	1	Cast Iron	52-239-563-001	52-239-567-001	>	>	>
3-026-3	Bearing (Inb.)	1	Steel	52-113-300-006	CP-811-005-293	>	>	>
3-026-4	Bearing (Outb.)	1	Steel	CP-811-443-227	CP-811-443-269	>	>	>
3-516-4	Locknut, Brg.	1	Steel	CP-819-111-206	CP-819-111-207	>	>	>
3-517-4	Lockwasher, Brg.	1	Steel	CP-819-133-206	CP-819-133-207	>	>	>
3-177-9	Lip Seal	2	Rubber & Steel	CP-753-030-535	CP-753-030-907	>	>	>
3-136-9	Deflector	2	Rubber & Steel	52-117-840-002	52-108-475-009	>	>	>
3-904-9	Brg. Hsg. Screw (Inb.)	2	Steel	DJ0081	CP-611-271-482	>	>	>
3-904-9	Brg. Hsg. Screw (Outb.)	2	Steel	CP-611-271-482	CP-611-271-484	>	>	>
3-073-9	Stuff Box Assy.	2	Cast Iron	52-427-064-501	52-235-854-002	>	>	>
3-943-9	Stuff Box Spirol Pin	2	302 Stainless Steel	CP-671-181-371	>	>	>	>
3-915-1	Snap Ring (Impeller)	1	420 Stn. Stl. Hardened	CP-673-201-168	CP-673-201-196	>	>	>
3-007-0	Shaft	1	416 Stainless Steel	52-239-346-001	52-239-344-001	>	>	>
0-400-0	Mech. Seal	2	BF <sub>50</sub> 1O <sub>10</sub> 1 Type 21	52-121-998-801	52-121-998-802	>	>	>
3-007-0	Shaft *	1	416 Stainless Steel	52-239-384-001	52-239-395-001	>	>	>
0-400-0	Mech. Seal *	2	BF <sub>50</sub> 1O <sub>10</sub> 1 Type 1-B	52-161-211-801	52-161-211-802	>	>	>
0-952-0	Seal Piping Parts	1	Plastic	52-127-292-503	>	>	>	>
0-952-0	Seal Piping Parts	1	Copper	52-127-292-504	>	>	>	>
Model 150 Standard Coupling Selection. See Pages 33 and 34.								
ANSI/OSHA Coupling & Bracket Kit Selection Charts. See Page 35.								
DIAMETER OF IMPELLER LISTED				12.80"	12.80"	12.80"	13.40"	13.40"
0-002-0	Imp. Assy. (Small Cap)		Bronze	52-238-621-501	N/A	N/A	N/A	N/A
0-002-0	Imp. Assy. (Med. Cap)		Bronze	N/A	N/A	52-236-592-501	N/A	N/A
0-002-0	Imp. Assy. (Lrg. Cap)		Bronze	52-220-846-501	N/A	N/A	N/A	N/A
0-002-0	Imp. Assy. (XL Cap)		Bronze	N/A	N/A	N/A	N/A	52-260-231-501
0-004-0	Imp. Wear Ring		Bronze	52-115-029-001	N/A	52-126-810-001	N/A	52-260-227-001
4-002-0	Impeller (Small Cap)		Bronze	52-117-327-000	N/A	N/A	N/A	N/A
4-002-0	Impeller (Med. Cap)		Bronze	N/A	52-122-249-001	N/A	N/A	N/A
4-002-0	Impeller (Lrg. Cap)		Bronze	52-322-152-000	N/A	N/A	N/A	N/A
4-002-0	Impeller (XL Cap)		Bronze	N/A	N/A	N/A	52-360-234-001	N/A

\* Balanced Mechanical seal only, used with balanced shaft

Factory Recommended Spare Parts

Note: Part sheets valid for pumps manufactured after June 1999. Serial number must be provided for pumps manufactured prior to this date.

**MECHANICAL SEAL OVER SHAFT**

CAT. NO.	PART DESCRIPTION	QTY.	MATERIAL	6x8x13	6x8x17M,L	8x8x12	8x8x17	8x10x12S,L
2-001-0	Casing	1	Cast Iron	52-118-401-501	52-116-921-501	52-116-968-501	52-116-922-501	52-116-923-501
2-123-5	Casing Gasket-Suct.	1	Vellumoid	52-122-059-005	52-122-061-005	52-122-063-005	52-122-065-005	52-122-067-005
2-123-6	Casing Gasket Disch.	1	Vellumoid	52-122-060-005	52-112-062-005	52-122-064-005	52-122-066-005	52-122-068-005
2-904-1	Capscrew		Hardened Steel	CP-611-314-615	>	>	>	>
2-904-1	Capscrew		Hardened Steel	J92017	>	>	>	>
2-916-1	Casing Taper Pin	2	Steel	CP-671-139-491	>	>	>	>
3-003-9	Casing Ring Assy.	2	Bronze	08-104-599-507	08-104-599-510	>	08-104-599-507	08-104-599-501
3-003-9	Casing Ring Assy.	2	Cast Iron	08-104-599-508	08-104-599-511	08-104-599-503	08-104-599-508	08-104-599-503
3-943-9	Casing Ring, Spirol Pin	2	302 Stainless Steel	CP-671-181-371	>	>	>	>
3-914-2	Casing Ring – O-Ring	2	Rubber	CP-751-531-940	CP-751-531-939	CP-751-531-944	CP-751-531-940	CP-751-531-944
3-914-1	Stuff Box – O-Ring	2	Rubber	CP-751-531-268	>	>	CP-751-531-270	>
3-911-2	Coupling Key	1	Steel	CP-677-103-191	>	>	CP-677-103-238	>
3-911-1	Impeller Key	1	Steel	CP-677-051-153	>	>	CP-677-051-246	>
3-025-3	Brg. House (Inb.)	1	Cast Iron	52-239-566-001	>	>	52-239-570-001	>
3-025-4	Brg. House (Outb.)	1	Cast Iron	52-239-567-001	>	>	52-239-571-001	>
3-026-3	Bearing (Inb.)	1	Steel	CP-811-005-293	>	>	52-113-301-009	>
3-026-4	Bearing (Outb.)	1	Steel	CP-811-443-269	>	>	CP-811-443-295	>
3-516-4	Locknut, Brg.	1	Steel	CP-819-111-207	>	>	>	>
3-517-4	Lockwasher, Brg.	1	Steel	CP-819-133-207	>	>	>	>
3-177-9	Lip Seal	2	Rubber & Steel	CP-753-030-907	>	>	CP-753-383-021	>
3-136-9	Deflector	2	Rubber & Steel	52-108-475-009	>	>	52-108-475-011	>
3-904-9	Brg. Hsg. Screw (Inb.)	2	Steel	CP-611-271-482	>	>	>	>
3-904-9	Brg. Hsg. Screw (Outb.)	2	Steel	CP-611-271-484	>	>	>	>
3-073-9	Stuff Box Assy.	2	Cast Iron	52-427-243-501	>	>	52-427-145-501	>
3-943-9	Stuff Box Spirol Pin	2	302 Stainless Steel	CP-671-181-309	>	>	>	>
3-915-1	Snap Ring (Impeller)	1	420 Stn. Stl. Hardened	CP-673-201-196	>	>	CP-673-201-243	>
3-007-0	Shaft	1	416 Stainless Steel	52-239-348-001	>	>	52-239-350-001	>
0-400-0	Mech. Seal	2	BF <sub>50</sub> 1O <sub>10</sub> 1 Type 21	52-121-998-802	>	>	52-121-998-803	>
3-007-0	Shaft *	1	416 Stainless Steel	52-239-396-001	>	>	52-239-385-001	>
0-400-0	Mech. Seal *	2	BF <sub>50</sub> 1O <sub>10</sub> 1 Type 1-B	52-161-211-802	>	>	52-161-211-804	>
0-952-0	Seal Piping Parts	1	Plastic	52-127-292-503	>	>	>	>
0-952-0	Seal Piping Parts	1	Copper	52-127-292-504	>	>	>	>
Model 150 Standard EPDM Coupling Selection. See Pages 33 and 34.								
ANSI/OSHA Coupling & Bracket Kit Selection Charts. See Page 35.								
<b>DIAMETER OF IMPELLER LISTED</b>				<b>13.10"</b>	<b>17.00"</b>	<b>12.80"</b>	<b>17.70"</b>	<b>12.80"</b>
0-002-0	Imp. Assy. (Small Cap)		Bronze	N/A	N/A	N/A	N/A	52-220-877-501
0-002-0	Imp. Assy. (Med. Cap)		Bronze	52-220-825-564	52-225-078-501	52-220-692-501	52-220-784-502	N/A
0-002-0	Imp. Assy. (Lrg. Cap)		Bronze	N/A	52-220-693-506	N/A	N/A	52-221-827-501
0-004-0	Imp. Wear Ring		Bronze	08-982-211-002	08-978-606-001	08-996-357-004	08-982-211-002	08-107-221-001
4-002-0	Impeller (Small Cap)		Bronze	N/A	N/A	N/A	N/A	08-105-840-001
4-002-0	Impeller (Med. Cap)		Bronze	08-105-173-065	52-117-099-001	08-105-084-001	08-105-687-059	N/A
4-002-0	Impeller (Lrg. Cap)		Bronze	N/A	08-105-900-006	N/A	N/A	52-115-223-001

\* Balanced Mechanical seal only, used with balanced shaft

	Factory Recommended Spare Parts
--	---------------------------------

Note: Part sheets valid for pumps manufactured after June 1999. Serial number must be provided for pumps manufactured prior to this date.

## MECHANICAL SEAL OVER SHAFT

CAT. NO.	PART DESCRIPTION	QTY.	MATERIAL	8x10x17S,L	8x10x20S,L	10x10x12	10x12x12M
2-001-0	Casing	1	Cast Iron	52-116-924-501	52-128-321-501	52-116-925-501	52-116-926-501
2-135-5	Casing Gasket-Suct.	1	Vellumoid	52-122-069-005	52-239-078-005	52-122-071-005	52-122-073-005
2-123-6	Casing Gasket Disch.	1	Vellumoid	52-122-070-005	52-239-077-005	52-122-072-005	52-122-074-005
2-904-1	Capscrew		Hardened Steel	CP-611-314-613	>	>	N/A
2-904-1	Capscrew		Hardened Steel	CP-611-314-615	>	>	>
2-904-1	Capscrew		Hardened Steel	J92017	>	>	>
2-916-1	Casing Taper Pin	2	Steel	CP-671-139-491	>	>	>
3-003-9	Casing Ring Assy.	2	Bronze	08-104-599-501	>	08-104-599-504	08-104-599-518
3-003-9	Casing Ring Assy.	2	Cast Iron	08-104-599-503	>	08-104-599-505	08-104-599-519
3-943-9	Casing Ring, Spirol Pin	2	302 Stainless Steel	CP-671-181-371	>	>	>
3-914-2	Casing Ring – O-Ring	2	Rubber	CP-751-531-944	>	CP-751-531-949	CP-751-531-991
3-914-1	Stuff Box – O-Ring	2	Rubber	CP-751-531-270	>	>	>
3-911-2	Coupling Key	1	Steel	CP-677-103-238	>	>	>
3-911-1	Impeller Key	1	Steel	CP-677-051-246	>	>	>
3-025-3	Brg. House (Inb.)	1	Cast Iron	52-239-570-001	>	>	>
3-025-4	Brg. House (Outb.)	1	Cast Iron	52-239-571-001	>	>	>
3-026-3	Bearing (Inb.)	1	Steel	52-113-301-009	>	>	>
3-026-4	Bearing (Outb.)	1	Steel	CP-811-443-295	>	>	>
3-516-4	Locknut, Brg.	1	Steel	CP-819-111-208	>	>	>
3-517-4	Lockwasher, Brg.	1	Steel	CP-819-133-208	>	>	>
3-177-9	Lip Seal	2	Rubber & Steel	CP-753-383-021	>	>	>
3-136-9	Deflector	2	Rubber & Steel	52-108-475-011	>	>	>
3-904-9	Brg. Hsg. Screw (Inb.)	2	Steel	CP-611-271-482	>	>	>
3-904-9	Brg. Hsg. Screw (Outb.)	2	Steel	CP-611-271-484	>	>	>
3-073-9	Stuff Box Assy.	2	Cast Iron	52-427-145-501	>	>	>
3-943-9	Stuff Box Spirol Pin	2	302 Stainless Steel	CP-671-181-309	>	>	>
3-915-1	Snap Ring (Impeller)	1	420 Stn. Stl. Hardened	CP-673-201-243	>	>	>
3-007-0	Shaft	1	416 Stainless Steel	52-239-350-001	>	52-239-352-001	>
0-400-0	Mech. Seal	2	BF <sub>50</sub> 1O <sub>10</sub> 1 Type 21	52-121-998-803	>	>	>
3-007-0	Shaft *	1	416 Stainless Steel	52-239-385-001	>	52-239-386-001	>
0-400-0	Mech. Seal *	2	BF <sub>50</sub> 1O <sub>10</sub> 1 Type 1-B	52-161-211-804	>	>	>
0-952-0	Seal Piping Parts	1	Plastic	52-127-292-503	>	>	>
0-952-0	Seal Piping Parts	1	Copper	52-127-292-504	>	>	>
Model 150 Standard Coupling Selection. See Pages 33 and 34.							
ANSI/OSHA Coupling & Bracket Kit Selection Charts. See Page 35.							
DIAMETER OF IMPELLER LISTED				S-17.70"/ L-17.3"	20.20"	12.80"	12.70"
0-002-0	Imp. Assy. (Small Cap)		Bronze	52-220-811-564	52-327-903-501	N/A	N/A
0-002-0	Imp. Assy. (Med. Cap)		Bronze	N/A	N/A	52-220-757-501	52-220-756-501
0-002-0	Imp. Assy. (Lrg. Cap)		Bronze	52-225-622-501	52-327-907-501	N/A	N/A
0-004-0	Imp. Wear Ring		Bronze	08-996-357-004	08-999-049-002	08-999-049-002	08-975-994-001
4-002-0	Impeller (Small Cap)		Bronze	08-105-085-057	52-327-901-001	N/A	N/A
4-002-0	Impeller (Med. Cap)		Bronze	N/A	N/A	08-105-316-001	08-105-924-053
4-002-0	Impeller (Lrg. Cap)		Bronze	52-322-941-001	52-327-909-001	N/A	N/A

\* Balanced Mechanical seal only, used with balanced shaft

Factory Recommended Spare Parts

Note: Part sheets valid for pumps manufactured after June 1999. Serial number must be provided for pumps manufactured prior to this date.



**MECHANICAL SEAL OVER SHAFT**

CAT. NO.	PART DESCRIPTION	QTY.	MATERIAL	10x12x12XL IMP. ONLY	10X12x12XL IMP. ASSY. ONLY	10x12x14	10x12x17
2-001-0	Casing	1	Cast Iron	52-116-926-501	52-129-590-501	52-128-803-501	>
2-135-5	Casing Gasket-Suct.	1	Vellumoid	52-122-073-005	>	52-128-806-005	>
2-123-6	Casing Gasket Disch.	1	Vellumoid	52-122-074-005	>	52-128-805-005	>
2-904-1	Capscrew		Hardened Steel	N/A	N/A	CP-611-314-613	>
2-904-1	Capscrew		Hardened Steel	CP-611-314-615	>	>	>
2-904-1	Capscrew		Hardened Steel	J92017	>	CP-617-511-691	>
2-916-1	Casing Taper Pin	2	Steel	CP-671-139-491	>	>	>
3-003-9	Casing Ring Assy.	2	Bronze	08-104-599-518	52-260-234-501	08-104-599-504	>
3-003-9	Casing Ring Assy.	2	Cast Iron	08-104-599-519	N/A	08-104-599-505	>
3-943-9	Casing Ring, Spirol Pin	2	302 Stainless Steel	CP-671-181-371	>	>	>
3-914-2	Casing Ring – O-Ring	2	Rubber	CP-751-531-991	>	CP-751-531-949	>
3-914-1	Stuff Box – O-Ring	2	Rubber	CP-751-531-270	>	>	>
3-911-2	Coupling Key	1	Steel	CP-677-103-238	>	>	>
3-911-1	Impeller Key	1	Steel	CP-677-051-246	>	>	>
3-025-3	Brg. House (Inb.)	1	Cast Iron	52-239-570-001	>	>	>
3-025-4	Brg. House (Outb.)	1	Cast Iron	52-239-571-001	>	>	>
3-026-3	Bearing (Inb.)	1	Steel	52-113-301-009	>	>	>
3-026-4	Bearing (Outb.)	1	Steel	CP-811-443-295	>	>	>
3-516-4	Locknut, Brg.	1	Steel	CP-819-111-208	>	>	>
3-517-4	Lockwasher, Brg.	1	Steel	CP-819-133-208	>	>	>
3-177-9	Lip Seal	2	Rubber & Steel	CP-753-383-021	>	>	>
3-136-9	Deflector	2	Rubber & Steel	52-108-475-011	>	>	>
3-904-9	Brg. Hsg. Screw (Inb.)	2	Steel	CP-611-271-482	>	>	>
3-904-9	Brg. Hsg. Screw (Outb.)	2	Steel	CP-611-271-484	>	>	>
3-073-9	Stuff Box Assy.	2	Cast Iron	52-427-145-501	>	>	>
3-943-9	Stuff Box Spirol Pin	2	302 Stainless Steel	CP-671-181-309	>	>	>
3-915-1	Snap Ring (Impeller)	1	420 Stn. Stl. Hardened	CP-673-201-243	>	>	>
3-007-0	Shaft	1	416 Stainless Steel	52-239-352-001	>	52-239-350-001	>
0-400-0	Mech. Seal	2	BF <sub>50</sub> 1O <sub>10</sub> 1 Type 21	52-121-998-803	>	>	>
3-007-0	Shaft *	1	416 Stainless Steel	52-239-386-001	>	52-239-385-001	>
0-400-0	Mech. Seal *	2	BF <sub>50</sub> 1O <sub>10</sub> 1 Type 1-B	52-161-211-804	>	>	>
0-952-0	Seal Piping Parts	1	Plastic	52-127-292-503	>	>	>
0-952-0	Seal Piping Parts	1	Copper	52-127-292-504	>	>	>
Model 150 Standard Coupling Selection. See Pages 33 and 34.							
ANSI/OSHA Coupling & Bracket Kit Selection Charts. See Page 35.							
DIAMETER OF IMPELLER LISTED				13.50"	13.50"	14.00"	17.50"
0-002-0	Imp. Assy. (Med. Cap)		Bronze	N/A	N/A	52-225-036-501	52-220-694-501
0-002-0	Imp. Assy. (XL Cap)		Bronze	N/A	52-260-488-501	N/A	N/A
0-004-0	Imp. Wear Ring		Bronze	N/A	52-260-487-001	08-999-049-002	N/A
4-002-0	Impeller (Med. Cap)		Bronze	N/A	N/A	52-116-699-001	08-105-086-001
4-002-0	Impeller (XL Cap)		Bronze	52-360-503-001	N/A	N/A	N/A

\* Balanced Mechanical seal only, used with balanced shaft

Factory Recommended Spare Parts

Note: Part sheets valid for pumps manufactured after June 1999. Serial number must be provided for pumps manufactured prior to this date.

## CONVERSION TABLE

### PARTS NECESSARY TO CONVERT FROM **STANDARD PACKING** TO **STANDARD MECHANICAL SEAL** OVER SHAFT SLEEVE

#### DELETE PACKING

Cat. Code	No. Req.	Part Name
3-073-9	2	Stuff Box Assembly
3-009-9	2	Shaft Sleeve
1-924-9	12	Packing
1-014-9	2	Gland
3-904-9	4	Gland Screw
1-909-9	2	Gland Washer
2-123-5	1	Casing Gasket-Suction
2-123-6	1	Casing Gasket-Discharge
3-914-2	2	Casing O-Ring
3-914-1	2	Stuff Box O-Ring
3-026-3	1	Bearing (Inboard)
3-026-4	1	Bearing (Outboard)
3-177-9	2	Lip Seal

#### ADD MECHANICAL SEAL

Cat. Code	No. Req.	Part Name
3-073-9	2	Stuff Box Assembly
3-009-9	2	Shaft Sleeve
0-400-0	2	Mechanical Seal
3-421-9	2	Set Collar
3-902-3	4	Set Screw - Set Collar
0-952-0	1	Seal Piping Parts
2-123-5	1	Casing Gasket-Suction
2-123-6	1	Casing Gasket-Discharge
3-914-2	2	Casing O-Ring
3-914-1	2	Stuff Box O-Ring
3-026-3	1	Bearing (Inboard)
3-026-4	1	Bearing (Outboard)
3-177-9	2	Lip Seal

#### OPTIONAL PARTS

Cat. Code	No. Req.	Part Name
1-013-9	2	Seal Cages
0-952-0	1	Seal Piping Parts

For Part Numbers See Section

**Mechanical Seal Over Shaft Sleeve** (pages 12 thru 17)

**Note:** See Instruction Manual for Mechanical Seal  
Setting Dimension

## CONVERSION TABLE

### PARTS NECESSARY TO CONVERT FROM **STANDARD PACKING** TO **STANDARD MECHANICAL SEAL OVER SHAFT**

#### DELETE PACKING

Cat. Code	No. Req.	Part Name
3-073-9	2	Stuff Box Assembly
3-009-9	2	Shaft Sleeve
3-007-0	1	Shaft
3-015-9	2	Shaft Nut
3-902-3	2	Shaft Nut Screw
1-924-9	12	Packing
1-014-9	2	Gland
3-904-9	4	Gland Screw
1-909-9	2	Gland Washer
2-123-5	1	Casing Gasket-Suction
2-123-6	1	Casing Gasket-Discharge
3-914-2	2	Casing O-Ring
3-914-1	2	Stuff Box O-Ring
3-026-3	1	Bearing (Inboard)
3-026-4	1	Bearing (Outboard)
3-177-9	2	Lip Seal

#### ADD MECHANICAL SEAL OVER SHAFT

Cat. Code	No. Req.	Part Name
3-073-9	2	Stuff Box Assembly
3-915-1	1	Snap Ring (Impeller)
3-007-0	1	Shaft
0-400-0	2	Mechanical Seal
0-952-0	1	Seal Piping Parts
2-123-5	1	Casing Gasket-Suction
2-123-6	1	Casing Gasket-Discharge
3-914-2	2	Casing O-Ring
3-914-1	2	Stuff Box O-Ring
3-026-3	1	Bearing (Inboard)
3-026-4	1	Bearing (Outboard)
3-177-9	2	Lip Seal

#### OPTIONAL PARTS

Cat. Code	No. Req.	Part Name
1-013-9	2	Seal Cages
0-952-0	1	Seal Piping Parts

For Part Numbers See Section  
**Mechanical Seal Over Shaft** (pages 20 thru 25)

**Note:** This Mechanical Seal requires no setting  
Dimension. See Instruction Manual.

## CONVERSION TABLE

### PARTS NECESSARY TO CONVERT FROM **STANDARD MECHANICAL SEAL** OVER SHAFT SLEEVE TO **STANDARD PACKING**

#### DELETE MECH. SEAL OVER SHAFT SLEEVE

Cat. Code	No. Req.	Part Name
3-073-9	2	Stuff Box Assembly
3-009-9	2	Shaft Sleeve
0-400-0	2	Mechanical Seal
3-421-9	2	Set Collar
3-902-3	4	Set Screw – Set Collar
0-952-0	1	Seal Piping Parts
2-123-5	1	Casing Gasket-Suction
2-123-6	1	Casing Gasket-Discharge
3-914-2	2	Casing O-Ring
3-914-1	2	Stuff Box O-Ring
3-026-3	1	Bearing (Inboard)
3-026-4	1	Bearing (Outboard)
3-177-9	2	Lip Seal

#### ADD PACKING

Cat. Code	No. Req.	Part Name
3-073-9	2	Stuff Box Assembly
3-009-9	2	Shaft Sleeve
1-924-9	12	Packing
1-014-9	2	Gland
3-904-9	4	Gland Screw
1-909-9	2	Gland Washer
2-123-5	1	Casing Gasket-Suction
2-123-6	1	Casing Gasket-Discharge
3-914-2	2	Casing O-Ring
3-914-1	2	Stuff Box O-Ring
3-026-3	1	Bearing (Inboard)
3-026-4	1	Bearing (Outboard)
3-177-9	2	Lip Seal

#### OPTIONAL PARTS

Cat. Code	No. Req.	Part Name
1-013-9	2	Seal Cages
0-952-0	1	Seal Piping Parts

For Part Numbers See Section

**Packing Over Shaft Sleeve** (pages 4 thru 9)

## CONVERSION TABLE

### PARTS NECESSARY TO CONVERT FROM **STANDARD MECHANICAL SEAL** OVER SHAFT TO **STANDARD PACKING**

#### DELETE MECHANICAL SEAL OVER SHAFT

Cat. Code	No. Req.	Part Name
3-073-9	2	Stuff Box Assembly
3-915-1	1	Snap Ring (Impeller)
3-007-0	1	Shaft
0-400-0	2	Mechanical Seal
0-952-0	1	Seal Piping Parts
2-123-5	1	Casing Gasket-Suction
2-123-6	1	Casing Gasket-Discharge
3-914-2	2	Casing O-Ring
3-914-1	2	Stuff Box O-Ring
3-026-3	1	Bearing (Inboard)
3-026-4	1	Bearing (Outboard)
3-177-9	2	Lip Seal

#### ADD PACKING

Cat. Code	No. Req.	Part Name
3-073-9	2	Stuff Box Assembly
3-009-9	2	Shaft Sleeve
3-007-0	1	Shaft
3-015-9	2	Shaft Nut
3-902-3	2	Shaft Nut Screw
1-924-9	12	Packing
1-014-9	2	Gland
3-904-9	4	Gland Screw
1-909-9	2	Gland Washer
2-123-5	1	Casing Gasket-Suction
2-123-6	1	Casing Gasket-Discharge
3-914-2	2	Casing O-Ring
3-914-1	2	Stuff Box O-Ring
3-026-3	1	Bearing (Inboard)
3-026-4	1	Bearing (Outboard)
3-177-9	2	Lip Seal

#### OPTIONAL PARTS

Cat. Code	No. Req.	Part Name
1-013-9	2	Seal Cages
0-952-0	1	Seal Piping Parts

For Part Numbers See Section

**Packing Over Shaft Sleeve** (pages 4 thru 9)

## SERIES HSC & HSC-S MODEL 150 COUPLING SELECTION – STANDARD EPDM

### Pump Models with 1200 RPM ODP Motor

PUMP	PUMP SHAFT	PUMP HALF	MOTOR FRAME SIZE	MOTOR HP	MOTOR SHAFT	MOTOR HALF	SLEEVE NO.	VENDOR ID
2x3x11S,L	1-1/8"	AC1559	182T-184T	1 ½-2	1-1/8"	AC1559	AC1440	5JE
4x6x10A	1-1/8"	AC1561	213T-215T	3-5	1-3/8"	AC1562	AC1441	6JE
4x6x14A,L	1-1/8"	52-219-923-259	254T-256T	7½-10	1-5/8"	AC1465	AC1442	7JES
6x8x12S,L,XL	1-1/8"	52-219-923-309	284T	15	1-7/8"	AC1469	AC1443	8JES
	1-1/8"	52-219-923-359	286T	20	1-7/8"	AC1472	AC1444	9JES
	1-1/8"	52-219-923-359	324T	25	2-1/8"	AC1473	AC1444	9JES
	1-1/8"	52-219-923-409	326T	30	2-1/8"	AC1477	AC1445	10JES
4x6x10M	1-3/8"	AC1562	182T-184T	1 ½-2	1-1/8"	AC1561	AC1441	6JE
4x6x12A	1-3/8"	AC1562	213T-215T	3-5	1-3/8"	AC1562	AC1441	6JE
6x8x10A	1-3/8"	AC1464	254T-256T	7½-10	1-5/8"	AC1465	AC1442	7JES
6x8x12M	1-3/8"	AC1467	284T	15	1-7/8"	AC1469	AC1443	8JES
6x8x13	1-3/8"	AC1470	286T	20	1-7/8"	AC1472	AC1444	9JES
6x8x17M,L	1-3/8"	AC1470	324T	25	2-1/8"	AC1473	AC1444	9JES
8x8x12	1-3/8"	AC1474	326T	30	2-1/8"	AC1477	AC1445	10JES
8x8x17	1-5/8"	AC1465	254T-256T	7½-10	1-5/8"	AC1465	AC1442	7JES
8x10x12S,L	1-5/8"	AC1468	284T	15	1-7/8"	AC1469	AC1443	8JES
8x10x17S,L	1-5/8"	AC1471	286T	20	1-7/8"	AC1472	AC1444	9JES
8x10x20S,L	1-5/8"	AC1471	324T	25	2-1/8"	AC1473	AC1444	9JES
10x10x12	1-5/8"	AC1475	326T	30	2-1/8"	AC1477	AC1445	10JES
10x12x12M,XL	1-5/8"	AC1475	364T	40	2-3/8"	AC1478	AC1445	10JES
10x12x14	1-5/8"	AC1480	365T	50	2-3/8"	AC1483	P78802	11JES
10x12x17	1-5/8"	AC1480	404T	60	2-7/8"	AC1484	P78802	11JES
	1-5/8"	AC1485	405T	75	2-7/8"	AC1487	P81933	12JES

### Pump Models With 1800 RPM ODP Motor

PUMP	PUMP SHAFT	PUMP HALF	MOTOR FRAME SIZE	MOTOR HP	MOTOR SHAFT	MOTOR HALF	SLEEVE NO.	VENDOR ID
2x3x11S,L	1-1/8"	AC1559	182T-184T	3-5	1-1/8"	AC1559	AC1440	5JE
4x6x10A	1-1/8"	AC1561	213T-215T	7½-10	1-3/8"	AC1561	AC1441	6JE
4x6x14A,L	1-1/8"	AC1463	254T	15	1-5/8"	AC1465	AC1442	7JES
6x8x12S,L,XL	1-1/8"	52-219-923-309	256T	20	1-5/8"	AC1468	AC1443	8JES
	1-1/8"	52-219-923-309	284T	25	1-7/8"	AC1469	AC1443	8JES
	1-1/8"	52-219-923-359	286T	30	1-7/8"	AC1472	AC1444	9JES
	1-1/8"	52-219-923-359	324T	40	2-1/8"	AC1473	AC1445	10JES
	1-1/8"	52-219-923-409	326T	50	2-1/8"	AC1477	AC1445	10JES
	1-1/8"	52-219-923-409	364T	60	2-3/8"	AC1478	AC1445	10JES
	1-1/8"	52-114-058-450	365T	75	2-3/8"	AC1483	P78802	11E
	1-1/8"	52-114-058-450	404-405T	100	2-7/8"	AC1487	P78802	SC-12
4x6x10M	1-3/8"	AC1562	182T-184T	3-5	1-1/8"	AC1560	AC1441	6JE
4x6x12A	1-3/8"	AC1561	213T	7½-10	1-3/8"	AC1461	AC1441	6JE
6x8x10A	1-3/8"	AC1464	254T	15	1-5/8"	AC1465	AC1442	7JES
6x8x12M	1-3/8"	AC1467	256T	20	1-5/8"	AC1468	AC1443	8JES
6x8x13	1-3/8"	AC1467	284T	25	1-7/8"	AC1469	AC1443	8JES
6x8x17M,L	1-3/8"	AC1470	286T	30	1-7/8"	AC1472	AC1444	9JES
8x8x12	1-3/8"	AC1470	324T	40	2-1/8"	AC1473	AC1444	9JES
	1-3/8"	AC1474	326T	50	2-1/8"	AC1477	AC1445	10JES
	1-3/8"	AC1474	364T	60	2-3/8"	52-219-923-423	AC1445	10JES
8x8x17	1-5/8"	AC1465	254T	15	1-5/8"	AC1465	AC1442	7JES
8x10x12S,L	1-5/8"	AC1468	256T	20	1-5/8"	AC1468	AC1443	8JES
8x10x17S,L	1-5/8"	AC1468	284T	25	1-7/8"	AC1469	AC1443	8JES
8x10x20S,L	1-5/8"	AC1471	286T	30	1-7/8"	AC1472	AC1444	9JES
10x10x12	1-5/8"	AC1471	324T	40	2-1/8"	AC1473	AC1444	9JES
10x12x12M,XL	1-5/8"	AC1475	326T	50	2-1/8"	AC1477	AC1445	10JES
10x12x14	1-5/8"	AC1475	364TS	60	1-7/8"	AC1476	AC1445	10JES
10x12x17	1-5/8"	AC1480	365TS	75	1-7/8"	AC1481	P78802	11JES
	1-5/8"	AC1480	404TS-405TS	100	2-1/8"	52-219-923-467	P78802	11JES
	1-5/8"	AC1485	405T	125	2-7/8"	AC1487	P81933	12JES
	1-5/8"	AC1485	444TS	150	2-3/8"	52-219-923-519	P81933	12JES

\* Requires a bushing. See table on Page 31.

## SERIES HSC & HSC-S MODEL 150 COUPLING SELECTION – STANDARD EPDM

### Pump Models with 3600 RPM ODP Motor

PUMP	PUMP SHAFT	PUMP HALF	MOTOR FRAME SIZE	MOTOR HP	MOTOR SHAFT	MOTOR HALF	SLEEVE NO.	VENDOR ID
2x3x11S,L	1-1/8"	AC1559	182T-184T	5-7 ½	1-1/8"	AC1559	AC1440	5JE
	1-1/8"	AC1561	213T-215T	10-15	1-3/8"	AC1562	AC1441	6JE
	1-1/8"	52-219-923-259	254T-256T	20-25	1-5/8"	AC1465	AC1442	7JES
	1-1/8"	52-219-923-259	284TS-286TS	30	1-5/8"	AC1465	AC1442	7JES
	1-1/8"	52-219-923-309	286TS	40	1-5/8"	AC1468	AC1443	8JES
	1-1/8"	52-219-923-309	324TS-326TS	50	1-7/8"	AC1469	AC1443	8JES
	1-1/8"	52-219-923-359	326TS	60	1-7/8"	AC1472	AC1444	9JES
	1-1/8"	52-219-923-409	365TS	300	1-7/8"	AC1476	AC1445	10JES
4x6x10M 6x8x12M	1-3/8"	AC1464	254T-256T	20-25	1-5/8"	AC1465	AC1442	7JES
	1-3/8"	AC1464	284TS	30	1-5/8"	AC1465	AC1442	7JES
	1-3/8"	AC1467	286TS	40	1-5/8"	AC1468	AC1443	8JES
	1-3/8"	AC1467	324TS-326TS	50	1-7/8"	AC1469	AC1443	8JES
	1-3/8"	AC1470	326TS	60	1-7/8"	AC1472	AC1444	9JES
	1-3/8"	AC1470	364TS	75	1-7/8"	AC1472	AC1444	9JES
	1-3/8"	AC1474	365TS	100	1-7/8"	AC1476	AC1445	10JES
	1-3/8"	AC1474	404TS-405TS	100-125	2-1/8"	AC1477	AC1446	10JES
	1-3/8"	AC1479	444TS-445TS	200	2-3/8"	AC1483	P78802	11JES
	*							

\* Requires a bushing. See table below.

½ COUPLING	BUSHING NO.	BORE SIZE	VENDOR NO.
52-114-058-450	52-219-928-459	1-1/8"	11SF
AC1551	52-219-923-511	1-3/8"	12E
AC1552	52-219-928-561	1-3/8"	13F
AC1552	AC1557	1-5/8"	13F
52-114-058-600	52-219-928-613	1-5/8"	14F

**Note:** For all non-standard HSC Series 150 couplings and all HSC Series 300 couplings, contact the factory for the replacement.

## ANSI/OSHA GUARD & BRACKET KIT SELECTION CHART FOR SERIES HSC & HSC-S PUMPS

**COUPLER GUARD KIT PART NUMBERS: 1 = 186884 2 = 186885 3 = 186886 6 = 186887 7 = 185327**  
C = CONSULT FACTORY

### SERIES HSC & HSC-S MODEL 150 WITH STANDARD EPDM COUPLING

PUMP SIZE	BRACKET KIT	MOTOR FRAME / GUARD KIT NUMBER																																	
		143T	145T	182T	184T	213T	215T	254T	256T	284T	284TS	286T	286TS	324T	324TS	326T	326TS	364T	364TS	365T	365TS	404T	404TS	405T	405TS	444T	444TS	445T	445TS	447T	447TS	449T	449TS		
2x3x11S,L	1DN001	1	1	1	1	2	2	2	2	2	2	2	2	2	2	2	2	2	2	2	6	C													
4x6x10M	1DN002			2	2	2	2	2	2	2	2	2	2	2	2	2	2	2	2	2	7	C	7	C	7	C	C	C	C	C					
4x6x10A	1DN002				2	2	2	2	2	2	2	2	2	2	2	2	2	2	2	2															
4x6x12A	1DN001						2	2	2	2	2	2	2	2	2	2	2	2	2	2															
4x6x14A	1DN001			2	2	2	2	2	2	2	2	2	2	2	2	2	2	2	2	2	7	C													
4x6x14L	1DN001			1	1	2	2	2	2	2	2	2	2	2	2	2	2	2	2	2	6	C													
6x8x10A	1DN001					2	2	2	2	2	2	2	2	2	2	2	2	2	2	2															
6x8x12S,L,XL	1DN001			1	1	2	2	2	2	2	2	2	2	2	2	2	2	2	2	2	6	C													
6x8x12M	1DN002						2	2	2	2	2	2	2	2	2	2	2	2	2	2	7	C	7	C	7	C	C	C	C	C					
6x8x13	1DN002							2	2	2	2	2	2	2	2	2	2	2	2	2	7	C	7	C	7	C	C	C	C	C					
6x8x17M,L	1DN002								2	2	2	2	2	2	2	2	2	2	2	2	7	C	7	C	7	C	C	C	C	C					
8x8x12	1DN002							2	2	2	2	2	2	2	2	2	2	2	2	2	7	C	7	C	7	C	C	C	C						
8x8x17	1DN003													3	2	3	2	3	2	2	7	C	7	C	7	C	C	C	C	C	C	C	C	C	
8x10x12S,L	1DN003							2	2	2	2	2	2	2	2	2	2	2	2	2	7	C	7	C	7	C	C	C	C	C	C	C	C	C	C
8x10x17S,L	1DN003													3	2	3	2	3	2	2	7	C	7	C	7	C	C	C	C	C	C	C	C	C	
8x10x20S,L	1DN003													3	2	3	2	3	2	2	7	C	7	C	7	C	C	C	C	C	C	C	C	C	
10x10x12	1DN003									2	2	2	2	3	2	3	2	3	2	2	7	C	7	C	7	C	C	C	C	C	C	C	C	C	
10x12x12M,XL	1DN003									2	2	2	2	3	2	3	2	3	2	2	7	C	7	C	7	C	C	C	C	C	C	C	C	C	
10x12x14	1DN003													3	2	3	2	3	2	2	7	C	7	C	7	C	C	C	C	C	C	C	C	C	
10x12x17	1DN003													3	2	3	2	3	2	2	7	C	7	C	7	C	C	C	C	C	C	C	C	C	

**HOW TO USE THIS CHART TO SELECT A COUPLER GUARD AND BRACKET KIT:**  
 Example (shaded grey above): Pump Model = 4x6x14L w/ a 50 HP, 460 Volt, 3 PH, 1800 RPM, 326T Fr. motor.  
 The Coupler Guard kit is 186885 and would require a 1DN001 bracket kit.



# Xylem |'zīləm|

- 1) The tissue in plants that brings water upward from the roots;
- 2) a leading global water technology company.

We're a global team unified in a common purpose: creating advanced technology solutions to the world's water challenges. Developing new technologies that will improve the way water is used, conserved, and re-used in the future is central to our work. Our products and services move, treat, analyze, monitor and return water to the environment, in public utility, industrial, residential and commercial building services settings. Xylem also provides a leading portfolio of smart metering, network technologies and advanced analytics solutions for water, electric and gas utilities. In more than 150 countries, we have strong, long-standing relationships with customers who know us for our powerful combination of leading product brands and applications expertise with a strong focus on developing comprehensive, sustainable solutions.

**For more information on how Xylem can help you, go to [www.xyleminc.com](http://www.xyleminc.com)**

We value your feedback. Please take our 3 question survey at **[bellgossett.com/survey](http://bellgossett.com/survey)** to let us know how we are doing.



Xylem Inc.  
8200 N. Austin Avenue  
Morton Grove, Illinois 60053  
Phone: (847) 966-3700  
Fax: (847) 965-8379  
[www.bellgossett.com](http://www.bellgossett.com)

Bell & Gossett is a trademark of Xylem Inc. or one of its subsidiaries.  
© 2018 Xylem Inc. CP-505D-PL April 2018