



Shown with optional
variable speed drive

Series e-80SC

Split-Coupled Vertical In-Line Centrifugal Pump



Series e-80SC Split-Coupled Vertical In-Line Centrifugal Pump

Applications

- Hydronic Heating and Cooling Systems
- Light Industrial Process
- General Service

Advantages

- Best in Class Hydraulic Performance
- Patent-Pending Shaft Jacking Coupling
- Easy Maintenance
- Optional Flange Mounting Supports

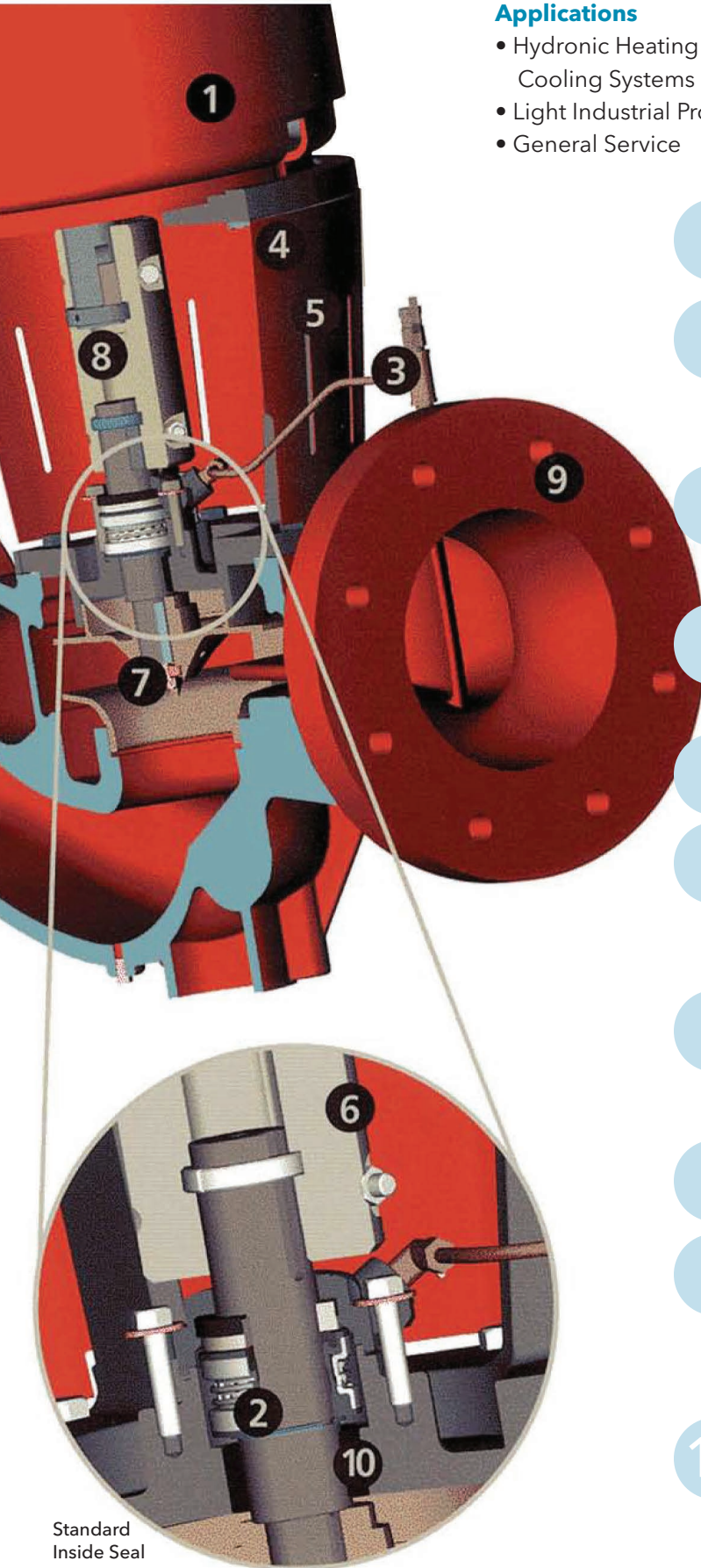

Standard Inside Seal

1 Motor

The Series e-80SC will accept 60 Hertz TC-face NEMA Premium motors.

2 Mechanical Seal

The seal has a compact Rotating Unitized Seal Head design for easier seal replacement. The positive metal-to-metal drive system reduces the torsional stress on the bellows. The bellows are pressure supported without creases or folds, creating lower stress, and resulting in longer seal life.

3 External Flush

The external flush line has a manual valve to remove air from the seal chamber to ensure cooling liquid at the seal for fast initial start-up. The flush line is a durable braided hose material which helps to prevent damage during shipment.

4 Motor Bracket

Brackets are designed for a wider access area for easier seal removal. The combination motor bracket/volute coverplate assures positive concentric alignment of the motor to the pump casing.

5 Coupler Guard

Confirms to ANSI and OSHA for safe operation.

Ease of Serviceability

6 The axially-split spacer coupling permits seal maintenance without disturbing the pump or motor. The patent pending shaft jacking design enables a single person to remove and replace the mechanical seal. The seal can be removed through the gap between the pump and motor shaft when the coupler is removed.

7 Impeller

The new e-80SC contains stainless steel impellers to improve sustainable hydraulic performance, chemical resistance, and reduce corrosion potential. The impellers are balanced to ANSI Grade G6.3 to provide years of trouble free service.

8 Pump Shaft

The 416 stainless steel pump shaft provides high levels of corrosion resistance to the pumped fluid.

9 Volute

The e-80SC delivers "best in class" hydraulic performance with proven industry leading efficiencies across Preferred Operating Regions (POR). An Anti-Swirl vane below the impeller eye keeps NPSHR to a minimum. Pumps 5" to 14" include a splitter volute to minimize radial loads for extended bearing and mechanical seal life.

10 Throttle Bushing

Antimony-impregnated carbon graphite throttle bushing for longer service life.

Construction Materials (for parts in contact with fluid pumped)

Description	Stainless Steel Fitted Pump
Shaft	416 Stainless Steel
Volute	Cast Iron ASTM A48 Class 30B
Impeller	ASTM A743 Grade CF8 (304SS)
Impeller Key	Stainless Steel
Impeller Lock Washer	Stainless Steel
Impeller Capscrew	Stainless Steel
Volute Gasket	Cellulose Fiber
Throttle Bushing	Carbon Graphite
Seal Assemblies	
• Standard Seal-Inside Flushed	
Bellows	EPR
Faces	Carbon-Ceramic
Metal Parts	Stainless Steel or Brass
Spring	Stainless Steel or Brass
• Optional Seal -Inside Flushed	
Bellows	EPR
Faces	Carbon-Tungsten Carbide
• Optional Seal-Outside Flushed	
O-Rings	EPR
Faces	Carbon-Ceramic
Metal Parts	Stainless Steel

Standard pump construction is 175 psi working pressure with 125 ANSI flange drilling. Optional 250 psi working pressure with 250 ANSI flange drilling is available.

IT & ITSC Technology

The IT & ITSC option from Bell & Gossett can be packaged with the Series e-80SC pumps. The IT & ITSC option is the energy efficient and economical way to provide variable flow pumping for the broadest range of applications. The Integrated Technologic (IT) is designed for sensed or building automation system control. The IT package is a great alternative for applications that do not require sensorless control. The Integrated Technologic Sensorless Control (ITSC) combines the energy savings of variable flow with sensorless technology to eliminate the cost and time of using wired transducers and sensors.

Seal Selection Guide

A. Standard Seal - Inside with flush line.

EPR/Carbon-Ceramic; Temperature Range -20° to +250°F (-29° to +121°C).
*Maximum pressure is 175 psi (12 bar).

B. Optional Seal - Inside with flush line.

EPR/Carbon-Tungsten Carbide; Temperature Range -20° to + 250°F (-29° to + 121°C). * For use on open or dosed water systems. Maximum pressure is 250 psi (17 bar).

C. Optional Seal - Outside with flush line.

EPR/Carbon-Ceramic Type "8B2"; Temperature Range -20° to +250°F (-29° to + 121°C). * For use on closed or open systems where the pressure requirements exceed the limitations of the standard seal or an alternate seal design is desired. Maximum pressure is 250 psi (17 bar).

*For operating conditions above 250°F (121°C and no greater than 300°F (149°C) a cooled flush is required. On closed systems cooling is accomplished by inserting the optional heat exchanger kit in the flush line to cool the seal flushing fluid.

Flush line filters and sediment separators are available on request.

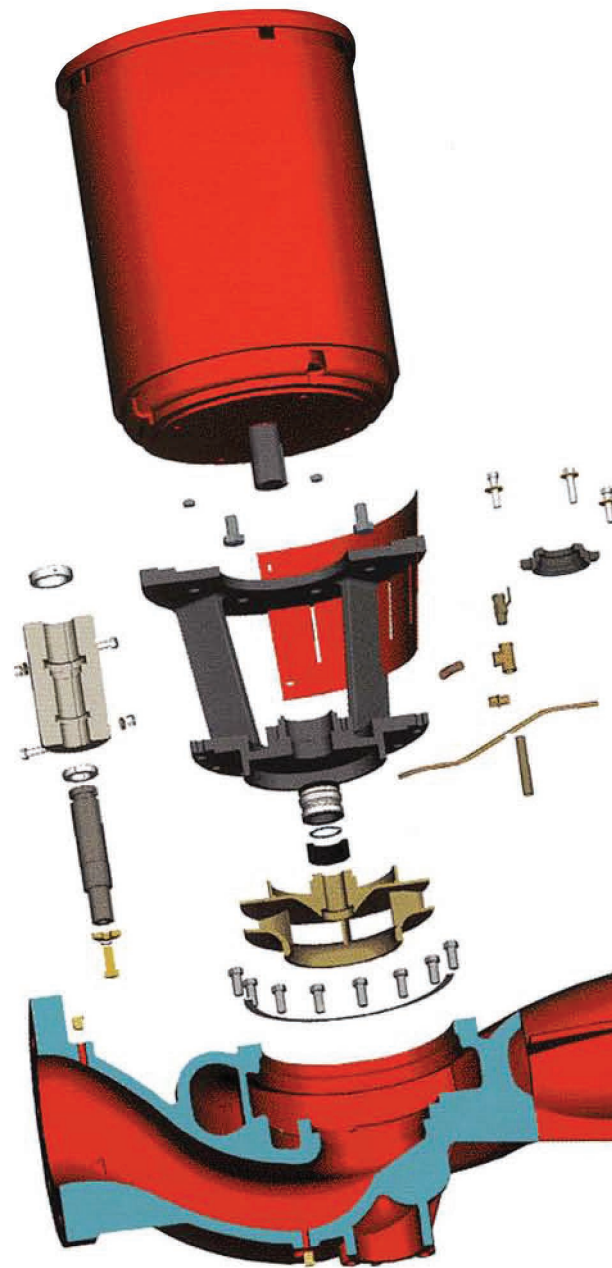

Optional Outside Seal

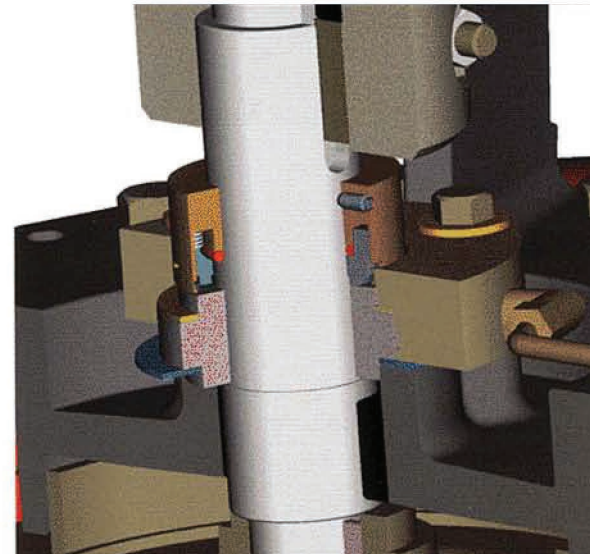

Standard Performance Curves

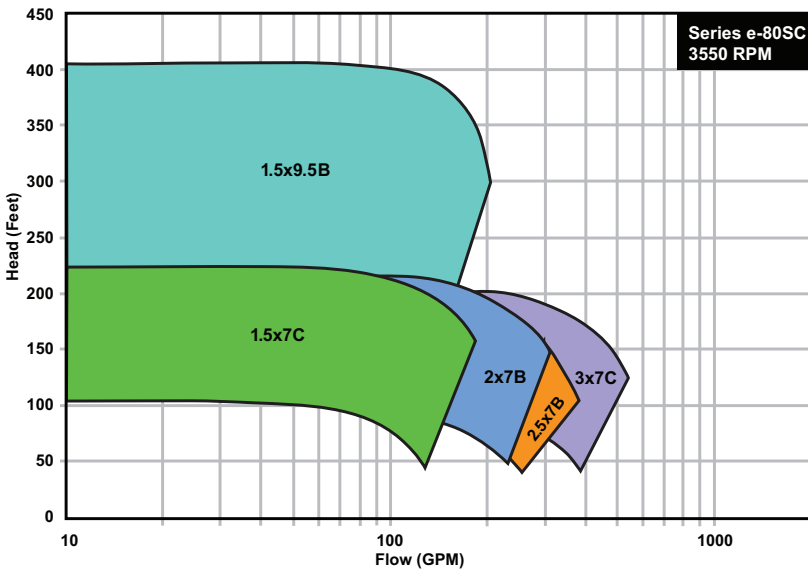
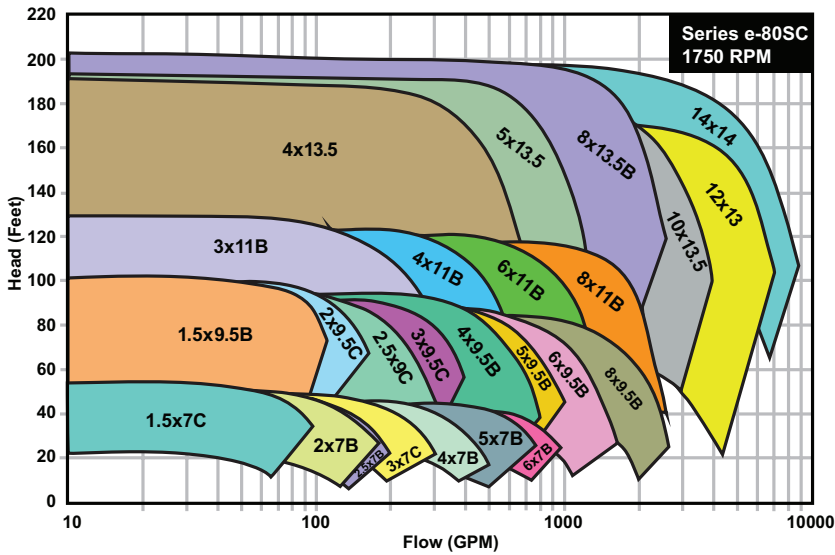

Engineering Specifications

Furnish and install pumps with capacities as shown on plans. Pumps shall be split-coupled in-line, single-stage design, for installation in a vertical position motor up, capable of being serviced without disturbing piping connections.

Pump volute shall be of Class 30 cast iron. It shall be designed with a base ring matching an ANSI 125# flange for pump support. The impeller shall be of stainless steel, enclosed type, balanced to Hydraulic Institute Standards (ANSI/HI 9.6.4.5-2000, figure 9.6.4.158). The allowable residual imbalance conforms to ANSI Grade G6.3, keyed to the stainless steel shaft and secured by a locking capscrew. The pump shaft shall be guided by a carbon graphite lower throttle bushing.

The combination motor bracket and volute coverplate shall be a one-piece unit to ensure concentric alignment of the motor to the pump casing.

The liquid cavity shall have a tapped flush line with manual valve to remove air from the seal chamber for fast initial start-up. The mechanical seal shall have a compact Rotating Unitized Seal Head design with EPR elastomer bellows and a positive metal-to-metal drive system to reduce the torsional stress on the bellows. The bellows will be pressure supported without creases or folds for long life.

The spacer coupling shall be of high tensile aluminum, split to allow the servicing of the seal without disturbing the pump or motor. The motor bracket shall contain a carbon steel coupler guard conforming to both ANSI 815.1 section 8 and OSHA 1910.219 standards for safety.

(Optional) The seal flush line shall be fitted with a factory installed 50 micron cartridge filter (cyclone separator when pump differential pressure exceeds 30 psig) and sight flow indicator.

Pumps shall be rated for continuous operation at a minimum of 175 psi (12 bar) working pressure (optional 250 psi (17 bar)) and 250°F (121°C). The volute shall have gauge tappings at the suction, and discharge nozzles and vent and drain tappings at the top and bottom.

Motor shall be Premium efficient complying to IEC or NEMA specifications and shall be the size, voltage and enclosure called for on the plans. It shall have heavy-duty grease-lubricated ball bearings, completely adequate for the maximum load for which the pump is designed.

Each pump shall be factory tested per Hydraulic Institute standards. It shall then be thoroughly cleaned and painted with at least one coat of high-grade machinery enamel prior to shipment.

Pumps shall be Series e-80SC as manufactured by Bell & Gossett.

We value your feedback. Please take our 3 question survey at bellgossett.com/survey to let us know how we are doing.



Xylem Inc.
8200 N. Austin Avenue
Morton Grove, Illinois 60053
Phone: (847) 966-3700
Fax: (847) 965-8379
www.bellgossett.com

Bell & Gossett is a trademark of Xylem Inc. or one of its subsidiaries.
© 2017 Xylem Inc. B-120A January 2017