

JOB:	REPRESENTATIVE:
UNIT TAG:	ORDER NO.:
ENGINEER:	SUBMITTED BY:
CONTRACTOR:	APPROVED BY:
	DATE:
	DATE:
	DATE:

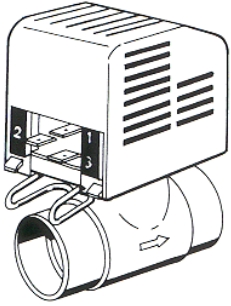

Comfort-Trol™

Zone Control Valve

PATENT NO'S. 4,553,733 AND 4,560,140

DESCRIPTION

A heat motor operated valve designed for zoning hydronic heating/cooling systems utilizing baseboard, convector and fan-coil terminal units.

CONSTRUCTION

Valve Body: Bronze
 Valve Stem: Stainless Steel
 Valve Rubber Parts: EPDM
 Electrical Rating: 24 volt, 50/60 cycle, 1Ø: 15VA
 24 volt, .6 amp DC
 Auxiliary Switch: 24 volt AC, 1 amp max

SCHEDULE

MODEL NO.	SIZE INCHES	VOLTAGE RATING 50/60CY 1Ø	VA RATING	TAGGING INFORMATION	QUANTITY
CTS-7524	3/4	24 VOLT	15		

**WORKING PRESSURE & TEMPERATURE LIMITS
 (SOLDER TYPE LIMITS FOR ASTM STD. B16.18-1978)**

TYPE OF SOLDER	MAXIMUM LIMITATIONS	
	PRESSURE PSI	TEMPERATURE °F
95-5 TIN-ANTIMONY	125	240

CAUTION: Heat associated with the use of silver solder will damage Comfort-Trol and void the product warranty.

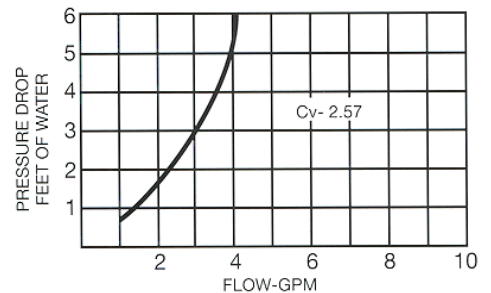
PERFORMANCE CHARACTERISTICS

THERMOSTAT

24 volt systems: 24 volt two wire with a 0.6 ampere heat anticipator setting.

NOTE: THE HEAT ANTICIPATOR SETTING MUST MATCH THE 0.6 AMP RATING OF THE POWER PILL HEATER.

TRANSFORMER

24 volt systems: 115/24 volt rated at 40 VA for a maximum of three Comfort-Trol Zone Valves.

DESIGN LIMITS

Working pressure: 125 PSIG (8.6 bar).
 Fluid temperature range: 40°F to 240°F (4.4°C to 115.6°C).
 Maximum ambient temperature: 125°F (52°C).
 Maximum differential pressure: 35 PSIG (2.4 bar).

DIMENSIONS AND WEIGHTS

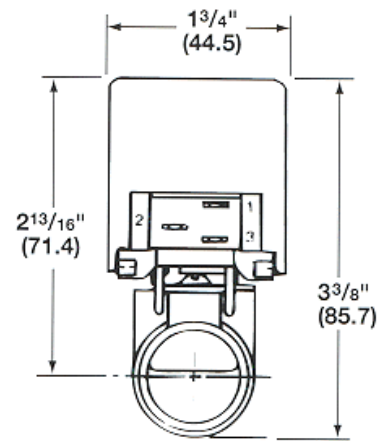
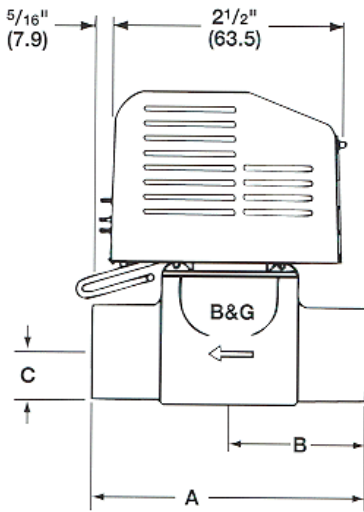

MODEL NO.	CONNECTION SIZE- INCHES	DIMENSIONS IN INCHES (mm)			APPROX. SHPG. WT. LBS. (kg)
		A	B	C	
CTS-7524	3/4 Sweat	3 (76.2)	1 1/2 (38.1)	9/16 (14.5)	1.0 (0.5)

TYPICAL SPECIFICATIONS

Furnish and install as shown on plans, electrically operated heat motor actuated zone control valves. The valves shall provide 100% shut off at a maximum differential pressure of 35 psig (2.4 bar). All units shall be quiet operating and consist of a bronze valve body with sweat connections and a removable valve operator. The operator shall be equipped with a solderless 3-terminal leaf-type stack switch designed to operate on a 24 volt 50/60 hertz single phase 2-wire power source. The 3rd terminal shall be used to control the on/off operation of the system pump as required.

The zone valve shall be designed to handle liquid temperatures from 40°F (4.4°C) up to 240°F (115.6°C) at a maximum working pressure of 125 psig (8.6 bar). The valve design shall include a backseating disc that enables replacement of the seal gland without draining the system. The valve design shall include an external position indicator and 360° rotation of the operator. All operating components shall be protected within a plated steel frame enclosed by the valve operator cover.

All Units shall be Bell & Gossett Model No. CTS-7524.

Xylem Inc.
 8200 N. Austin Avenue
 Morton Grove, IL 60053
 Phone: (847)966-3700
 Fax: (847)965-8379
www.xyleminc.com/brands/bellgossett

