

# Coil Hookup Kits

**INSTALLER:** PLEASE LEAVE THIS MANUAL FOR THE OWNER'S USE.

**NOTICE:** Bell & Gossett does not recommend Coil Hookup Kit components to be used for potable water.

**WARNING:** This product may contain chemicals known to the State of California to cause cancer, or birth defects or other reproductive harm.



**SAFETY INSTRUCTION**

This safety alert symbol will be used in this manual to draw attention to safety related instructions. When used, the safety alert symbol means **ATTENTION! BECOME ALERT! YOUR SAFETY IS INVOLVED! FAILURE TO FOLLOW THE INSTRUCTIONS MAY RESULT IN A SAFETY HAZARD.**

Safety Message Level	Indication
<b>DANGER:</b>	A hazardous situation which, if not avoided, will result in death or serious injury
<b>WARNING:</b>	A hazardous situation which, if not avoided, could result in death or serious injury
<b>CAUTION:</b>	A hazardous situation which, if not avoided, could result in minor or moderate injury
<b>Electrical Hazard:</b>	The possibility of electrical risks if instructions are not followed in a proper manner
<b>NOTICE:</b>	<ul style="list-style-type: none"> <li>A potential situation which, if not avoided, could result in an undesirable result or state</li> <li>A practice not related to personal injury</li> </ul>

# Index

	<b>Page</b>
<b>Operational Limits</b> .....	4
<b>General Information</b> .....	4
For Installing Sweat Connections .....	4
For Installing NPT Connections .....	4
<b>Valve Accessories</b> .....	4
Drain Caps and Cartridge Caps .....	5
How To Use Pressure Taps To Measure System Operating Conditions .....	6
Pipe Hanging Installations .....	6
<b>MC Circuit Setter Valves</b> .....	6
Description .....	6
Installation Instructions .....	6
How To Use B&G Circuit Setter Balance Valves for Pre-Set Flow Balancing .....	6
How To Use B&G Circuit Setters to Proportionally Balance a System .....	7
How To Use B&G Circuit Setter Balance Valves as Flow Meters .....	7
How To Use B&G Circuit Setter Balance Valves as an Isolation Valve .....	7
How To Use the Memory Stop Feature .....	7
Service Instructions .....	7
Insulation .....	7
<b>AC Circuit Sentry Automatic Flow Limiting Valves</b> .....	8
Description .....	8
Installation Instructions .....	8
Operating Instructions .....	8
How To Use B&G Circuit Sentry Flow Limiting Valve Pressure Taps to Determine Proper Functioning of Valve .....	8
Service Instructions .....	8
Insulation .....	8
<b>ACL Low Flow Circuit Sentry Valve</b> .....	9
Description .....	9
Installation Instructions .....	9
Low Flow Circuit Sentry Model ACL Valves with Sweat Connections .....	9
Low Flow Circuit Sentry Model ACL Valves with NPT Connections .....	9
Low Flow Circuit Sentry Model ACL Valves Flow Limiting Cartridge Installation .....	9
How To Use B&G Low Flow Circuit Sentry Model ACL Flow Limiting Valves for Pre-set Flow Balancing .....	10
How To Use Pressure Taps (P/T Ports) to Measure System Operating Conditions .....	10
Service Instructions .....	10
Insulation .....	10
<b>AM Circuit Sentry Flo-Setter Balance &amp; Commissioning Valves</b> .....	10
Description .....	10
Installation Instructions .....	10
Circuit Sentry Flo-Setter Balance Valves with NPT Connections .....	11
How To Use B&G Circuit Sentry Flo-Setter Balancing & Commissioning Valves for Pre-Set Flow Balancing .....	11
How To Use B&G Circuit Sentry Flo-Setter to Proportional Balance a System .....	11
Service Instructions .....	11
Insulation .....	11

	<b>Page</b>
<b>AA Ultra Setter Pressure Independent Control Valves</b> .....	11
Description .....	11
Installation Instructions .....	12
Ultra Setter Pressure Independent Control Valves with NPT Connections .....	12
Ultra Setter Pressure Independent Control Valves with 0-10 VDC Analog Actuator .....	12
Ultra Setter Pressure Independent Control Valves with 24 VAC 3-Position Actuator .....	13
How To Use B&G Ultra Setter Pressure Independent Control Valves for Pre-Set Flow Balancing .....	14
How To Use B&G Ultra Setter to Commission a System .....	14
Service Instructions .....	14
Insulation .....	14
<b>MV Venturi/Ball Valve Combination</b> .....	15
Description .....	15
Installation Instructions .....	15
Operating Instructions .....	15
How To Use B&G MV Venturi/Ball Valves as an Isolation Valve .....	15
How To Use the Memory Stop Feature .....	15
Service Instructions .....	15
Insulation .....	15
<b>UBY Y-Strainer Combination Ball Valve</b> .....	16
Description .....	16
Installation Instructions .....	16
Operating Instructions .....	16
Service Instructions .....	16
Insulation .....	16
<b>UBYL Low Y-Strainer Combination Ball Valve</b> .....	16
Description .....	16
Installation Instructions .....	17
Low Flow Model UBYL Y-Strainer Valves with Sweat Connections .....	17
Low Flow Model UBYL Y-Strainer Valves with NPT Connections .....	17
How To Use B&G Low Flow Model UBYL Y-Strainer Valves .....	17
How To Use Pressure Taps (P/T Ports) to Measure System Operating Conditions .....	17
Service Instructions .....	17
Insulation .....	18
<b>UBV Union-Ended Ball Valve</b> .....	18
Description .....	18
Installation Instructions .....	18
Operating Instructions .....	18
Service Instructions .....	18
<b>UA Union Accessory</b> .....	19
Description .....	19
Installation Instructions .....	19
Operating Instructions .....	19
Service Instructions .....	19
<b>SH Hose</b> .....	19
Description .....	19
Installation Instructions .....	19
Service Instructions .....	20

## OPERATIONAL LIMITS

Coil Hookup Component		Temperature °F (°C)	Max. Working Pressure psi (kPa)
UBV Y-Strainer Valve	NPT	-4°F (-20°C) to 250°F (120°C)	400 PSI (2758kPa)
	Sweat	Based on Solder Type	ASTM Std. B16.18
UBV Union Ended Ball Valve	NPT	-4°F (-20°C) to 250°F (120°C)	400 PSI (2758kPa)
	Sweat	Based on Solder Type	ASTM Std. B16.18
UA Union Adapter	NPT	-4°F (-20°C) to 250°F (120°C)	400 PSI (2758kPa)
	Sweat	Based on Solder Type	ASTM Std. B16.18
MV Venturi Ball Valve	NPT	-4°F (-20°C) to 250°F (120°C)	400 PSI (2758kPa)
	Sweat	Based on Solder Type	ASTM Std. B16.18
AC Circuit Sentry Valve		-4°F (-20°C) to 250°F (120°C)	400 PSI (2758kPa)
MC Circuit Setter Valve		-4°F (-20°C) to 250°F (120°C)	400 PSI (2758kPa)
AA Ultra Setter Valve		32°F (0°C) to 250°F (120°C) - Fluid	300 PSI (2068kPa)
		34°F (1°C) to 122°F (50°C) - Ambient	300 PSI (2068kPa)
AM Circuit Sentry Flo-Setter Valve		14°F (-10°C) to 250°F (120°C)	400 PSI (2758kPa)
UBYL Low Flow Y-Strainer Valve	NPT	-4°F (-20°C) to 250°F (120°C)	400 PSI (2758kPa)
	Sweat	Based on Solder Type	ASTM Std. B16.18
ACL Low Flow Valve	NPT	-4°F (-20°C) to 250°F (120°C)	400 PSI (2758kPa)
	Sweat	Based on Solder Type	ASTM Std. B16.18
SH Hose	1/2"	-40°F (-40°C) to 212°F (100°C)	400 PSI (2758kPa)
	3/4"		400 PSI (2758kPa)
	1"		500 PSI (3447kPa)
	1-1/4"	400 PSI (2758kPa)	
	1-1/2"	-40°F (-40°C) to 450°F (232°C)	300 PSI (2068kPa)
	2"		

Type Solder	Maximum Limitations 1/2" - 1"		Maximum Limitations 1 1/4" - 2"	
	Pressure psi (kPa)	Temp °F (°C)	Pressure psi (kPa)	Temp °F (°C)
95-5	300 (2069)	200 (93)	300 (2069)	175 (79)
TIN-	250 (1724)	225 (107)	250 (1724)	200 (93)
ANTIMONY	200 (1379)	250 (121)	175 (1207)	250 (121)

## GENERAL INFORMATION

**CAUTION:** Installation and maintenance must be performed by a qualified professional. Service should not be performed on any valve in an active Hydronic loop. Before attempting to make any required adjustments, properly isolate and drain the branch loops that require service and allow the valves to reach a safe handling temperature (below 100°F [38°C]) and zero pressure condition. Use proper safety equipment including gloves, goggles, or similar tools to avoid contact with system fluids and common hazards. Failure to follow these instructions could result in personal injury and property damage.

Due to the different types of material used, Bell & Gossett coil hookup kit valves and accessories must be disassembled prior to disposal. Special handling of certain valve components may be required by law or may be sensible from an ecological point of view.

### FOR INSTALLING SWEAT CONNECTIONS:

1. Clean tube ends and valve connections thoroughly per good piping practices with a fine grade emery cloth or fine grit sandpaper.
2. For soldering, use 95-5 (Tin-Antimony) solder and a good grade of flux.
3. Use a torch with a sharp pointed flame.
4. When sweating the joints, first adjust the valve in the full open position, and then wrap the valve with a cool wet rag. Direct the flame with care to avoid subjecting the valve to excessive heat. Allow the valve to cool before touching or operating.
5. Check the soldered connection for leaks.

**CAUTION:** Use of improper procedures to sweat valve model with union connection into system can damage valve. Before installing sweat union connection to valve, remove the union nut and o-ring from the valve body, then union tailpiece with union nut must be sweated (soldered) into place. Make sure the o-ring is reinstalled. Failure to follow this instruction could result in property damage and/or moderate personal injury.

**CAUTION:** Heat associated with the use of silver solder may damage valve components and void the product warranty. Do not use silver solder. Failure to follow these instructions could result in property damage and/or moderate personal injury.

**NOTICE:** Excessive use of solder or flux may result in damage to the shutoff valve seat and ball. Do not use excessive solder or flux.

### FOR INSTALLING NPT CONNECTIONS:

Apply pipe compound conservatively to male connecting fittings only. After installation check all joints for leakage and retighten where necessary.

**NOTICE:** The use of PTFE impregnated pipe compound and PTFE tape on pipe threads provides lubricity. Care should be taken to prevent over tightening which may damage the valve body.

## VALVE ACCESSORIES (P/T Readout Ports, Drain Valves, Plugs, Extenders, Air Vents)

The P/T readout ports, drain valves, plugs, and other accessories found on Bell & Gossett balancing valves (such as Circuit Setter, Circuit Sentry, Ultra Setter, Circuit Sentry Flo-Setter, MV and ACL Low Flow valves), coil hook-up kit valves (such as UBV union ball valve, UBV union ball valve with Y-strainer, and UBYL low flow Y-strainer), and other components (such as UA union accessories and SH hoses) come pre-assembled with Loctite thread sealant and are tightened to appropriate levels. With that in mind, the following information should help to clarify questions regarding the adjustment or servicing of those components when required.



Any field adjustment of factory installed components will break the original thread seal and could cause leakage. This will necessitate the removal, cleaning, and resealing of those parts per the instructions below.

Should any adjustment or servicing of P/T readout ports, drain valves, drain plugs, or other valve accessories be required, please take the following steps:

1. Completely remove the desired component from the valve.
2. Taking care not to damage any threads on the component or the valve, clean off all of the old thread sealant. Use a wire brush and gentle abrasion if necessary. Allow the valve and the component to dry. **Note: If the component or valve appears to have been damaged, replace it.**
3. Starting with the second thread of the NPT male valve component, apply a 360° bead of Loctite 567\* thread sealant/lubricant as shown below. Follow Loctite handling precautions as noted on the product labeling.



4. If Loctite 567 is unavailable, we recommend RectorSeal No. 5\*\* pipe thread sealant for all non-glycol based applications, or any PTFE thread sealing tape. Be sure to follow the manufacturer specific handling precautions and application instructions as noted on the product labeling.
5. Thread component into valve until it is finger tight.
6. Apply torque to the following specification:

COMPONENT		TORQUE
SIZE	TYPE	
1/4" NPT	P/T Readout Port, Drain Valve, Air Vent, Plug, Extender	9.0 ft.-lbs + 3.0 ft.-lbs / -0
1/2" NPT	Plug	9.0 ft.-lbs + 3.0 ft.-lbs / -0
3/4" NPT	Plug	12.0 ft.-lbs + 4.0 ft.-lbs / -0
1" NPT	Plug	12.0 ft.-lbs + 4.0 ft.-lbs / -0

7. Properly assembled valve components will immediately seal to moderate pressure (100 PSI or less). For maximum pressure resistance, allow the Loctite 567 or RectorSeal No. 5 thread sealant to cure for 24 hours. PTFE tape typically does not require curing to achieve maximum pressure resistance.

## DRAIN CAPS AND CARTRIDGE CAPS

Occasionally, the drain cap of a UBY or UBYL Y-strainer valve may need to be disassembled to permit cleaning of the mesh strainer. Likewise, cartridges may need to be removed from Ultra Setter, Flo-Setter, Circuit Sentry, and ACL Low Flow valves for system commissioning or flow adjustment.

Any field adjustment of factory installed drain caps or cartridge caps will affect the compression of the seal present and could cause leakage. This will necessitate the removal, cleaning, and resealing of those parts per the instructions below.

Should any servicing of cartridge caps or drain caps be required, please take the following steps:

1. Completely remove cap from valve. Take care not to damage the valve, cap threads, or o-ring or PTFE seals.
2. When performing maintenance on a UBY or UBYL drain cap, remove the 1/4" NPT drain valve from the cap before removing the drain cap from the valve.
3. Perform necessary service on valve or system. **Note: If the valve or any of the components appear to have been damaged, replace them.**

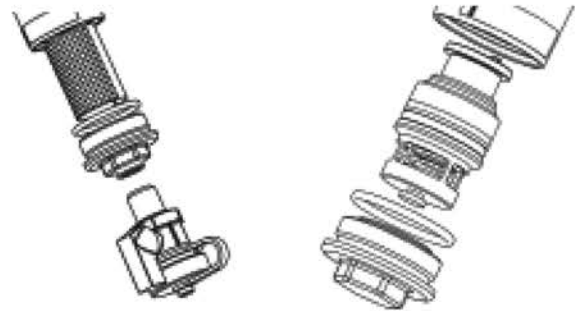

4. Make sure that the male threads of the cap and the female threads of the valve are clean and that there is no debris present.
5. Make sure that o-ring or PTFE seal is seated on the cartridge cap or drain cap.
6. Thread cap into valve until it is finger tight.

**! NOTICE:** Do not use any thread sealant or lubricant when assembling the cartridge or drain cap as it may prevent o-ring or PTFE seal from sealing properly.

7. Tighten cap to specification below.

COMPONENT	SEAL	TORQUE
Cartridge Cap – All Sizes	O-Ring	25.0 ft.-lbs + 7.0 ft.-lbs / -0
Drain Cap – 1/2" and 3/4" UBYL Valves	O-Ring	25.0 ft.-lbs + 7.0 ft.-lbs / -0
Drain Cap – 1/2" and 3/4" UBY Valves	PTFE Square Ring	25.0 ft.-lbs + 7.0 ft.-lbs / -0
Drain Cap – 1" and 1-1/4" UBY Valves	PTFE Square Ring	32.0 ft.-lbs + 10.0 ft.-lbs / -0
Drain Cap – 1-1/2" and 2" UBY Valves	PTFE Square Ring	60.0 ft.-lbs + 18.0 ft.-lbs / -0

\*Loctite and Loctite 567 are registered trademarks of Henkel AG & Co.

\*\*RectorSeal No. 5 is a registered trademark of RectorSeal Corporation.



**NOTICE:** Over application of torque may cause damage to the valve or cap.

8. If required, re-install drain valve with Loctite 567 following method described earlier in this bulletin. Follow Loctite handling precautions as noted on the product labeling.
9. If Loctite 567 is unavailable, we recommend RectorSeal No. 5 pipe thread sealant for all non-glycol based applications, or any PTFE thread sealing tape. Be sure to follow the manufacturer specific handling precautions and application instructions as noted on the product labeling.

### HOW TO USE PRESSURE TAPS TO MEASURE SYSTEM OPERATING CONDITIONS

1. Using Bell & Gossett Model RP-250B readout probes, attach a Bell & Gossett differential pressure readout kit to the readout valves on the desired valve.



**WARNING:** Hot water leakage can occur from readout valves (P/T ports) during probe insertion and during hookup of readout kit. Follow the instruction manuals supplied with readout probes and readout kits for safe use. Failure to follow these instructions could result in serious personal injury or death and property damage.

2. Read the differential pressure across the coil. This can be compared to system pump head to determine system flow blockage.
3. Differential pressure can also be taken at Circuit Setter, Circuit Sentry, Ultra Setter, Flo-Setter, or Low Flow valves.

### PIPE HANGING INSTALLATIONS

Be aware of water weight in the valve and connected piping when installing your system.



**NOTICE:** Never use the valve itself as a form of piping support. Please support valves and piping according to the local building code. Failure to follow these instructions may result in property damage.

## MC CIRCUIT SETTER VALVES

### DESCRIPTION

Bell & Gossett Circuit Setter Valves are precision engineered valves used in heating and cooling systems which function as precise system balancing valves and highly accurate variable orifice flow meters.

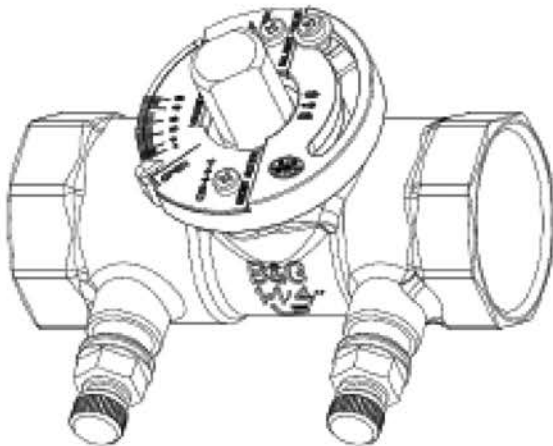

## INSTALLATION INSTRUCTIONS

The valve should be installed on the return side of the coil with union end on the upstream side and other end on the downstream side, except when used on the bypass line.

### HOW TO USE BELL & GOSSETT CIRCUIT SETTER BALANCE VALVES FOR PRE-SET FLOW BALANCING

All Circuit Setter balance valves within a common zone, circuit, or system, with a common pump, are brought into balance with each other by establishing a common BALANCE GOVERNING HEAD LOSS as noted.



**CAUTION:** Hot un-insulated surfaces can cause burns to the skin. Do not touch hot surfaces. Failure to follow these instructions could result in personal injury.

1. Identify the zone within a given circuit or circuit within a given system with the highest head loss.
2. Establish the value of the head loss in feet of water.
3. Establish the corresponding required GPM.
4. Select the appropriate size Circuit Setter balance valve (normally line size) for the required GPM.
5. Using Side #1 of the V91483 Circuit Setter Balance Valve Calculator, set the degree of closure hairline in the red section of the Calculator over the 0° setting for the appropriate size Circuit Setter and read the head loss opposite the required GPM. The setting for this Circuit Setter will remain 0°.
6. Add the head loss in Step #5 to the head loss in Step #2 to establish the Balancing Governing Head Loss for the zone or circuit.
7. Subtract the required head loss for each zone circuit from the Balance Governing Head Loss in Step #6 to establish the head loss difference for each zone or circuit which is to be brought into balance with Step #6.
8. The head loss difference in Step #7 and the required GPM in Step #3 are lined up in the white section of Side #1 of the Calculator and the degree of closure for the specific Circuit Setter balance valve is shown under the degree of closure hairline in the red section of the Calculator for the appropriate size Circuit Setter.
9. Adjust the Circuit Setter by turning the red knob by hand on sizes 1/2" thru 1" or by placing a wrench on the wrench flats provided on sizes 1-1/4" thru 3" to set the position determined by the preceding procedure.



**CAUTION:** It is possible, depending on the age or condition of the stem seal, for some liquid to escape during Circuit Setter adjustment. Do not have eyes or face on a level with the sides of the Circuit Setter. Failure to follow this caution could result in serious personal injury.

### NOTES:

- Head Loss in Steps #6 and #2 are a fixed head requirement the zone, circuit, or system pump, as required must overcome.
- Refer to the G95872 prewired tag packaged with the Circuit Setter balance valve and fill in the appropriate information. Attach the tag to the Circuit Setter for future reference.

## HOW TO USE BELL & GOSSETT CIRCUIT SETTERS TO PROPORTIONALLY BALANCE A SYSTEM

1. Open fully all Circuit Setters on a single pump system.
2. If more than one branch circuit is used, start the balance procedure by reading all of the flows to the units in a branch. Each unit (coil) should have its own Circuit Setter for flow balancing. Using Bell & Gossett RP-250B readout probes, sequentially attach a Bell & Gossett differential pressure readout kit to the readout valves (P/T ports) on each Circuit Setter balance valve.

 **WARNING:** Hot water leakage can occur from readout valves (P/T ports) during probe insertion and during hookup of readout kit. Follow the instruction manuals supplied with readout probes and readout kits for safe use. Failure to follow these instructions could result in serious personal injury or death and property damage.

3. Using Side #2 of the Bell & Gossett Circuit Setter Balance Valve Calculator (V91483), with the top hairline set on zero for the size Circuit Setter being read, read the flow corresponding to the pressure drop read with the readout kit.
4. Calculate the ratio of the actual flow to the design flow for each unit in the branch. This is the proportional flow rate. (Actual flow divided by design flow).
5. Select the Circuit Setter with the lowest proportional flow rate. This Circuit Setter is left in the full open position. Every other Circuit Setter in the branch is then reset to the same proportional flow rate.
6. If there are additional branches, repeat the Steps #3, #4, and #5 above for each branch.
7. After all branches have been proportionally balanced, measure the full open flows on the Circuit Setters installed on the risers. Calculate the proportional ratio of each riser Circuit Setter and select the one with the lowest proportional ratio. This Circuit Setter is left fully open and the other riser Circuit Setters are adjusted to this same ratio as described in Step #5 above.
8. Adjust pump flow so that circuits are receiving their design flow. This can be accomplished by adjusting a Circuit Setter balance valve installed on the pump discharge or by changing the pump impeller size.

 **NOTICE:** If a high degree of throttling of flow at pump discharge is required, Bell & Gossett recommends that the pump impeller be sized to produce design flow. This will reduce electrical energy consumption

## HOW TO USE BELL & GOSSETT CIRCUIT SETTER BALANCE VALVES AS FLOW METERS

1. Energize the zone, circuit, and/or system pump(s) as applicable.
2. Using Bell & Gossett Model RP-250B Readout Probes, sequentially attach a Bell & Gossett differential pressure readout kit to the readout valves on each Circuit Setter Balance Valve.

 **WARNING:** Hot water leakage can occur from readout valves (P/T ports) during probe insertion and during hookup of readout kit. Follow the instruction manuals supplied with readout probes and readout kits for safe use. Failure to follow these instructions could result in serious personal injury or death and property damage.

3. Read the differential pressure across the orifice of the Circuit Setter balance valve.
4. Using Side #2 of the Circuit Setter Balance Valve Calculator (V91483), set the hairline over the degree of closure as indicated by the part of the red plastic knob or indicator plate parallel to the degree of closure noted on the calibration plate, and read actual GPM flowing through the Circuit Setter opposite the gauge reading head loss noted in the white section of Side #2.

### NOTE:

- If the system contains a liquid with a specific gravity and/or viscosity higher or lower than that of water, apply the appropriate correction factor noted in these instructions to obtain the actual GPM for the system liquid.

## HOW TO USE BELL & GOSSETT CIRCUIT SETTER BALANCE VALVES AS AN ISOLATION VALVE

1. Move the adjustment knob or stem until the position indicator aligns with the closed position on the calibration plate.
2. Close the isolation valve on the other side of the equipment to be serviced.
3. Open the drain valve to drain the system between the Circuit Setter and the second isolation valve.

 **WARNING:** Check for proper sealing when using as an isolation valve. If the seat is not sealing properly, liquid will continue to flow from the drain valves. In this case, the Circuit Setter must be isolated from the system and replaced. Failure to follow these instructions could result in serious personal injury or death and property damage.

## HOW TO USE THE MEMORY STOP FEATURE

1. Make the final degree of closure setting.
2. Loosen the memory stop locking screw in the slot on the top of red knob.
3. Slide the memory stop screw in the slot (counter-clockwise for ½" thru 1" sizes and clockwise for 1-1/4" thru 3" sizes) until screw stops.
4. Tighten the memory stop screw.

## SERVICE INSTRUCTIONS

Periodically inspect the Circuit Setter for signs of leakage or corrosion.

 **WARNING:** Corrosion or leakage are indications that the Circuit Setter must be replaced. Failure to follow these instructions could result in serious personal injury or death and property damage.

## INSULATION

Bell & Gossett recommends that insulation be attached to the Circuit Setter after the system has been balanced.

### NOTE:

Tape or other acceptable means should be used to secure the insulation to the Circuit Setter balance valve.

## AC CIRCUIT SENTRY AUTOMATIC FLOW LIMITING VALVES



### DESCRIPTION

Bell & Gossett Circuit Sentry automatic flow limiting valves are designed to automatically control the flow in piping system to selected preset limit. As pressure differential increases, a cartridge inside the valve body reduces the flow area to accurately maintain the preselected flow rate.

**NOTICE:** This product is not intended for use in open systems. An open system is one that is exposed to atmospheric pressure at any point, such as a cooling tower system.

### INSTALLATION INSTRUCTIONS

1. The valve should be installed on the return side of the coil with union end on the upstream side and other end on the downstream side, except when used on the bypass line.
2. Install the unit so that the flow arrow on the body housing points in the direction of flow.

### OPERATING INSTRUCTIONS

Operation of the Circuit Sentry automatic flow limiting valve is fully automatic and does not require any adjustment. It automatically maintains the selected flow over the designed differential pressure range.

Before system start up, remove cartridge from the valve. Flush the Hydronic system and reassemble cartridge into the valve and make sure cap is tightened properly per the specifications listed above.

**CAUTION:** Hot un-insulated surfaces can cause burns to the skin. Do not touch hot surfaces. Failure to follow these instructions could result in personal injury.

### HOW TO USE BELL & GOSSETT CIRCUIT SENTRY FLOW LIMITING VALVE PRESSURE TAPS TO DETERMINE PROPER FUNCTIONING OF VALVE

1. Using Bell & Gossett Model PR-250B readout probes, attach a Bell & Gossett differential pressure readout kit to the P/T readout valves on the Circuit Sentry automatic flow limiting valve.

**WARNING:** Hot water leakage can occur from readout valves (P/T ports) during probe insertion and during hookup of readout kit. Follow the instruction manuals supplied with readout probes and readout kits for safe use. Failure to follow these instructions could result in serious personal injury or death and property damage.

2. Read the differential pressure across the Circuit Sentry. This can be compared to system pump head to determine valve function and system flow blockage.

### SERVICE INSTRUCTIONS

Should the Circuit Sentry automatic flow limiting valve require cleaning or changing the orifice, please follow the instructions below.

**CAUTION:** Installation and maintenance must be performed by a qualified professional. Service should not be performed on any valve in an active Hydronic loop. Before attempting to make any required adjustments, properly isolate and drain the branch loops that require service and allow the valves to reach a safe handling temperature (below 100°F [38°C]) and zero pressure condition. Use proper safety equipment including gloves, goggles, or similar tools to avoid contact with system fluids and common hazards. Failure to follow these instructions could result in personal injury and property damage.

1. Loosen and remove the cap from the valve body.
2. Pull the cartridge assembly from the valve body for cleaning or replacing with a new flow cartridge. Check the cartridge by pushing the orifice washer into the cartridge housing several times to make sure the spring is functional.
3. To change the orifice washer for a different flow rate, remove the clip ring from inside the cartridge housing with a screwdriver. Pull the orifice washer out and replace with the new orifice size as required.
4. Reinstall retaining clip ring in the cartridge housing groove. Replace the clip ring if it has been damaged. Slide the cartridge into the valve body. Reassemble the cap with the o-ring to the body following the procedures listed above.

Periodically inspect the Circuit Setter for signs of leakage or corrosion.

**WARNING:** Corrosion or leakage are indications that the Circuit Setter must be replaced. Failure to follow these instructions could result in serious personal injury or death and property damage.

### INSULATION

Bell & Gossett recommends that insulation be attached to the Circuit Sentry after the system has been balanced.

#### NOTE:

Tape or other acceptable means should be used to secure the insulation to the Circuit Sentry balance valve.

## ACL LOW FLOW CIRCUIT SENTRY VALVE



### DESCRIPTION

Low Flow Circuit Sentry Model ACL valve is designed to automatically control the flow in piping systems to a selected preset limit. As pressure differential increases, a cartridge inside the valve body reduces the flow area to accurately maintain the preselected flow rate.

Flow Operating Range: 0.25 – 3.8 GPM

**NOTICE:** This product is not intended for use in open systems. An open system is one that is exposed to atmospheric pressure at any point, such as a cooling tower system.

### INSTALLATION INSTRUCTIONS

Low Flow Circuit Sentry Model ACL Flow Limiting Valves are uni-directional valves and can be installed in most attitudes; Low Flow Circuit Sentry valves should be mounted in the return pipe where temperatures are lower and where the sealing gland is less affected by strain. Installation of strainers and isolation ball valves is recommended. Be sure to install the Low Flow Circuit Sentry ACL valve with the arrow pointing in the direction of flow. Provide enough space around the valve to ensure the flow cartridge can be removed for flow adjustment or system commissioning.

### LOW FLOW CIRCUIT SENTRY MODEL ACL VALVES WITH SWEAT CONNECTIONS

For installing sweat connections, make sure that the flow limiting cartridge has not yet been installed in the valve. When confirmed, proceed as follows:

- Clean tube ends and valve connections thoroughly per good piping practices with a fine grade emery cloth or fine grit sandpaper.
- For soldering, use 95-5 (Tin-Antimony) solder and a good grade of flux.
- Use a torch with a sharp pointed flame.
- When sweating the joints, adjust the valve to the full open position, then wrap the valve with a cool wet rag and then direct the flame with care to avoid subjecting the valve to excessive heat. Allow the valve to cool before touching or operating.
- Check the soldered connection for leaks.

**CAUTION:** Use of improper procedures to sweat valve model with union connection into system can damage valve. Before installing sweat union connection to valve, remove the union nut and O-ring from the valve body, then union tailpiece with union nut must be sweated (soldered) into place. Failure to follow this instruction could result in property damage and/or moderate personal injury.

**CAUTION:** Heat associated with the use of silver solder may damage valve components and void the product warranty. Do not use silver solder. Failure to follow these instructions could result in property damage and/or moderate personal injury.

**CAUTION:** Excessive use of solder or flux may result in damage to the shutoff valve seat and ball. Do not use excessive solder or flux. Failure to follow these instructions can result in moderate personal injury and/or property damage.

### LOW FLOW CIRCUIT SENTRY MODEL ACL VALVES WITH NPT CONNECTIONS

Apply pipe compound conservatively to male connecting fittings only. After installation, check all joints for leakage and re-tighten if necessary.

**CAUTION:** The use of PTFE impregnated pipe compound and PTFE tape on pipe threads provides lubricity. Care should be taken to prevent over tightening which may damage the valve body. Failure to follow these instructions can result in personal injury and/or property damage.

### LOW FLOW CIRCUIT SENTRY MODEL ACL VALVES FLOW LIMITING CARTRIDGE INSTALLATION

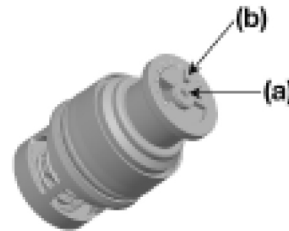

Prior to coil commissioning and operating the Flow Limiting Valve, adjust cartridge to the desired flow rate between 0.25 GPM to 3.8 GPM.

- Loosen screw (a) position.
- Rotate plastic dial (b) to the desired flow rate. Increments marked on variable orifice are in GPM.
- Re-tighten screw (a) with dial set at the desired flow rate.
- Install the cartridge as shown below.

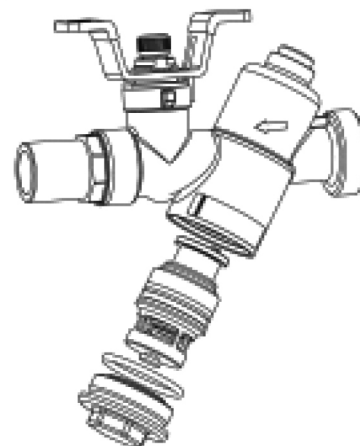





**CAUTION:** Make sure Valve Cap is properly assembled. Failure to follow these instructions can result in personal injury and/or property damage.

## OPERATION INSTRUCTIONS

### HOW TO USE BELL & GOSSETT LOW FLOW CIRCUIT SENTRY MODEL ACL FLOW LIMITING VALVES FOR PRE-SET FLOW BALANCING

Operation of the Flow Limiting Valve is fully automatic. It automatically maintains the selected flow over the designed differential pressure range.



**CAUTION:** Hot un-insulated surfaces can cause burns to the skin. Do not touch hot surfaces. Failure to follow these instructions could result in personal injury.

Before system start up, remove the flow limiting cartridge from the valve, if previously installed. Flush the hydronic system as part of commissioning and then reassemble cartridge into the valve. Make sure the valve cap is tightened properly. Start the system and inspect the Low Flow Circuit Sentry ACL valve for leakage.

### HOW TO USE PRESSURE TAPS (P/T PORTS) TO MEASURE SYSTEM OPERATING CONDITIONS

Using Bell & Gossett Model RP-250B, readout probes, attach Bell & Gossett differential pressure readout kit to the readout valves (P/T ports) on the Low Flow Circuit Sentry ACL valve.



**WARNING:** Hot water leakage can occur from readout valves (P/T ports) during probe insertion and during hookup of readout kit. Follow the instruction manuals supplied with readout probes and readout kits for safe use. Failure to follow these instructions could result in serious personal injury or death and property damage.

Read the differential pressure from the coil inlet isolation valve (typically strainer) to coil outlet isolation valve (typically flow limiting balancing valve). Differential value should be between the sum of the coil and control valve pressure drop and 60 psi, depending upon the amount of control being exercised by the flow limiting valve function for balance. An optional pressure readout valve (B&G P/N V58050) may be installed in the barrel above the cartridge chamber of the flow limiting valve of the coil for a more discrete reading if desired. Valves should be installed with coil and barrels isolated and drained.

## SERVICE INSTRUCTIONS

Periodically inspect the Low Flow Circuit Sentry Model ACL Flow Limiting Valve for signs of leakage or corrosion.



**WARNING:** Corrosion or leakage are indications that the Low Flow Circuit Sentry Model ACL Flow Limiting Valve must be replaced. Failure to follow these instructions could result in serious personal injury or death and property damage.

Due to the different types of material used, the Low Flow Circuit Sentry Model ACL Flow Limiting Valve must be disassembled prior to disposal. Special handling of certain valve components may be required by law or may be sensible from an ecological point of view.

Should the Flow Limiting Valve require cleaning or changing the flow rate, follow the instructions below:

1. Loosen and remove the cap from the valve body.
2. Pull the cartridge assembly from the valve body for cleaning or flow adjustment.
3. Check the cartridge by pushing the orifice washer into the cartridge housing several times to make sure spring is functional and to dislodge any possible debris. Rinse with water if necessary.
4. Once clean, return flow cartridge to valve following installation instructions above.
5. Replace with a new flow cartridge (V58564) if necessary. Tighten cartridge cap per instructions in section above.

## INSULATION

Bell & Gossett recommends that insulation be attached to the Low Flow Circuit Sentry Model ACL Flow Limiting Valve after the system has been balanced.

### NOTE:

Tape or other acceptable means should be used to secure the insulation to the Low Flow Circuit Sentry Model ACL Flow Limiting Valve.

## AM CIRCUIT SENTRY FLO-SETTER BALANCE & COMMISSIONING VALVES

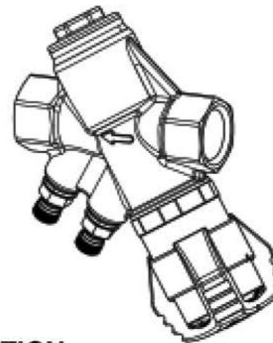

## DESCRIPTION

Bell & Gossett Circuit Sentry Flo-Setter Balance & Commissioning Valves are precision engineered valves used in closed heating and cooling systems for the distribution of flow in various sections of the system. The dynamic balancing and commissioning valve ensures easy and reliable balancing of the system, regardless of any fluctuations in the differential pressure of the system. The Bell & Gossett Circuit Sentry Flo-Setter limits the maximum flow in the system and can be used in both variable and constant flow systems. The clear scale on the lockable handle ensures that flow setting is simple and user friendly while the integral P/T ports allow verification of pressure.



**NOTICE:** This product is not intended for use in open systems. An open system is one that is exposed to atmospheric pressure at any point, such as a cooling tower system.

## INSTALLATION INSTRUCTIONS

Circuit Sentry Flo-Setter Balance & Commissioning Valves are uni-directional valves and can be installed in most attitudes; however, they should be installed in a position to facilitate the ease of balancing the system. Be sure to install the Circuit Sentry Flo-Setter with the arrow pointing in the direction of flow.

## CIRCUIT SENTRY FLO-SETTER BALANCE VALVES WITH NPT CONNECTIONS

Apply pipe compound conservatively to male connecting fittings only.

**CAUTION:** The use of PTFE impregnated pipe compound and PTFE tape on threads provides lubricity. Care should be taken to prevent over tightening of the valves which may damage the Circuit Sentry Flo-Setter.

Check connections for leaks.

### OPERATION INSTRUCTIONS

#### HOW TO USE BELL & GOSSETT CIRCUIT SENTRY FLO-SETTER BALANCE & COMMISSIONING VALVES FOR PRE-SET FLOW BALANCING

The Circuit Sentry Flo-Setter Balance & Commissioning Valve is easily set, and the pre-setting is read on the scale.

Select the appropriate size Circuit Sentry Flo-Setter Balance & Commissioning Valve (normally line size) for the required GPM.

Please note: The scale is for the adjustment of flow. If you want to close the branch line, use an isolation ball valve in conjunction with the Circuit Sentry Flo-Setter.

The handle can be locked after adjustment. Remove the B&G logo cap and tighten with 5mm hexagonal key.

#### HOW TO USE BELL & GOSSETT CIRCUIT SENTRY FLO-SETTER TO PROPORTIONAL BALANCE A SYSTEM

The system is easily balanced by adjusting the pump according to the required differential pressure across the critical valve.

When the differential pressure is available the system will automatically be balanced.

**WARNING:** Hot water leakage can occur from readout valves (P/T ports) during probe insertion and during hookup of readout kit. Follow the instruction manuals supplied with readout probes and readout kits for safe use. Failure to follow these instructions could result in serious personal injury or death and property damage.

### SERVICE INSTRUCTIONS

Periodically inspect the Circuit Sentry Flo-Setter for signs of leakage or corrosion.

**WARNING:** Corrosion or leakage are indications that the Circuit Sentry Flo-Setter must be replaced. Failure to follow these instructions could result in serious personal injury or death and property damage.

### INSULATION

Bell & Gossett recommends that insulation be attached to the Circuit Sentry Flo-Setter after the system has been balanced.

#### NOTE:

Tape or other acceptable means should be used to secure the insulation to the Circuit Sentry Flo-Setter Balance & Commissioning Valve.

## AA ULTRA SETTER PRESSURE INDEPENDENT CONTROL VALVES

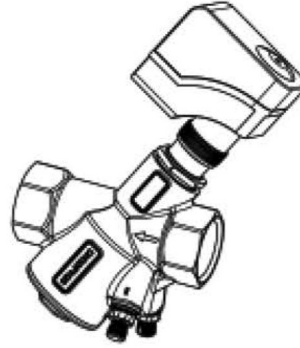

### DESCRIPTION

The Bell & Gossett Ultra Setter is a pressure independent electrically actuated combination temperature control, balance, and commissioning valve for use in closed HVAC systems. It features an internal automatic balancing cartridge that works in conjunction with the external modulating control actuator to ensure proper flow through the system. This results in less required installation and commissioning time and allows for greater system flexibility and more accurate control. Valves come with a choice of 0-10 VDC Analog or 3-Position Tri-State actuator and are equipped with two capped 1/4" readout valves and feature Threaded NPT end connections.

**NOTICE:** This product is not intended for use in open systems. An open system is one that is exposed to atmospheric pressure at any point, such as a cooling tower system.

The Ultra Setter Pressure Independent Control Valve is unaffected by the angle of installation in the piping system. The actuator should never be positioned below the horizontal axis of the pipe. If installed in vertical pipes the valve must be positioned with the actuator upwards. Minimum 8 inches (200 mm) access space recommended above the actuator and beside the terminal plug.

When mounting the actuator in a plenum, the proper cable must be attached to meet local codes.

Do not use autotransformers.

Use earth-ground isolating, step-down, Class 2, power supplies.

Determine supply transformer rating by summing total VA of all actuators used. Use one transformer to power up to 10 actuators.

Turn the manual-positioning knob on the top of the actuator to "0". The actuators can be driven manually to any position with a 3mm hex wrench. The control signal from the controller, however, will take priority over any manual position.



## INSTALLATION INSTRUCTIONS

Ultra Setter Pressure Independent Control Valves are uni-directional valves and can be installed in most attitudes; Ultra Setter should preferably be mounted in the return pipe where temperatures are lower and where the sealing gland is less affected by strain. Installation of strainers and isolation ball valves is recommended. Be sure to install the Ultra Setter with the arrow pointing in the direction of flow.

The Ultra Setter Pressure Independent Control Valve is unaffected by the angle of installation in the piping system. The actuator should never be positioned below the horizontal axis of the pipe. If installed in vertical pipes the valve must be positioned with the actuator upwards. Minimum 8 inches (200 mm) access space recommended above the actuator and beside the terminal plug.



**WARNING:** If mounting the actuator to a valve already in line, either close the shut-off valves in the piping (upstream first, then downstream) or switch off the pump to allow the differential pressure in the valve to drop.

When mounting the actuator in a plenum, the proper cable must be attached to meet local codes.

Do not use autotransformers.

Use earth-ground isolating, step-down, Class 2, power supplies.

Determine supply transformer rating by summing total VA of all actuators used. Use one transformer to power up to 10 actuators.

Turn the manual-positioning knob on the top of the actuator to "0". The actuators can be driven manually to any position with a 3mm hex wrench. The control signal from the controller, however, will take priority over any manual position.

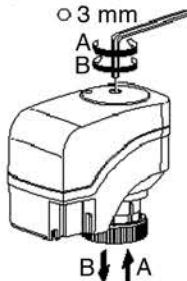

### ULTRA SETTER PRESSURE INDEPENDENT CONTROL VALVES WITH NPT CONNECTIONS

Apply pipe compound conservatively to male connecting fittings only.

Check connections for leaks.

**CAUTION:** The use of PTFE impregnated pipe compound and PTFE tape on threads provides lubricity. Care should be taken to prevent over tightening of the valves which may damage the Ultra Setter.

### ULTRA SETTER PRESSURE INDEPENDENT CONTROL VALVES WITH 0-10 VDC ANALOG ACTUATOR

Attach the wires to the terminal plug.

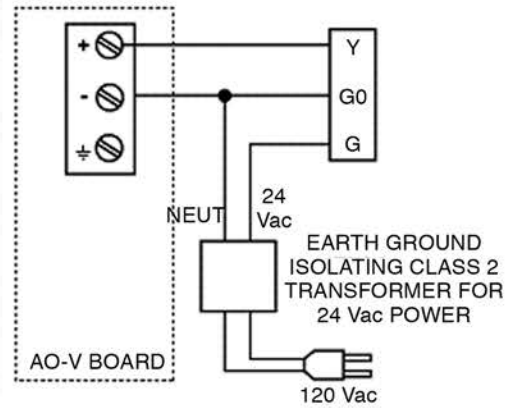

Standard Symbol	Function	Terminal Connection
1	Supply (SP)	G
2	System neutral	G0
8	Control signal	Y

**NOTICE:** Wire connection G is 24 VAC HOT on the SSD61 actuator (V59062), not neutral. G0 and G must be properly wired for correct function and full life of the actuator.

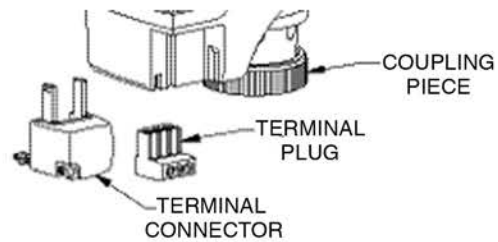

Insert the terminal plug into the terminal connector or optional conduit connector.



Place the connector and plug into the actuator, fitting the nut into the recess in the bottom of the actuator.

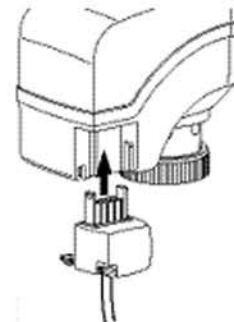

Tighten the screw to hold the connector in place.

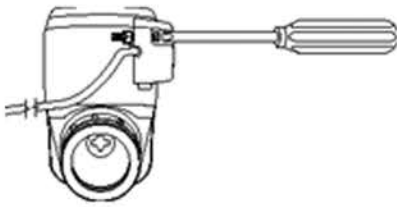

Place the actuator on the valve and firmly hand-tighten the coupling.

The stroke travel is proportional to control signal Y. A zero voltage control signal retracts the stroke and returns the valve to its normal position. With no supply voltage, the actuator maintains its last position.

The SSD61 (V59062) is equipped with a microprocessor to control the valve stroke length. The actuator will complete a calibration stroke each time the power supply voltage is connected.

Do not attempt to calibrate an actuator if it is not attached to a valve. In this situation, the actuator will make three attempts to calibrate, and then will hold at the full stroke position. To calibrate the actuator, remove power, manually return the actuator to the 0 stroke position, attach it to a valve, and then apply power.

**ULTRA SETTER PRESSURE INDEPENDENT CONTROL VALVES WITH 24 VAC 3-POSITION ACTUATOR**

Attach the wires to the terminal plug.

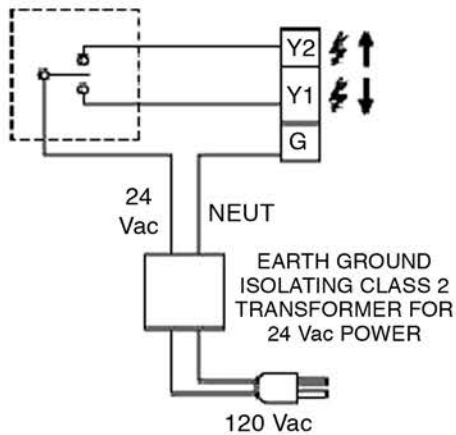

Standard Symbol	Function	Terminal Connection
1	Supply (SP)	G
6	Control signal: Outward movement of the actuator output shaft	Y1
7	Control signal: Inward movement of the actuator output shaft	Y2

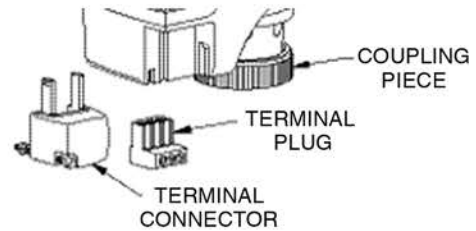

Insert the terminal plug into the terminal connector or optional conduit connector.



Place the connector and plug into the actuator, fitting the nut into the recess in the bottom of the actuator.

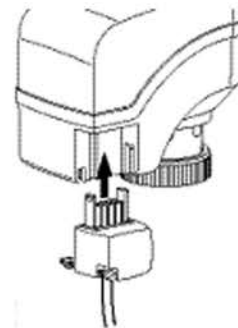

Tighten the screw to hold the connector in place.

Place the actuator on the valve and firmly hand-tighten the coupling.

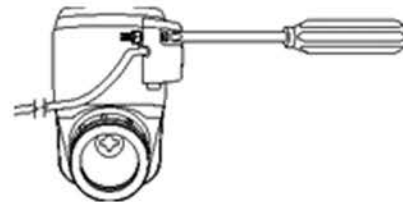

A 24 VAC control signal to the Y1 extends the actuator output shaft.

A 24 VAC control signal to the Y2 retracts the actuator output shaft.

The stroke travel is proportional to the length of time the signal is applied. With no control voltage or in the event of a power failure, the actuator maintains its last position.

Do not attempt to operate an actuator if it is not attached to a valve. In this situation, the actuator will only respond to a signal on terminal Y1, and drive to the full stroke position. It will then hold at the full stroke position. Only by attaching the actuator to a valve, or by manually depressing the actuator stem to engage an internal micro-switch, will the actuator respond to a signal on terminal Y2.

## OPERATION INSTRUCTIONS

### HOW TO USE BELL & GOSSETT ULTRA SETTER PRESSURE INDEPENDENT CONTROL VALVES FOR PRE-SET FLOW BALANCING

The innovative design of the Bell & Gossett Ultra Setter introduces a modulating control component that retains 100% authority at all times. With the Ultra Setter, there are two independent movements for the presetting and the modulating function. During presetting, the inlet area moves radially without interfering with the length of the stroke. During modulating, the inlet area moves linearly taking advantage of the full stroke.

While the actuator provides proportional modulation irrespective of the preset flow, the automatic balancing cartridge guarantees that the flow will never exceed the maximum preset flow. Regardless of pressure fluctuations in the system, the maximum flow is kept constant up to a maximum differential pressure of 60 PSI (400kPa).

The flow rate of the valve can be determined from the flow rate setting on the valve dial. See the flow rate graphs of the valve in the FLOW CURVE BOOK (G10093) or Submittal (A-609.21 or A-610) for further information about the adjustment setting.

Select the appropriate size Ultra Setter Pressure Independent Control Valve (normally line size) for the required GPM. Ideally, Ultra Setter valves should be selected such that they operate at about 80% of their maximum flow, enabling them to deliver spare capacity, if required.

Please note: The scale is for the adjustment of flow. If you want to close the branch line, use an isolation ball valve in conjunction with the Ultra Setter.

Before installing actuator, remove the protective cover from the valve stem.



Loosen knurled nut.



Make the required setting and retighten knurled nut by hand. Place the actuator on the valve and firmly hand-tighten the coupling.

### HOW TO USE BELL & GOSSETT ULTRA SETTER TO COMMISSION A SYSTEM



Each Ultra Setter valve can be set independently and in any order provided there is sufficient pressure available to enable its integral differential pressure control cartridge to operate.

Branches close to the pump are most likely to have sufficient pressure at start up and are therefore an obvious place to start.

For the selected Ultra Setter valve, ensure that the 2 port valve is fully open. Measure the pressure differential across readout valves (P/T ports) and confirm that the value obtained is greater than the minimum value indicated in the FLOW CURVE BOOK or Submittal. If this is not the case investigate the causes and, if necessary, report to the designer.

Adjust the flow setting dial to the specified design flow rate. Lock the dial in position and record the setting.

Repeat the process for all of the Ultra Setter valves on the branch.

Measure the flow rate indicated at the flow measurement device on the branch. Confirm that the value recorded is equal to the sum of the flows set at downstream Ultra Setter valves. If this is not the case investigate the causes and, if necessary, report to the designer.

Repeat this procedure until all Ultra Setter valves in the system have been set and their summated flows checked against upstream flow measurement devices.

Measure the differential pressure across the Ultra Setter valve on the system index terminal (usually the most remote terminal from the pump). Adjust the pump speed until the pressure differential across this valve is equal to the minimum value indicated in the FLOW CURVE BOOK or Submittal.

Determine the pressure differential at the sensor location. Set the pump speed to control such that the value indicated at the sensor is maintained constant under all conditions.

Measure and record the total flow rate, pressure differential and energy consumption at the pump.

Run all two port valves to their closed positions. Measure and record the total flow rate, pressure differential and energy consumption at the pump. Calculate and report the overall energy saving achieved between full load and minimum load operation.



**WARNING:** Hot water leakage can occur from readout valves (P/T ports) during probe insertion and during hookup of readout kit. Follow the instruction manuals supplied with readout probes and readout kits for safe use. Failure to follow these instructions could result in serious personal injury or death and property damage.

### SERVICE INSTRUCTIONS

Periodically inspect the Ultra Setter for signs of leakage or corrosion.



**WARNING:** Corrosion or leakage are indications that the Ultra Setter must be replaced. Failure to follow these instructions could result in serious personal injury or death and property damage.

Due to the different types of material used, the Ultra Setter valve must be disassembled prior to disposal. Special handling of certain valve components may be required by law or may be sensible from an ecological point of view.

### INSULATION

Bell & Gossett recommends that insulation be attached to the Ultra Setter after the system has been balanced.

### NOTE:

Tape or other acceptable means should be used to secure the insulation to the Ultra Setter Pressure Independent Control Valve.

## MV VENTURI/BALL VALVE COMBINATION



### DESCRIPTION

The Bell & Gossett Model MV is a combination calibrated balance, commissioning and positive shutoff valve for use in HVAC systems. An efficient brass venturi design provides accurate flow balancing with minimal system pressure loss. Valves are furnished with two readout valves (pressure and temperature ports), standard port ball valve with memory stop, and a hanging ID tag for commissioning. A variety of end connections are available on both the fixed and union ends. Venturi/Ball valve provides highly accurate flow measurement capabilities.

### INSTALLATION INSTRUCTIONS

The valve should be installed on the return side of the coil with union end on the upstream side and other end on the downstream side, except when used on the bypass line. Install the unit so that the flow arrow on the body housing points in the direction of flow.

### OPERATING INSTRUCTIONS

1. Energize the zone, circuit and/or system pump(s) as applicable.

**CAUTION:** Hot un-insulated surfaces can cause burns to the skin. Do not touch hot surfaces. Failure to follow these instructions could result in personal injury.

2. Using Bell & Gossett Model RP-250B Readout Probes, sequentially attach a Bell & Gossett differential pressure readout kit to the readout valves (P/T ports) on each Venturi/Ball valve.

**WARNING:** Hot water leakage can occur from readout valves (P/T ports) during probe insertion and during hookup of readout kit. Follow the instruction manuals supplied with readout probes and readout kits for safe use. Failure to follow these instructions could result in serious personal injury or death and property damage.

3. Read the differential pressure across the orifice of the Venturi/Ball valve.
4. Use the differential pressure data sheet #EP-600 of the Venturi/Ball valve to read actual GPM.

## HOW TO USE BELL & GOSSETT MV VENTURI/BALL VALVES AS AN ISOLATION VALVE

1. Move the handle until the position indicator aligns with the closed position on the valve.
2. Close the isolation valve on the other side of the equipment to be serviced.
3. Open the drain valve to drain the system between the Venturi/Ball valve and the second isolation valve.

**WARNING:** Check for proper sealing when using as an isolation valve. If the seat is not sealed properly, liquid will continue to flow from the drain valves. In this case, the MV Venturi/Ball valve must be isolated from the system and replaced. Failure to follow these instructions could result in serious personal injury or death and property damage.

### HOW TO USE THE MEMORY STOP FEATURE

1. Make the final degree of closure setting.
2. Loosen the handle nut and rotate memory stop until against the body locking.
3. Tighten the handle nut.

### SERVICE INSTRUCTIONS

Periodically inspect the MV Venturi/Ball valve for signs of leakage or corrosion.

**WARNING:** Corrosion or leakage are indications that the MV Venturi/Ball valve must be replaced. Failure to follow these instructions could result in serious personal injury or death and property damage.

### INSULATION

Bell & Gossett recommends that insulation be attached to the Venturi/Ball valve after the system has been balanced.

#### NOTE:

Tape or other acceptable means should be used to secure the insulation to the Venturi/Ball valve.

## UBY Y-STRAINER COMBINATION BALL VALVE



### DESCRIPTION

Y-strainer valves are of brass construction with an integrated ball valve, strainer, blow-down drain valve, and union with tail-piece.

### INSTALLATION INSTRUCTIONS

1. The valves must be installed on the supply side of the coil with fixed end on the upstream side and other end on the downstream side.
2. When installing the Y-strainer valves, space around the units must be provided to move the valve handle to the shutoff position and to remove the strainer from the strainer body for cleaning.
3. The Y-strainer must be installed with the strainer chamber down to prevent air binding and also to allow accumulated dirt to be blown down from the strainer.

### OPERATING INSTRUCTIONS

The Y-strainer can be used to isolate Hydronic equipment for repairs and/or to drain the system. To close the Y-strainer ball valve, move the handle a quarter of a turn until the handle is perpendicular to the valve and piping.

If the Y-strainer pressure drop becomes excessive, accumulated dirt and debris should be blown down through the blow-down line (if installed) to a drain. If a blow-down line is not installed, see the service instructions for removing and cleaning the strainer. The Y-strainers have construction with an integrated ball valve which will function as a service valve.

### SERVICE INSTRUCTIONS

If excessive pressure drop is measured across the Y-strainer, the internal strainer has collected dirt and debris and needs to be cleaned. Install a blow-down line (hose), then open blow-down drain valve. If blowing down the strainer has not solved the pressure drop problem, the Y-strainer must be disassembled and the strainer cleaned.

**CAUTION:** Failure to use proper hose connection to the blow-down drain valve may result in serious personal injury and property damage.

To clean the strainer, isolate the Y-strainer by shutting off the ball valves on the upstream and downstream of the Y-strainer. Allow the system to cool down to 100° F (38° C) or less.

**CAUTION:** Installation and maintenance must be performed by a qualified professional. Service should not be performed on any valve in an active Hydronic loop. Before attempting to make any required adjustments, properly isolate and drain the branch loops that require service and allow the valves to reach a safe handling temperature (below 100° F [38° C]) and zero pressure condition. Use proper safety equipment including gloves, goggles, or similar tools to avoid contact with system fluids and common hazards. Failure to follow these instructions could result in personal injury and property damage.

Using the appropriate sized wrench, remove the blow-down drain valve from the brass strainer cap on the bottom of the valve body. Completely remove the strainer cap from the valve body. Carefully remove the strainer. Clean the strainer in water to remove collected debris. Reinstall the strainer and the strainer cap. Tighten to the appropriate torque level as listed above. Reinstall the blow-down drain valve per instructions above. Pressurize the system and check for leaks.

Periodically inspect the Y-strainer for signs of corrosion or leakage. If corrosion or leakage is noted, the Y-strainer must be replaced.

**WARNING:** Corrosion or leakage are indications that the Y-strainer valve must be replaced. Failure to follow these instructions could result in serious personal injury or death and property damage.

### INSULATION

Bell & Gossett recommends that insulation be attached to the Y-strainer valve after the system has been balanced.

### NOTE:

Tape or other acceptable means should be used to secure the insulation to the Y-Strainer Valve.

## UBYL LOW Y-STRAINER COMBINATION BALL VALVE



### DESCRIPTION

Low Flow Y-strainer Valves are made of brass construction with an integrated ball valve and strainer.

## INSTALLATION INSTRUCTIONS

Model UBYL Low Flow Y-strainer Valves are uni-directional valves and should be mounted in the supply pipe. Be sure to install the Model UBYL Low Flow Y-strainer valve with the arrow pointing in the direction of flow and the strainer chamber down to prevent air binding and to allow materials to collect in the strainer. Be sure to provide enough space around the valve to remove the strainer from the valve body for cleaning.

### LOW FLOW MODEL UBYL Y-STRAINER VALVES WITH SWEAT CONNECTIONS

For installing sweat connections, make sure that the flow limiting cartridge has not yet been installed in the valve. When confirmed, proceed as follows:

- Clean tube ends and valve connections thoroughly per good piping practices with a fine grade emery cloth or fine grit sandpaper.
- For soldering, use 95-5 (Tin-Antimony) solder and a good grade of flux.
- Use a torch with a sharp pointed flame.
- When sweating the joints, adjust the valve to the full open position, then wrap the valve with a cool wet rag and then direct the flame with care to avoid subjecting the valve to excessive heat. Allow the valve to cool before touching or operating.
- Check the soldered connection for leaks.

 **CAUTION:** Use of improper procedures to sweat valve model with union connection into system can damage valve. Before installing sweat union connection to valve, remove the union nut and O-ring from the valve body, then union tailpiece with union nut must be sweated (soldered) into place. Failure to follow this instruction could result in property damage and/or moderate personal injury.

 **CAUTION:** Heat associated with the use of silver solder may damage valve components and void the product warranty. Do not use silver solder. Failure to follow these instructions could result in property damage and/or moderate personal injury.

 **CAUTION:** Excessive use of solder or flux may result in damage to the shutoff valve seat and ball. Do not use excessive solder or flux. Failure to follow these instructions can result in moderate personal injury and/or property damage.

### LOW FLOW MODEL UBYL Y-STRAINER VALVES WITH NPT CONNECTIONS

Apply pipe compound conservatively to male connecting fittings only. After installation, check all joints for leakage and re-tighten if necessary.

 **CAUTION:** The use of PTFE impregnated pipe compound and PTFE tape on pipe threads provides lubricity. Care should be taken to prevent over tightening which may damage the valve body. Failure to follow these instructions can result in personal injury and/or property damage.

## OPERATION INSTRUCTIONS

### HOW TO USE BELL & GOSSETT LOW FLOW MODEL UBYL Y-STRAINER VALVES

Y-strainer can be used to isolate hydronic equipment for repairs and/or to drain the system. To close the Y-strainer ball valve, move the handle a quarter of a turn until the handle is perpendicular to the valve and piping.

 **CAUTION:** Hot un-insulated surfaces can cause burns to the skin. Do not touch hot surfaces. Failure to follow these instructions could result in personal injury.

Before system start up, flush the hydronic system as part of commissioning. Make sure the drain valve cap is tightened properly. Start the system and inspect the Low Flow Model UBYL Y-strainer valve for leakage.

### HOW TO USE PRESSURE TAPS (P/T PORTS) TO MEASURE SYSTEM OPERATING CONDITIONS

Using Bell & Gossett Model RP-250B, readout probes, attach Bell & Gossett differential pressure readout kit to the readout valves (P/T ports) on the Low Flow Model UBYL Y-Strainer Valves.

 **WARNING:** Hot water leakage can occur from readout valves (P/T ports) during probe insertion and during hookup of readout kit. Follow the instruction manuals supplied with readout probes and readout kits for safe use. Failure to follow these instructions could result in serious personal injury or death and property damage.

Read the differential pressure from the coil inlet isolation valve (typically strainer) to coil outlet isolation valve (typically flow limiting balancing valve). Differential value should be between the sum of the coil and control valve pressure drop and 60 psi, depending upon the amount of control being exercised by the flow limiting valve function for balance. Valves should be installed with coil and barrels isolated and drained.

If Y-strainer pressure drop becomes excessive, accumulated dirt and contaminants should be blown through the blow-down line (if installed) to a drain. If a blow-down line is not installed, see the service instructions for removing and cleaning the strainer. The Y-strainers have construction with an integrated ball valve and will function as a service valve.

## SERVICE INSTRUCTIONS

If excessive pressure drop is noted across the Y-Strainer, the internal strainer has most likely collected a lot of dirt or debris and needs to be cleaned. Install blow-down line (hose) to the drain valve on the strainer chamber then open the drain valve. If flushing the strainer at this point has not solved the pressure drop problem, the Y-strainer must be disassembled and strainer to be cleaned.



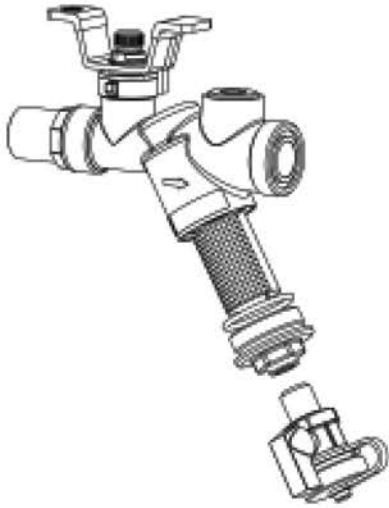

To clean the strainer, isolate the Y-Strainer from the system with the integral ball valve on the upstream side of the strainer. Use an isolation valve downstream of the strainer and coil to further isolate the system. Allow the system to cool to 100°F (38°C) or less before handling. Proceed to drain the isolated system through the drain valve in the Y-Strainer.

**WARNING:** Corrosion or leakage are indications that the Low Flow Model UBYL Y-Strainer Valve must be replaced. Failure to follow these instructions could result in serious personal injury or death and property damage.

Using the appropriate sized wrench, remove the blow-down drain valve from the brass strainer cap on the bottom of the valve body. Completely remove the strainer cap from the valve body. Carefully remove the strainer. Clean the strainer in water to remove collected debris. Reinstall the strainer and the strainer cap. Tighten to the appropriate torque level as listed above. Reinstall the blow-down drain valve per instructions above. Pressurize the system and check for leaks.

**CAUTION:** Make sure Valve Cap is properly assembled. Failure to follow these instructions can result in personal injury and/or property damage.

Periodically inspect the Low Flow Model UBYL Y-Strainer Valve for signs of leakage or corrosion.

**WARNING:** Corrosion or leakage are indications that the Low Flow Model UBYL Y-Strainer Valve must be replaced. Failure to follow these instructions could result in serious personal injury or death and property damage.

**INSULATION**

Bell & Gossett recommends that insulation be attached to Model UBYL Y-Strainer Combination Valve after the system has been balanced.

**NOTE:**

Tape or other acceptable means should be used to secure the insulation to the Model UBYL Y-Strainer Combination Valve.

**UBV UNION-ENDED BALL VALVE**



**DESCRIPTION**

Union-ended ball valves are of brass construction with combination ball valve and union with tailpiece.

**INSTALLATION INSTRUCTIONS**

1. The valves must be installed on the supply side of the coil with fixed end on the upstream side and union end on the downstream side.
2. When installing the union-ended valves, space around the units must be provided to move the valve handle to the shut-off position. The union-ended ball valve will function as a service valve.
3. The union ended ball valve must be installed with the hose-end drain valve facing down.

**OPERATING INSTRUCTIONS**

Union-ended ball valve is a shut-off valve to isolate hydronic equipment for repairs and/or to drain the system. To close the union-ended valve, move the handle a quarter of a turn until the handle is perpendicular to the valve and piping.

To return the union-ended ball valve to the open position, move the handle one quarter of a turn until it is aligned with the valve body and system piping.

**SERVICE INSTRUCTIONS**

To drain the system, first isolate the union-ended valves from the system. Allow the system to cool down to 100° F (38° C) or less.

**CAUTION:** Installation and maintenance must be performed by a qualified professional. Service should not be performed on any valve in an active Hydronic loop. Before attempting to make any required adjustments, properly isolate and drain the branch loops that require service and allow the valves to reach a safe handling temperature (below 100° F [38° C]) and zero pressure condition. Use proper safety equipment including gloves, goggles, or similar tools to avoid contact with system fluids and common hazards. Failure to follow these instructions could result in personal injury and property damage.

**WARNING:** Corrosion or leakage are indications that the UBV Union Ball Valve must be replaced. Failure to follow these instructions could result in serious personal injury or death and property damage.



## UA UNION ACCESSORY

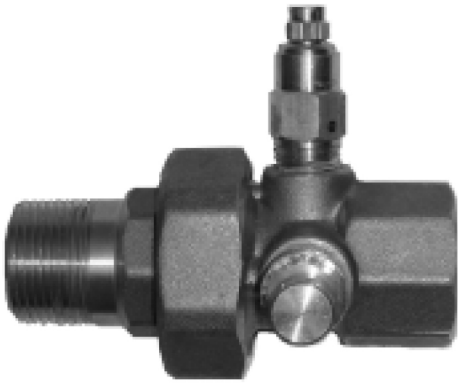

### DESCRIPTION

Accessory hookup union is of brass construction and includes two (2) 1/4" NPT taps which include an air vent (V58051) and P/T readout port (V58050).

### INSTALLATION INSTRUCTIONS

The valves must be installed on the return side of the coil with fixed end on the upstream side and union-end of the downstream side.

Make sure that the air vent (V58051) is facing upward.

### OPERATING INSTRUCTIONS

Accessory valve is for component isolation and installation of accessories.

### SERVICE INSTRUCTIONS

Periodically inspect union accessories for leakage through P/T readout ports and/or manual air vent.

**WARNING:** Corrosion or leakage are indications that the UA Union Accessory must be replaced. Failure to follow these instructions could result in serious personal injury or death and property damage.

## SH HOSE

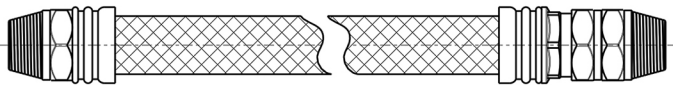

### DESCRIPTION

Hoses are used to offer some flexibility when connecting Bell & Gossett valves with other components in the system. The construction follows the table below:

Hose Size	Material Construction
1/2" - 1-1/4"	STEEL FERRULES AND UL-94 VO FIRE-RATED THERMOPLASTIC INNER TUBE BONDED TO STAINLESS STEEL OUTER BRAID
1-1/2" - 2"	ALL METAL 321 STAINLESS STEEL WITH 304 STAINLESS STEEL BRAID AND CARBON STEEL WELDED FITTINGS

**WARNING:** These hoses are designed for use with water and glycol based fluids in hydronic systems. Do not use hydrocarbon based fluids or other fluids in these hoses. Failure to follow these instructions could result in serious personal injury or death and property damage.

## INSTALLATION INSTRUCTIONS

All hoses must be installed in such a manner that no twisting or kinking occurs. Fittings or elbows should be used where practical to prevent unnecessary twisting, kinking, or strain of the hose. Hoses should be routed so they do not come in contact with corners or other sharp surfaces that may cause flow restriction, smaller than recommended bend radii, cutting, or other damage to the hoses.

Hoses should not be stretched such that they become strained during installation. Hoses can expand and contract due to pressure and temperature variation as the hydronic system cycles and should be sized accordingly.

Solid male NPT ends should be installed first, unless they are being assembled to a female NPT swivel or union connection. The hose must be able to rotate during the tightening of this connection in order to avoid damage. The female swivel end of the hose should then be connected to the corresponding male NPT port.

**WARNING:** Care must be taken to insure that hoses are not exposed to aggressive environmental conditions. Exposure to excessive heat or cold, salt water, chemicals, flux and solder drips, air pollutants, radiation, or other contaminants can cause degradation of the hose and premature failure. Failure to follow these instructions could result in serious personal injury or death and property damage.

**WARNING:** External forces and vibrations applied to installed hoses can significantly reduce product life and cause premature failure. Tensile or side loading should be avoided. Twisting or kinking of the hose will add additional mechanical loading. Failure to follow these instructions could result in serious personal injury or death and property damage.

When installing hoses, slack must be provided. The bend radius must be greater than shown on the table below:

Hose Size	Minimum Bend Radius
1/2"	2.5" (63.5 mm)
3/4"	4" (101.6 mm)
1"	5.5" (139.7 mm)
1-1/4"	10" (254 mm)
1-1/2"	11.75" (298.5 mm)
2"	12.55" (318.8 mm)

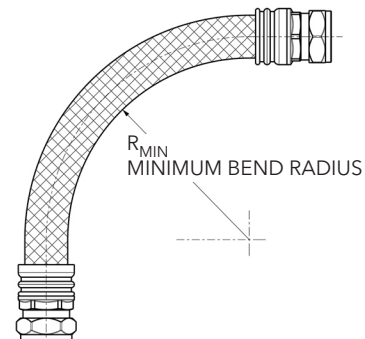

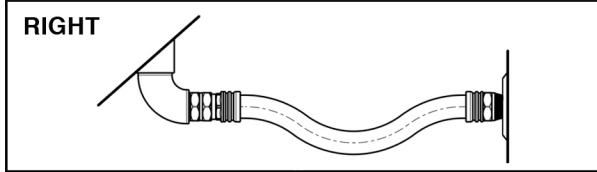
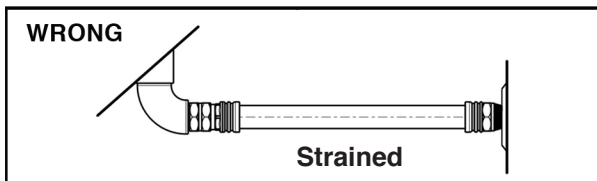
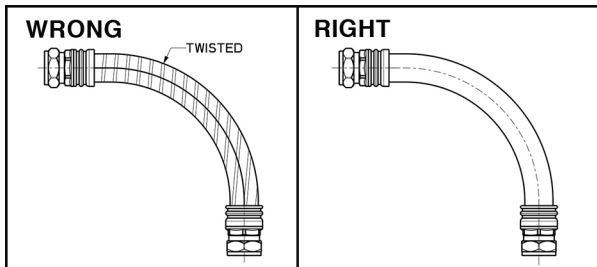
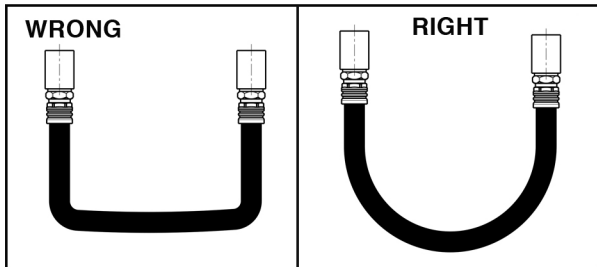
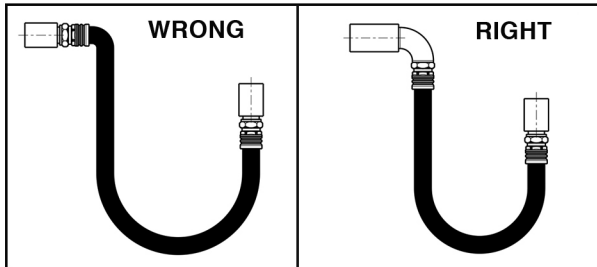
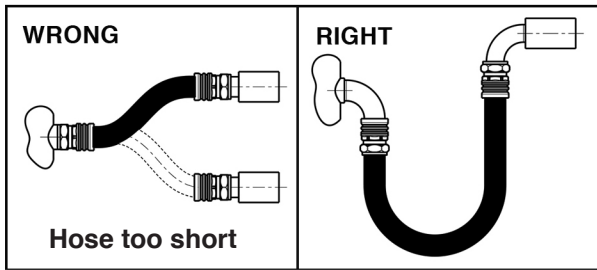

**WARNING:** Hose assemblies may rupture if slack is not provided or the bend radius is smaller than allowed. Make sure that these requirements are provided. Failure to follow these instructions could result in serious personal injury or death and property damage.

Hose must not be twisted while it is being installed. The union joint must be tightened last and it must be held with two wrenches to prevent the hose from twisting.

**NOTE:** When tightening the hose during installation or maintenance, do not hold or clamp the hose by the stainless steel braiding.

**SERVICE INSTRUCTION**

Any field adjustment of factory installed hoses will break the original thread seal and could cause leakage. This will necessitate the removal, cleaning, and resealing of those parts per the instructions below.

Should any servicing of hoses be required, please take the following steps:

1. Completely remove hose from valve or coil.
2. Taking care not to damage any threads on the hose or the valve, clean off all of the old thread sealant. Use a wire brush and gentle abrasion if necessary. Allow the valve and the component to dry. **Note: If the hose or valve appears to have been damaged, replace it.**
3. Starting with the second thread of the NPT male hose end, apply a 360° bead of Loctite 567 thread sealant/lubricant. Follow Loctite handling precautions as noted on the product labeling.
4. If Loctite 567 is unavailable, Bell & Gossett recommends RectorSeal No. 5 pipe thread sealant for all non-glycol based applications, or any PTFE thread sealing tape. Be sure to follow the manufacturer specific handling precautions and application instructions as noted on the product labeling.
5. Thread hose into valve or coil until it is finger tight.
6. Tighten hose to the specification below. Range is given to achieve proper hose alignment.

PIPE CONNECTION	Additional Turns From Finger Tight
1/2" NPT	1 – 1.5
3/4" NPT	1 – 1.5
1" NPT	1 – 1.5
1-1/4" NPT	1 – 1.5
1-1/2" NPT	1 – 1.5
2" NPT	1 – 1.5

**NOTICE:** The use of thread sealants/lubricants on threads also provides lubricity. Over application of torque may cause damage to the hose or valve port.

7. Properly assembled valve components will immediately seal to moderate pressure (100 PSI or less). For maximum pressure resistance, allow the Loctite 567 or RectorSeal No. 5 thread sealant to cure for 24 hours. PTFE tape typically does not require curing to achieve maximum pressure resistance.

Periodically inspect the hose for signs of leakage. If noted, slightly tighten union nut until leakage stops. If leak continues, replace the hose.

**WARNING:** Corrosion or leakage are indications that the SH hose must be replaced. Failure to follow these instructions could result in serious personal injury or death and property damage.

**NOTICE:** Thread sealant should not be used in combination with PTFE thread sealing tape. Using both together can cause leakage and damage the valve or fitting.

\* Loctite and Loctite 567 are registered trademarks of Henkel AG & Co.  
\*\*RectorSeal No. 5 is a registered trademark of RectorSeal Corporation.



Xylem Inc.  
8200 N. Austin Avenue  
Morton Grove, Illinois 60053  
Phone: (847) 966-3700  
Fax: (847) 965-8379  
www.bellgossett.com