

ARMSTRONG

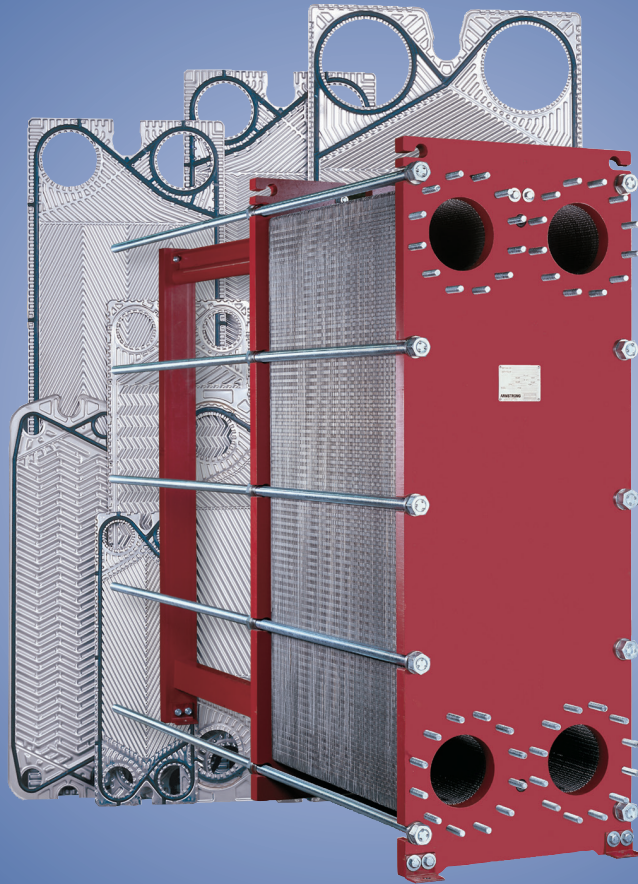
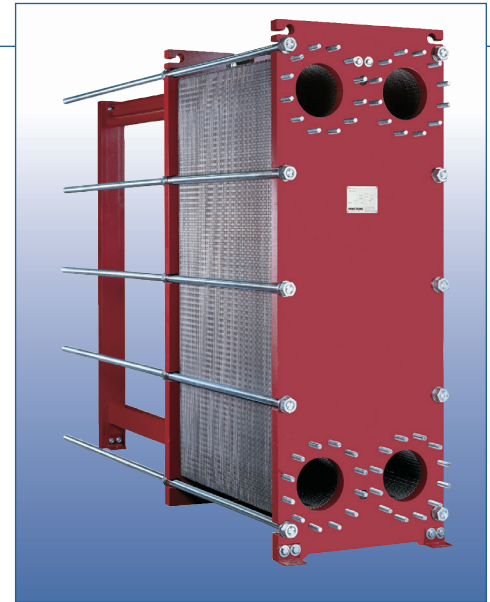

Plate Heat Exchangers

File no:	113.12
Date:	APRIL 11, 2016
Supersedes:	113.12
Date:	AUGUST 25, 2014

Efficient Heat Transfer in a Compact Design

Armstrong's gasketed Plate Heat Exchanger (PHE) product line includes more than 20 different models and offers numerous configurations, connections and material options, providing a superior heat transfer solution for any HVAC application.



Market Challenges

Rising demand for tenant space in commercial buildings and an ever-increasing focus on reducing energy consumption have created numerous challenges for designers and contractors. These challenges include the requirement for mechanical room optimization and energy recovery or free cooling systems such as water-side economizers, geothermal heating/cooling and deep-lake water cooling. There is now, more than ever, a growing demand for compact heat exchangers capable of transferring heat at low approach temperatures to achieve greater temperature crossing, which saves energy.

In addition, factors such as global warming, high frequency of building conversions, and tighter mechanical rooms have led to a demand for heat exchangers that can be maintained easily and are flexible with regards to future expansion.

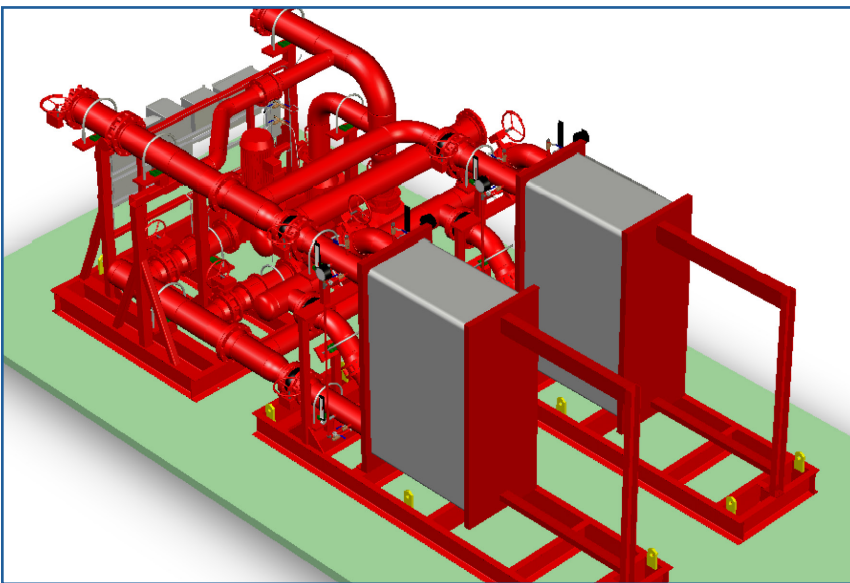

Counter Current Flow & Temperature

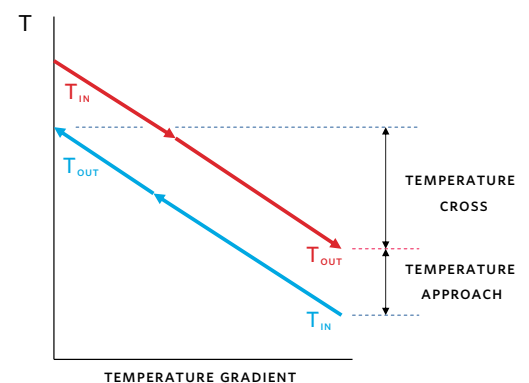
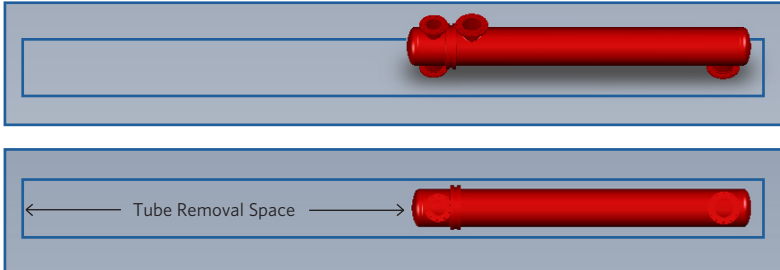

Plate Heat Exchangers

Adding value to hydronic systems

Space savings

Due to their high heat transfer capabilities, Armstrong PHE Series heat exchangers are substantially smaller in size than other heat transfer devices, yet provide the same or better performance. Plate heat exchangers save up to 75% of the floor area, and up to 85% of the floor length required for shell and tube heat exchangers (including area to service the heat exchanger).



Shell & Tube heat exchanger footprint
Space required in feet (metres) = 2.5 (0.76) × 32.3 (9.85) = 80.8 ft² (7.5 m²)
Based on Model W2214

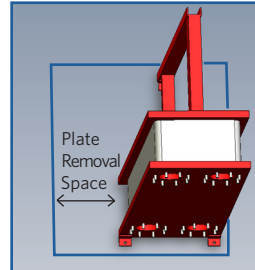

Plate heat exchanger footprint
Space required in feet (metres) = 5.3 (1.60) × 4.7 (1.43) = 24.9 ft² (2.29m²)
Based on Model S106-1250

Project risk minimization

All units are certified for safety by the appropriate agency (i.e. ASME, TSSA, PED, AHRI, etc). Heat transfer plates can be added, replaced or removed easily to maintain or increase the system performance. Gaskets are vented between passages, so there is no cross contamination from a gasket failure. Every unit is provided with a safety shield that surrounds the plates and gaskets. Double-wall heat transfer plates are available for domestic water applications. Select models are available with a design pressure up to 400 psi (24 bar).

Maintenance

Single-pass PHE units are designed with all four system connections on the fixed head. This ensures the unit can be easily maintained without having to break the connecting piping. In addition, plate heat exchangers can be installed in a corner of a mechanical room to optimize the space. When maintenance is required, plates can be removed and installed from one side of the unit. The gaskets are simple to replace and do not require any glue.

Installation advantage

Connections are typically on the same plane for easy piping. Studded flanged connections reduce piping loads on the plate heat exchanger. Units can be certified at the factory and then shipped disassembled for delivery and installation in tight quarters. The vertical piping arrangement (inlet on top and outlet on bottom) of PHE Series units makes them ideal for condensing steam service.

Energy efficiency

The Armstrong PHE series achieves the highest efficiency and heat transfer rates by flowing the two media in opposite directions (counter-current) in a highly turbulent fashion. The temperature gain or loss between the hot fluid and the cold fluid at a given flow rate is the regeneration rate. With counter-current flows, high turbulence and optimized corrugation, Armstrong Series PHE units provide regeneration rates of up to 90%.

$$\% \text{ Regeneration} = (T_{\text{in [hot fluid]}} - T_{\text{out [hot fluid]}}) / (T_{\text{in [hot fluid]}} - T_{\text{in [cold fluid]}}) \times 100$$

The x series plates are specifically designed to produce the highest heat transfer efficiencies.

Armstrong PHE series heat exchangers offer multiple plate geometries to provide the optimum heat transfer solution for a given application.

Occupant Comfort

Armstrong PHE series heat exchangers react quickly to system demand changes, and provide reduced down-time and longer life span due to corrosion resistant materials, anti-scaling effect (due to turbulent flow) and ease of maintenance.

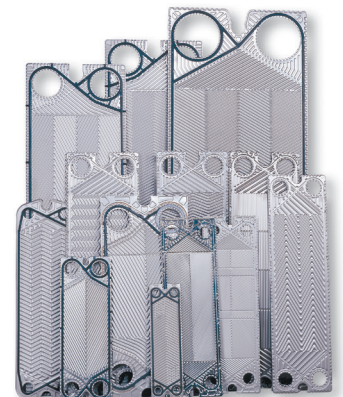

Technical data

FLOW RANGE		Up to 10,550 gpm (630 L/s)
DUTY		Up to 50,000,000 btu/hr (15,000 kW)
MAX. FLUID TEMPERATURE	NITRILE GASKETS	250 °F (120 °C)
	EPDM GASKETS	320 °F (160 °C)
MAX. WORKING PRESSURE		400 psi (2757 kPa, 24 bar)

Materials of construction

PLATES	304 and 316 stainless steel titanium, SMO 254, Hastelloy, Incolloy, Nickel
GASKETS	Nitrile, EPDM, Viton, PTFE

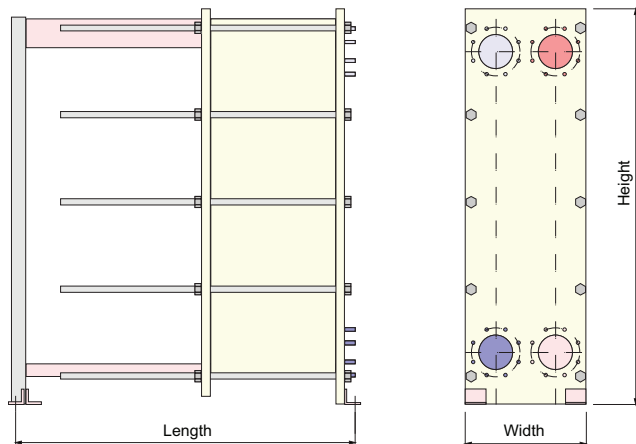

Capacities, dimensions & weights

Model	Max. Flow Rate - gpm (l/s)	Connection Size	Height	Width	Max. Length	Max. Surface Area - ft ² (m ²)	Roller Assembly	Weight	
								Frame	Ea. Plate
M7	60 (3.8)	1.0 (25)	26.0 (660)	8.0 (205)	26.0 (660)	65 (5)	No	115 (50.0)	1 (0.5)
M9	60 (3.8)	1.0 (25)	35.0 (890)	8.0 (205)	35.0 (890)	145 (15)	No	160 (70.0)	1 (0.5)
SX13	250 (15.8)	2.0 (50)	31.0 (790)	14.0 (355)	66.0 (1680)	390 (35)	No	300 (140.0)	2 (0.9)
SX19	250 (15.8)	2.0 (50)	39.0 (990)	14.0 (355)	66.0 (1680)	615 (55)	No	460 (210.0)	2 (0.9)
S26	450 (28.4)	2.5 (65)	48.0 (1220)	15.0 (380)	96.0 (2440)	935 (85)	No	790 (360.0)	5 (2.3)
S36	650 (41.0)	3.0 (75)	55.0 (1400)	17.0 (430)	106.0 (2700)	1325 (125)	No	1300 (590.0)	5 (2.3)
S/SX25	1000 (63.1)	4.0 (100)	44.0 (1120)	21.0 (540)	96.0 (2440)	1490 (140)	No	1070 (480.0)	4 (1.8)
SX29	1000 (63.1)	4.0 (100)	44.0 (1120)	21.0 (540)	96.0 (2440)	1490 (140)	No	1070 (480.0)	4 (1.8)
S/SX35	1000 (63.1)	4.0 (100)	53.0 (1350)	21.0 (540)	96.0 (2440)	2100 (195)	No	1230 (560.0)	5 (2.3)
SX49	1000 (63.1)	4.0 (100)	53.0 (1350)	21.0 (540)	96.0 (2440)	2100 (195)	No	1230 (560.0)	5 (2.3)
S38	1000 (63.1)	4.0 (100)	53.0 (1350)	20.0 (510)	107.0 (2720)	975 (90)	No	1260 (570.0)	5 (2.3)
S/SX55	1000 (63.1)	4.0 (100)	68.0 (1727)	21.0 (540)	96.0 (2440)	3143 (292)	No	1680 (762.0)	7 (3.2)
S/SX56	2200 (138.8)	6.0 (150)	64.0 (1626)	27.0 (685)	168.0 (4270)	2799 (260)	Yes	2139 (970.0)	8 (3.6)
S66	2200 (138.8)	6.0 (150)	76.0 (1930)	24.0 (610)	156.0 (3960)	3910 (365)	Yes	2380 (1070.0)	10 (4.5)
S/SX76	2200 (138.8)	6.0 (150)	78.0 (1980)	27.0 (685)	168.0 (4270)	4420 (410)	Yes	2980 (1340.0)	11 (5.0)
S/SX96	2200 (138.8)	6.0 (150)	93.0 (2360)	27.0 (685)	168.0 (4270)	5890 (545)	Yes	3430 (1550.0)	15 (6.8)
S48	4000 (252.4)	8.0 (200)	63.0 (1600)	30.0 (760)	96.0 (2440)	1490 (135)	Yes	2310 (1040.0)	8 (3.6)
S/SX106	4000 (252.4)	8.0 (200)	90.0 (2300)	34.0 (860)	168.0 (4270)	6300 (585)	Yes	5200 (2340.0)	14 (6.3)
S/SX136	4000 (252.4)	8.0 (200)	106.0 (2700)	34.0 (860)	168.0 (4270)	7850 (730)	Yes	6370 (2870.0)	17 (7.7)
S156	10550 (665.6)	14.0 (350)	103.0 (2620)	45.0 (1145)	168.0 (4270)	10030 (930)	Yes	11630 (5230.0)	17 (7.7)
S229	10550 (665.6)	14.0 (350)	127.0 (3225)	45.0 (1145)	168.0 (4270)	14060 (1305)	Yes	13800 (6210.0)	26 (12.0)

Double-Wall Models									
SX13D	250 (15.8)	2.0 (50)	31.0 (790)	14.0 (355)	66.0 (1680)	290 (25)	No	300 (140.0)	4 (1.8)
SX19D	250 (15.8)	2.0 (50)	39.0 (990)	14.0 (355)	66.0 (1680)	460 (45)	No	460 (210.0)	4 (1.8)
SX25D	1000 (63.1)	4.0 (100)	44.0 (1120)	21.0 (540)	96.0 (2440)	1120 (105)	No	1070 (480.0)	8 (3.6)
SX35D	1000 (63.1)	4.0 (100)	53.0 (1350)	21.0 (540)	96.0 (2440)	1575 (145)	No	1230 (1560.0)	10 (4.6)
S66D	2200 (138.8)	6.0 (150)	76.0 (1930)	24.0 (610)	156.0 (3960)	2930 (270)	Yes	2380 (1070.0)	20 (9.0)

Contact your local representative for information on additional models and capacities.

NOTE:

Dimensions are in inches (mm) and weights in lbs (kg)

Frame weight is based on the maximum frame length, 150 psi (10 bar) design

Dimensions based on 0.6 mm thick plates

Plate Heat Exchangers

Certifications

Safety: ASME, PED, CRN

Performance: AHRI



How it works

The Armstrong PHE series uses robust stainless steel plates (standard construction) as the primary medium for heat transfer. Alternate materials such as SMO 254, a corrosion resistant steel alloy, and titanium are available on request. Each plate is stamped with an optimized corrugated design. The series of plates create alternating independent channels for both the process and service fluids. The two medium circuits are configured to induce true counter-current flow, enabling the heat exchanger to perform at extremely low temperature approaches. This is further improved by using Armstrong x series plates. As each fluid passes through its individual channel, it flows over the 'chevrons' (the corrugated pattern), which increases fluid turbulence, and increases heat transfer through the plates. Heat is transferred from one medium to the other. The Armstrong PHE series uses a gasketed seal to separate the service side from the process side.

Standard connection types

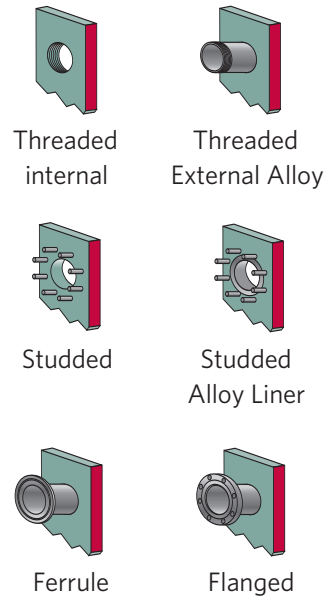

Design features

- 1 All connections are threaded or studded to the cover in order to eliminate nozzle loads caused by the piping.
- 2 Gaskets are double-vented at the port area to eliminate cross contamination of the fluids. Gaskets are attached mechanically to the plate without glue. They attach to the plate only one way, eliminating assembly errors and wasted time during servicing. The gaskets are visible from outside the unit so proper installation is guaranteed.
- 3 Tightening bolts are designed so that all tightening is done from the fixed end (nuts at the moveable end are locked). Bolts are coated for corrosion resistance. This makes servicing the heat exchanger quicker and easier.
- 4 The bars that hold the plates are corrosion resistant for ease of maintenance.
- 5 Heavy duty pressure-retaining headers are designed using the latest stress calculation data, as per ASME and PED, to ensure lengthy and safe service.
- 6 Heat transfer plates are stamped using an H or W pattern according to the application requirements.
- 7 An aluminum safety shield covers the top and sides of the plate pack.

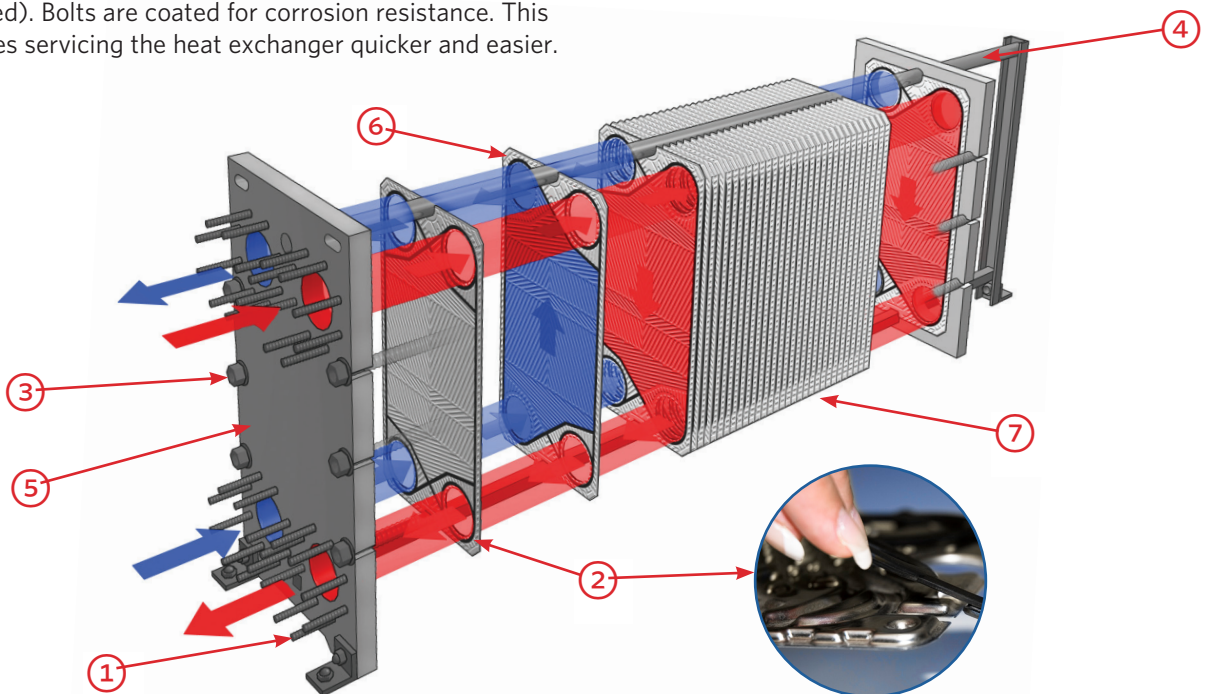

Typical Specifications

- 1.1 Furnish a plate heat exchanger as manufactured and designed by Armstrong completely assembled, inspected and tested to meet the thermal and hydraulic requirements of the schedule.
- 1.2 The heat exchanger design shall be in full accordance with the governing safety code: ASME, TSSA, PED, AHRI.
- 1.3 The individual heat transfer plates that shall be pressed from a single sheet of 304SS, 316SS or titanium with a 2B finish in one step. The plate thickness shall be determined by the manufacturer to meet the design pressures and temperature. The plates shall be provided with a herringbone corrugation with a depth, spacing and thickness to meet a full differential pressure across the plate of 1.3 to 1.5 times the design pressure without deformation or failure.
- 1.4 Each plate shall have a gasket made from nitrile, EPDM or other material that shall be compatible with all the operating fluids and rated for continuous service at the design temperature. The gasket cross section shall be tent shaped, resulting in better sealing with less compressive stress.
- 1.5 Gaskets shall have vent grooves in the unused area of the plate to prevent intermixing of the fluids and to cause any leak by the gasket to be visually evident from outside the heat exchanger. The gasket groove in each plate shall be of the proper depth to contain 100% of the gasket profile.
- 1.6 Gaskets, unless otherwise approved, shall be of the glue-free clip-on type that mechanically attach to a specific U-shaped hole at the outer edge of the plate. Gasket clips shall be visible from the outside to verify proper installation. Glue-free gaskets that wrap around the outer edge of the plate and can be damaged shall not be used. For certain applications, glued on gaskets may be acceptable.
- 1.7 The pressure-retaining frame shall be designed and built to guarantee dependable operation and easy maintenance for the life of the heat exchanger. The frame shall be bolted together for ease of assembly and field installation. The unit covers shall be of sufficient uniform thickness and tightening bolt configuration to withstand all loadings.
- 1.8 The covers and all other carbon steel parts shall be cleaned, prepared and painted in accordance with Armstrong standards. For heat exchangers that are 56" (1270 mm) or taller, the moveable cover shall be provided with a roller assembly to easily move it during assembly and plate inspection.
- 1.9 The preferred connection arrangement is all four connections on the fixed front cover. Flow arrangement shall be vertical. A diagonal flow pattern is not acceptable. Connections shall be integral with the cover in either studded ANSI or NPT type to eliminate nozzle pipe loadings and leakage in the connection area.
- 2.0 The carrying bars for the plates and tightening bolts shall be stainless steel or zinc-coated carbon steel for rust prevention and ease of maintenance. Painted surfaces are not acceptable.
- 2.1 The frame and carrying bars shall be designed to allow for a plate expansion of at least 20% capacity while still providing maintenance space.
- 2.2 All units are to be provided with an aluminum safety shield for personal protection and to protect the plates and gaskets from the elements.
- 2.3 If ARI certification is required, the supplier and the equipment must be listed at www.ahridirectory.org for liquid to liquid heat exchangers.

Additional Armstrong Solutions



Design Envelope pump is designed to meet the needs of energy-efficient pumping systems in today's buildings. Traditional pumping systems, incorporating constant-speed pumps, waste energy through crude throttling valve flow control. Lifetime cost analysis shows that the capital cost of a constant-speed pump is typically only 5% of its lifetime cost.

TORONTO
23 Bertrand Avenue
Toronto, Ontario
Canada, M1L 2P3
T: 416-755-2291
F: 416-759-9101

BUFFALO
93 East Avenue
North Tonawanda, New York
U.S.A., 14120-6594
T: 716-693-8813
F: 716-693-8970

MANCHESTER
Wolverton Street
Manchester
United Kingdom, M11 2ET
T: +44 (0) 8444 145 145
F: +44 (0) 8444 145 146



© ARMSTRONG FLUID TECHNOLOGY 2016