

ARMSTRONG



Split Coupled Vertical In-Line Pumps

FILE NO:	43.10
DATE:	Mar. 01, 2010
SUPERSEDES:	43.10
DATE:	Nov. 14, 2008

Best Commercial HVAC Pump Design Available Since 1969

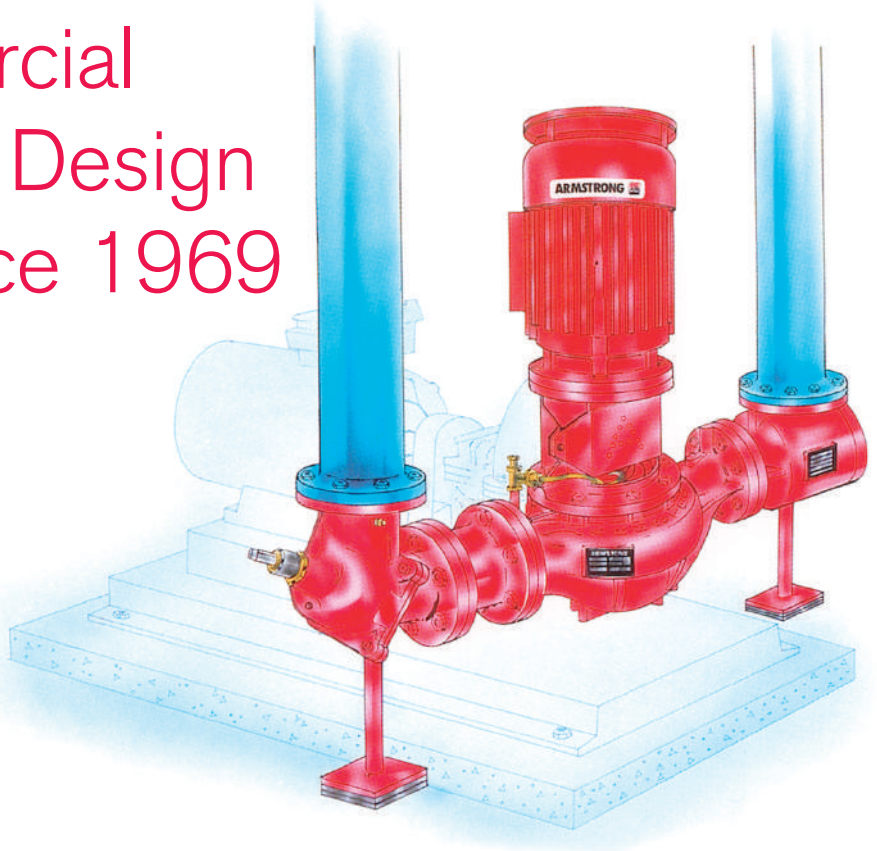

► Life Cycle Value at Every Turn:

INSTALLATION

Vertical In-Line pumps, being integral components of the pipework, eliminate need for inertia bases, inertia base springs, flexible pipe connectors, field grouting and alignment. Pipe hangers sized for the weight of pump, piping and fittings are the only supports required. Pipe stools, with vibration isolating pads, may be installed under each pipe leg.

SPACE SAVING

Greatest floor space savings result when Vertical In-Line pumps are installed with Armstrong Suction Guides and Flo-Trex valves. Equivalent base mounted, horizontal split case pumps may take 3 times more floor space.

MAINTENANCE

The mechanical seal is the critical service item in any pump. Removal of the Series 4300 split spacer coupling allows all mechanical seal components to be withdrawn for servicing, through the resulting space between pump and motor shafts, without disturbing other pump components or motor connection. Re-installing the rigid coupling brings the unit rotating assembly back to factory alignment specifications.

RELIABILITY

Dynamically balanced impeller and shaft assembly rotating vertically on the Series 4300 centerline translate to a quiet, long-lasting pump with minimum vibration, as static shaft deflection is eliminated. There are no pump bearings to service in the Vertical In-Line design. Series 4300 is a reliable, time-proven unit with less down time.

FLEXIBILITY

Small footprint, low installation costs, reliable and easy to maintain. These features, combined with flow range in excess of 30,000 USgpm (1,900 L/s), affirms the Series 4300 as the most flexible pump design available.

► Design Features

Split Coupled

- ① Industry standard motor designed for Vertical In-Line operation.
- ② Heavy cylindrical bracket with 360° register on each flange provides a rigid union of pump and motor.
- ③ Motor shaft run-out limited to 0.001" (0.025 mm) TIR (Total Indicator Reading).
- ④ Axially split, spacer type rigid coupling permits seal maintenance without disturbing pump or motor. Lightweight high tensile aluminum, precision bored and designed to reduce bearing load.
- ⑤ Shaft deflection at mechanical seal limited to 0.002" (0.05 mm) TIR.
- ⑥ Mechanical seal, accessible and easily replaceable (outside multi-spring balanced mechanical seal illustrated, see Page 5 for mechanical seal options).
- ⑦ Gland plate with flush connection ensures liquid at seal faces and positive venting of seal chamber.
- ⑧ Dynamically balanced impeller assures smooth vibration-free operation.
- ⑨ Radially split volute with equal suction and discharge flange sizes. Separate drilled and tapped openings for gauge, flush and drain connections.
- ⑩ Liberal inlet passageways and straightening vanes provide optimum suction performance and quiet operation.
- ⑪ Ribs cast integral with volute. Machined surface to accept floor support when specified.
- ⑫ Confined casing gasket to meet stringent industrial temperature and pressure applications.
- ⑬ Coupling guard fully encloses access openings (not shown).



Enwave District Cooling Facility, Toronto, Canada.



District Cooling Project, Phoenix, U.S.A.

Single Suction

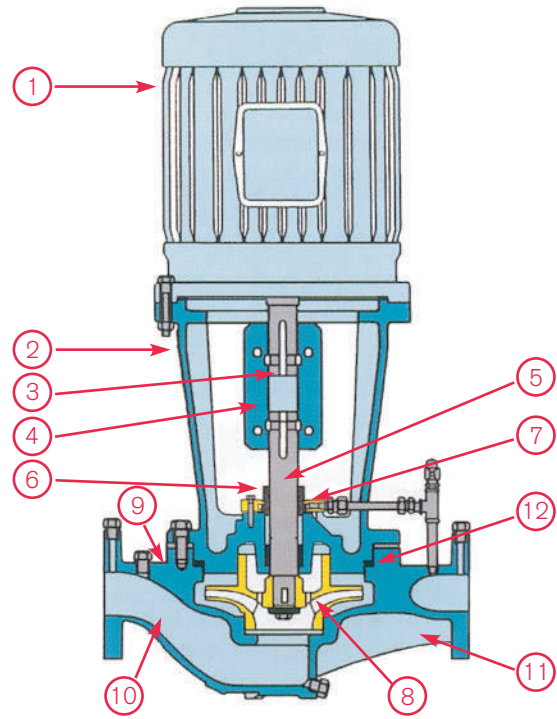

Double Suction

(12x12x13 Illustrated)

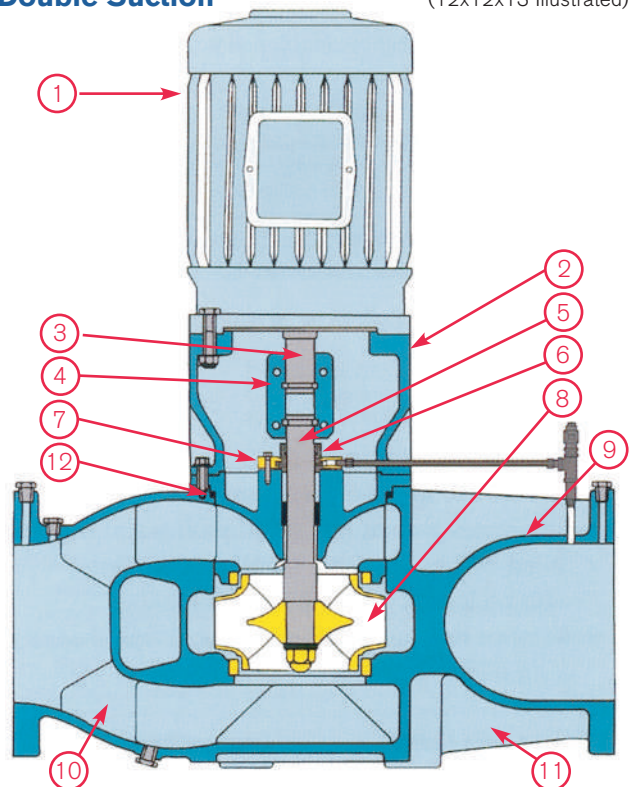

Split Coupled Vertical In-Line Pumps

► Materials of Construction

Series	ANSI Flange Rating psig	Construction	Volute	Gasket	Impeller	Capscrew	Washer	Acorn Nut	Adapter Cover	Adapter Bracket	Stuffing Box Cover	Motor Shaft	Pump Shaft	Coupling	Gland Plate
4300	125	BF	CI	F	BZ	S	SS-3	BR-2	CI	CI	CI	S	SS-6	AL	SS-5
		AI	CI	F	CI	S	SS-3	S	CI	CI	CI	S	SS-6	AL	SS-5
		AB	BZ	F	BZ	SS-5	SS-5	BR-2	BZ	CI	BZ	S	SS-6	AL	SS-5
	250	DI	DI	F	CI	S	SS-3	S	DI	DI	DI	S	SS-6	AL	SS-5
		DBF	DI	F	BZ	S	SS-3	BR-2	DI	DI	DI	S	SS-6	AL	SS-5

Material Construction Legend

AB - All Bronze	CI - Cast Iron ASTM A48 class 30	SS-2 - Stainless Steel ASTM F593
AI - All Iron	DI - Cast Ductile Iron ASTM A536 grade 65-45-12	Alloy group 2
BF - Iron Body, Bronze Fitted	F - Fiber	SS-3 - Stainless Steel ASTM A276 type 303
DI - Ductile Iron	N - Neoprene	SS-5 - Stainless Steel ASTM A276 type 316
DBF - Ductile Iron, Bronze Fitted	S - Steel	SS-6 - Stainless Steel ASTM A276 type 416
AL - High Tensile Aluminum Bar	BR-1 - Hard brass tubing ASTM B111	
BZ - Cast Bronze ASTM B584 grade C84400*	BR-2 - Brass Bar ASTM B16	

*Zero Lead Bronze is used for potable/drinking water applications.

► Pressure/Temperature Chart†

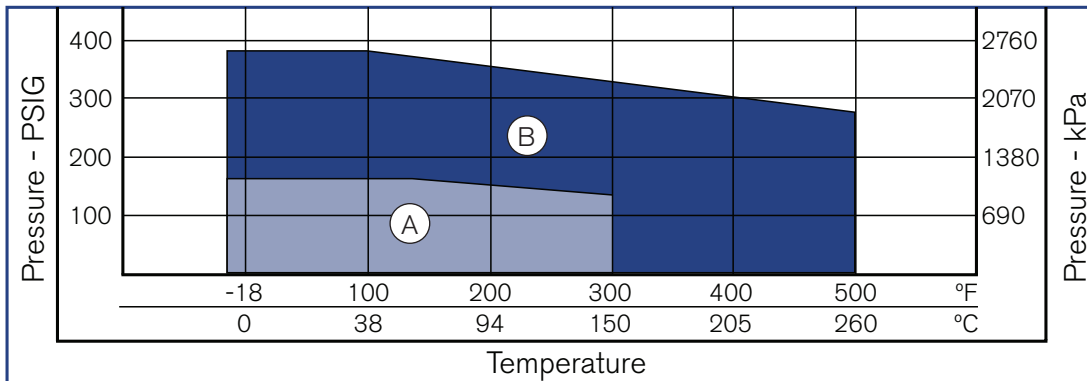

- (A) ANSI-125 Cast Iron
- (B) ANSI-250 Ductile Iron

†Refer to File No: 43.50 for mechanical seal pressure/temperature limitations.



Dr. Arnaldo Hospital for women, Sao Paulo, Brazil.



Canary Wharf Tower Building, London, England.

► Split Coupled

The axially split, spacer type rigid coupling permits seal maintenance without disturbing the pump or motor connections. The mechanical seal is accessible and easily replaced. (Outside multi-spring balanced mechanical seal is illustrated).



1) Split coupling with outside seal. Axially split coupling shown with coupling guard removed. Coupling bolts are still in place. Rotating element of seal is seen below the coupling, above gland plate.



2) Remove the coupling bolts. The coupling halves (with drive and annular positioning keys) are taken from motor and pump shafts. Loosen set screws on seal rotating element and slide from pump shaft. (For inside seal see step 3)



3) Disconnect seal flush line and remove gland plate bolts. The gland plate and seal seat may then be taken out between the space in the shafts. With inside seal the complete seal is removed following the gland plate.



4) New Seal may now be installed. Reverse the procedure: Install new seal, replace gland plate, replace coupling and restart pump. Rigid coupling retains factory alignment.

► Sealing Arrangements

Armstrong series 4300 split coupled Vertical In-Line pumps are available with two mechanical seal arrangements. Both can be removed easily and quickly for servicing without costly removal of the motor or pump from the piping. The high performance outside type mechanical seal combines the advantages of a multi-spring balanced seal with premium quality and is the easiest to remove. The inside type mechanical seal provides an economical alternative.

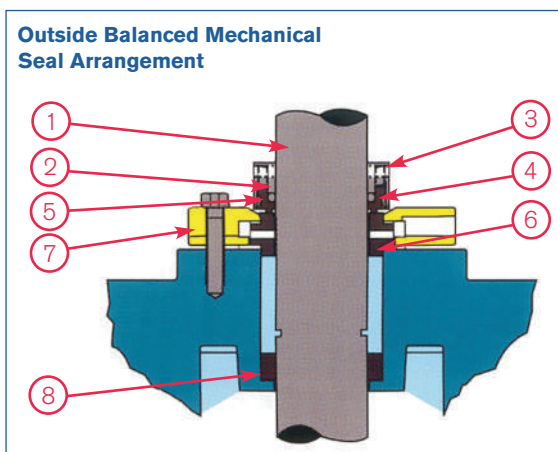

- ① Pump Shaft
- ② Rotating Hardware
- ③ Spring(s)
- ④ Secondary Seal
- ⑤ Rotating Face
- ⑥ Stationary Seat
- ⑦ Gland Plate
- ⑧ Throttle Bushing

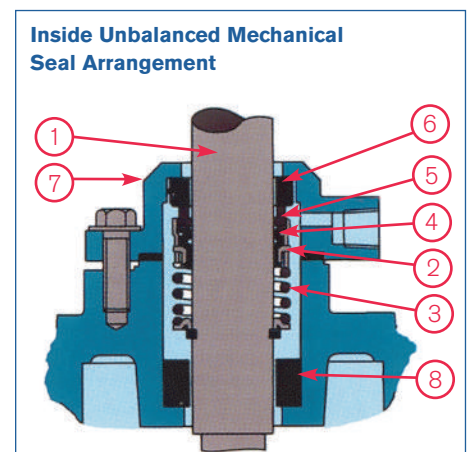

Inside Unbalanced Mechanical Seal Arrangement

► Typical Specifications

1. Provide Vertical In-Line (VIL) pumps, single stage, single or double suction type, with pump characteristics which provide rising heads to shut off. Refer to pump schedule for pump flows and heads and motor speed, enclosure, efficiency and power requirements and other system conditions. Provide Armstrong Series 4300 split-coupled type VIL units, with rigid spacer type coupling.
2. Pump Construction: Pump Casing - Cast Iron with ANSI-125/PN16 flanges for working pressure to 175 psig (12 bar) at 150°F (65°C) and Ductile Iron with ANSI-250/PN25 flanges for working pressures to 375 psig (25 bar) at 150°F (65°C). Suction and discharge connections shall be flanged and the same size and shall be drilled and tapped for seal flush and gauge connections.
3. Impeller - Bronze, fully enclosed type. Dynamically balanced. Two-plane balancing is required where installed impeller diameter is less than 6 times the impeller width.
4. Shaft - Provide Stainless Steel pump shaft.
5. Coupling - Rigid spacer type of high tensile aluminum alloy. Coupling to be designed to be easily removed on site to reveal a space between the pump and motor shafts sufficient to remove all mechanical seal components for servicing and to be replaced without disturbing the pump or motor.
6. Mechanical Seals - Shall be Stainless Steel multi-spring outside balanced type with Viton secondary seal, carbon rotating face and silicon carbide stationary seat. Provide 316 stainless steel gland plate. Provide factory installed flush line with manual vent.
7. All split coupled pumps shall be provided with a lower seal chamber throttle bushing to ensure seals maintain positively cooling and lubrication.
8. Seal flush line accessories, if required to improve seal chamber cleanliness: Supply in the flush line to the mechanical seal a 50 micron cartridge filter and sight flow indicator, to suit the working pressure encountered.
9. Filters shall be changed, by the installing contractor, after system is flushed and on a regular basis until turned over to the owner.
10. Alternately, a maintenance-free accessory needing pump differential pressures exceeding 70 ft/30 psig/200 kPa for effective operation: Supply in the flush line to the mechanical seal a maintenance-free sediment separator, with sight flow indicator.

Other Armstrong Products

For even greater space savings, ease of installation and flexibility of use:

Specify Armstrong **dualARM** Vertical In-Line pump.

- Two (2) Armstrong time proven Vertical In-Line pumps in one (1) casing.
- Eliminates a complete set of piping and fittings.
- Stand-by or two pump parallel operation with no loss of single pump efficiency.
- Remove one pump for repair while the second pump continues to operate.

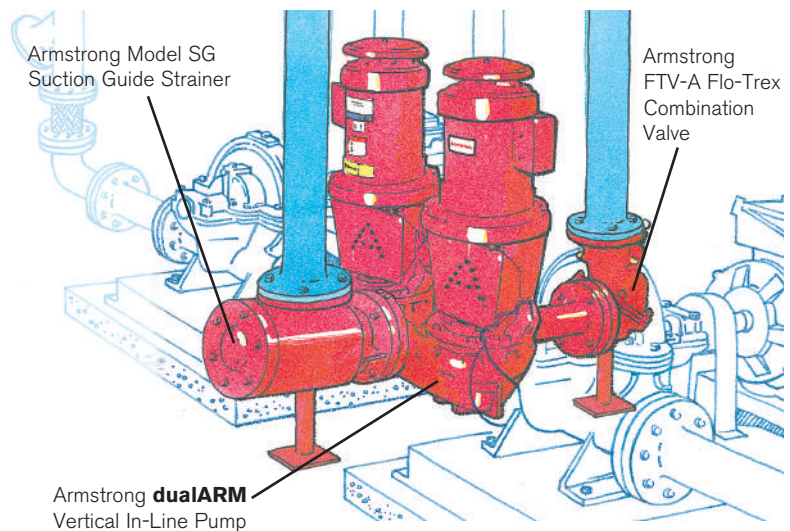

EXPERIENCE BUILDING...

S. A. Armstrong Limited
23 Bertrand Avenue
Toronto, Ontario
Canada, M1L 2P3
T: (416) 755-2291
F (Main): (416) 759-9101

Armstrong Pumps Inc.
93 East Avenue
North Tonawanda, New York
U.S.A., 14120-6594
T: (716) 693-8813
F: (716) 693-8970

Armstrong Integrated Limited
Wenlock Way
Manchester
United Kingdom, M12 5JL
T: +44 (0) 8444 145 145
F: +44 (0) 8444 145 146

ARMSTRONG 

© S.A. Armstrong Limited 2010

For Armstrong locations worldwide, please visit www.armstrongintegrated.com